



**EIGHTH EDITION**

**NORTH AMERICAN  
SADDLE MULE ASSOCIATION**

**2011-2012**

**Official Handbook  
BY LAWS  
RULES & REGULATIONS**

*This Rule Book Supersedes All Previous Rule Books*



# TABLE OF CONTENTS

FORWARD.....	3
STATEMENT OF POSITION.....	4
DONKEY .....	5
CHARTER MEMBERS .....	6
LIFETIME ACHIEVEMENT .....	7
NASMA YOUTH .....	9
CORPORATION BY-LAWS.....	10
ENGLISH .....	75
DRIVING .....	81
WESTERN.....	90
CATTLE CLASSES.....	114
GYMKHANA EVENTS .....	125
SHOWMANSHIP .....	142
MULEMANSHIP .....	142
SPECIALTY CLASSES .....	146
APPENDIX .....	150
INDEX.....	162

The North American Saddle Mule Association  
[www.nasma.net](http://www.nasma.net)

*New rules are in red bold italics*

*This Rule Book Supersedes All Previous Rule Books*

© 2011 by The North American Saddle Mule Association

# NASMA

## OFFICERS & BOARD OF DIRECTORS

### *Officers*

PRESIDENT: ...Tom Cochran, Chapel Hill NC  
VICE PRESIDENT...Peggy Hamilton. Willow Hill IL  
EXECUTIVE SECRETARY...Stacy Golian, New London MO  
TREASURER.....Terri C. Barfield, Greensboro NC  
REGISTRAR.....Deby Cochran, Chapel Hill NC

### *Executive Committee*

PRESIDENT..... Tom Cochran, Chapel Hill NC  
PRESIDENT ELECT.....Terri Wagner, Keenesburg CO  
Larry Cox. Monroe LA  
Peggy Hamilton. Willow Hill IL  
Shannon Ambrosio, Brighton CO

### *Directors Emeritus*

Bill Duncan

### *Directors At Large*

Greg Sefton, FL  
Jim Adkins, CO  
Loyd Hawley, AR  
Tim Doud, WY  
Karl Schneider, TN

### *Directors*

Joyce Stratton	Scio OR
Margo Hepner-Hart	Hillsboro OR
Connie Lara	Flagstaff AZ
Crystal Ward	Placerville CA
Nancy Luck	San Jose CA
Kathryn Herrin	Canon City CO
Shannon Ambrosio	Brighton CO
Terri Wagner	Keenesburg CO
Jay Jaxheimer	Wellborn TX
Stephen Jardot	Bartlesville OK
Sue King	Boyd TX
Ken Colbert	Steeleville MO
Mel Wilson	Iberia MO
Peggy Hamilton	Willow Hill IL
Doug Waugh	Mays Lick KY
Larry Cox	Monroe LA
Bonnie Garey	Eden NY
Donna Wilburn	Glen Dale WV
Herb Heroy	Standardville VA
David McDonald	Mt Pleasant NC
Diane Swift	New Hill NC
Terri C. Barfield	Greensboro NC



## FORWARD

The North American Saddle Mule Association was formed in 1994 to collect record and preserve the records of the Saddle Mule. The Saddle Mule, defined as any horse/donkey hybrid, is an animal resulting from the breeding of either a male donkey jack to a saddle horse type mare horse or a saddle type horse stallion to a donkey jennet and used for work and pleasure under saddle and in light harness. The growth of the Saddle Mule in numbers and public acceptance is an indication of the fulfillment of this need. The Association also serves as an information center for its members and the general public on matters pertaining to shows, contests and projects designed to improve the Saddle Mule and aid the industry.

Halter shows and performance contests give breeders and exhibitors opportunities to compete for awards. The public events also demonstrate progress in breeding for type, quality and the ability to perform.

This edition of the NASMA Official Rule Book contains the governing rules pertaining to shows, in addition to the NASMA Corporate by laws.

While the emphasis of NASMA is the saddle mule, this does not mean that donkeys are to be excluded from NASMA events. NASMA takes a position that encourages clubs and organizations to hold donkey classes, both Halter and Performance, simultaneously with Saddle Mule classes. NASMA does address the issue of donkeys' humane treatment at any NASMA event, their inclusion in Specialty Breeding classes and outlines those modifications of any class listed in this rule book to meet the unique exhibition requirements of donkeys. NASMA supports the use and promotion of donkeys as excellent saddle and harness animals and it gratefully acknowledges the contribution the donkey has made to the Saddle Mule.

In addition, NASMA encourages any local club or organization that has sufficient entries for the "exotic" crosses to provide an opportunity for those animals to be exhibited. Hybrids of other than a horse/donkey cross may be present in numbers to justify their exhibition in their own classes in Halter and Performance and NASMA advocates the inclusion of such separate classes for the "exotic" crosses.

Membership is open to individuals, local clubs, organizations, corporations and partnerships. Membership in NASMA does not conflict with local club membership. Local clubs are free to adopt NASMA rules and have NASMA sanction their shows if their members would like their points to count toward awards.



## **STATEMENT OF POSITION**

The North American Saddle Mule Association's objectives are to preserve the records of the exhibition of the Saddle Mule in all equestrian disciplines in which it is used, while maintaining the integrity of the Saddle Mule. Further, it encourages Saddle Mule ownership and participation. It advocates the promotion of the Saddle Mule for both pleasure and competition. NASMA actively protects the Saddle Mule by establishing and strictly enforcing rules which govern every NASMA approved event in order to reflect the natural ability of the animal. To that end, NASMA is committed to the following beliefs:

- ▶ Every Saddle Mule shall, at all times be treated humanely and with dignity, respect and compassion.
- ▶ Stringent rules established and enforced by NASMA demand that breeders, owners, trainers and exhibitors are continually responsible for the well being and humane treatment of any Saddle Mule entrusted in their care.
- ▶ Above all, the Saddle Mule's welfare is paramount to other considerations and the continued development of procedures which ensure humane treatment of the breed and fair competition supercedes all other considerations.
- ▶ NASMA will develop and review adequate and fair rules governing competitions and to enforce them for the common benefit.
- ▶ NASMA will encourage and assist all those involved in the breeding for, exhibition and promotion of the Saddle Mule in the continued improvement of the Saddle Mule in regard to its performance and development as a desirable saddle and harness animal.

# The American Donkey & Mule Society Statement of Position



The American Donkey and Mule Society endorses the effort of the North American Saddle Mule Association to organize and administer a national governing body for the standardization of rules for mule and donkey competitions and the training and carding of judges for such competitions. It is beyond the scope of duties of the American Donkey and Mule Society to establish and maintain the framework for competitions and judges nationwide and we have never wished to attempt this project. The American Donkey and Mule Society is primarily a registry and education and service body and it desires to work with NASMA to facilitate standardization of competition in North America and to encourage registration of competing mules and donkeys. It is hoped that this effort will succeed in giving both competitors and judges consistent, fair and equitable competition criteria in all parts of the country.

The American Donkey and Mule Society endorses the North American Saddle Mule Association's rule book and will suggest it as our guideline for show competition for larger donkeys and saddle mules. We will also approve judges who are officially approved by NASMA and will sanction any shows which are also sanctioned by NASMA.

October 1, 1997

*Paul & Betsy Hutchins, President*  
*Betsy Hutchins, Secretary*

Paul & Betsy Hutchins  
ADMS



## CHARTER MEMBERS

The following families have made a substantial financial commitment to the development of this association. Their charter memberships provided the initial funds with which to underwrite the formation NASMA. Without their commitment to saddle mules and the saddle mule industry, NASMA would not be a reality. Their foresight and pledge of confidence is greatly appreciated by the association.

Allen & Elaine Case, Oregon  
Bill & Jane Moore, Tennessee  
Bob & Mary Mischka, Wisconsin  
Diann & Bob Walker, Texas  
Dixie Musick, Texas  
Greg & Liz Sefton, Florida  
Herb & Beverly Heroy, Florida  
Jim & Sue King-Joling, Texas  
Jim Adkins & Lynn Eustance, Colorado  
Joyce & John Stratton, Oregon  
Judy Rose, California  
Loyd & Sarah Hawley, Arkansas  
Nick & Lynne York, Colorado  
Tex Low, Texas  
Tom & Glenda Fagg, Texas  
Warren Bagley, Tennessee

### **Presidential Charter Memberships In Recognition of Service to the Association**

Bill Duncan, Kansas  
Tim Doud, Wyoming  
Cheryl Metheny, Oklahoma  
Tom Cochran, North Carolina



## **LIFETIME ACHIEVEMENT AWARD RECIPIENTS**

The North American Saddle Mule Association recognizes the following individuals for their outstanding dedication to the promotion of the saddle mule and their commitment of their time and talents in achieving NASMA goals.

**Paul and Betsy Hutchins, Texas**  
**Dr. Robert Miller DVM, California**  
**Dr. Tex Taylor, Texas**  
**Meredith Shultz Hodges, Colorado**  
**Sue Cole, Missouri**  
**Ron Clayton, Arizona**  
**Bonnie Shields, Sandpoint, Idaho**  
**Ken Colbert, Missouri**  
**Karl Schneider**  
**Sue King, Texas**  
**Lori Montgomery, Kentucky**



## **VERSATILITY TRAIL PROGRAM**

NASMA believes the recreational activity of riding or driving the Saddle Mule on the trail is just as important as contests and events are in educating the public about the benefits of Saddle Mule ownership. Whether you are involved in recreational, endurance or competitive trail activities, NASMA would like to recognize your pastime with an awards program to acknowledge your contribution in bringing the Saddle Mule to the forefront as the new equine of choice in the 21<sup>st</sup> century.

When you enroll in the Versatility Trail Program, you will receive the official NASMA VTP patch to wear and the official log sheet on which you keep track of the hours you spend riding or driving a Saddle Mule on the trail. You set your own pace and there is no time limit for completion of any level of participation. NASMA would like to challenge You to do your personal best, not compete with other riders.

Individuals must maintain current NASMA membership. A one time enrollment fee of \$20 must accompany the application to the VTP Program. NASMA membership may be obtained upon application providing the proper fee is enclosed.

Failure to maintain continuous NASMA membership shall result in forfeiture of hours accrued.

### **VTP ACHIEVEMENT LEVELS**

**50 hours**  
**100 hours**  
**250 hours**  
**500 hours**  
**750 hours**  
**1,000 hours**  
**2,000 hours**



NASMA reserves the right to change terms and/or conditions of these rules as well as awards.



## **NASMA YOUTH**

The North American Saddle Mule Association Youth was established by the Board of Directors in 1996 to provide an organization for youth in the Saddle Mule industry to have the opportunity to earn recognition for their efforts on behalf of the Saddle Mule, to provide financial assistance for the pursuit of higher education and to provide an atmosphere in which youth can learn positive values through trail riding, family activities and competition.

Youth is defined anyone eighteen years and younger. Membership in NASMA Youth is available for \$10 per year and all youth are encouraged to participate in all youth programs.

Each year, two \$500 dollar scholar ships are awarded to NASMA seniors in high school who have met certain criteria and will be continuing their education.

NASMA believes that NASMA Youth are the future of the Association and will continue our efforts to promote protect and enjoy the Saddle Mule in the future.

THE NORTH AMERICAN  
SADDLE MULE ASSOCIATION

**Corporation By-Laws**

*Approved by the Board of Directors on August 3, 2008*

**ARTICLE I**

**TITLE, OBJECTIVES, LOCATION, CORPORATE SEAL**

**Section 1. Title:** This Association shall be known as NASMA doing business as The North American Saddle Mule Association, and shall at all times be operated and conducted as a nonprofit association in accordance with the laws of the State of Texas providing for such organizations and by which it shall acquire all such rights as granted to associations of this kind.

**Section 2. Objectives:** The purpose of this Association shall be to collect record and preserve all available information pertaining to Saddle Mules and their donkey ancestors. The Saddle Mule, defined as any horse/donkey hybrid, is an animal resulting from the breeding of either a male donkey jack to a saddle horse type mare or a saddle horse type stallion to a donkey jennet. In addition, NASMA is to encourage and regulate any and all exhibitions approved by the Association. NASMA endeavors to promote the Saddle Mule for both pleasure and competition.

**Section 3. Place of Business** The principle place of business shall designated by the Board of Directors, but its members or officers may be residents of any state, territory or country, and business may be carried on at any place convenient to such members or officials, as may be participating.

**Section 4. Corporate Seal** The Corporate Seal of the Association shall be in the charge of the Executive Secretary and shall be in the form impress hereon immediately below.



**ARTICLE II**

**MEMBERS**

**Section 1. Members of the Association** shall be admitted, retained and expelled in accordance with such rules and regulations outlined in General Rules #104. In all matters governed by the vote of the members, each membership in good standing shall be entitled to one vote. NASMA Youth members are entitled to vote only in the NASMA Youth Organization.

**Section 2. The Regular Annual Meeting** of the members shall be held at such time and place as may be determined by resolution of the Board of Directors for the purpose of electing officers, installation of newly elected Directors and for the transaction of

such other business as may be brought before the meeting. Notification of the Meeting and the Agenda of Meeting will be made in the mule industry publications, the Official NASMA website and e-mail. This is the only notification required. Members who desire to stay informed of the NASMA meetings and activities have an affirmative duty to subscribe to one of the Mule publications, request notification by e-mail and refer to Official NASMA website. Notice shall be deemed to be delivered with the publication containing such notice shall be deposited in the United States mail addressed to the member at his address as it appears on the records of the Association, with postage prepaid, with the publication containing such notice is added to the Official NASMA website, or send via e-mail.

**Section 3. Special Meetings** of the members may be held at such time and place as may be designated in the notice, whenever called in writing by the direction of the President or by a majority of the Board of Directors, or by individual copies or facsimile of the notice signed by not less than twenty percent of the members in good standing. Notice of each special meeting indicating the Agenda thereof shall be given in the same manner as provided with respect to notice of Annual Meetings.

**Section 4.** At any meeting of the members held in accordance with the foregoing provisions as to notice and Agenda, the members attending such meeting shall constitute a quorum for all purposes unless the representation of a larger number should be required by laws under which NASMA is Chartered. To exercise voting privileges, a member must be physically present at the meeting, which privilege cannot be delegated or proxy.

**Section 5.** Any officer of the Association may call the meeting of the members to order and may act as Acting Chairman of such meeting, precedence being given as follows: President, Vice President In the absence of all such officers, members present may elect a chairman.

The Executive Secretary of the Association shall act as secretary of the Association of all meetings of the members, but in his/her absence the Acting Chairperson may appoint any person to act as Acting Secretary for the meeting.

**Section 6.** Whenever in these By-Laws the term member or members shall be used, unless otherwise specified, it shall mean a member(s) in good standing having the right to vote.

## ARTICLE III

### DIRECTORS

**Section 1.** The business and property of the Association shall be managed and controlled by the Board of Directors, and an Executive Committee hereinafter created and empowered.

The By-Laws and rules affecting the exhibition of Saddle Mules and the Awards Program shall be subject to change only by the Board of Directors.

**Election of Directors** The Association shall have 24 elected directors, 3 from each of the designated zones 1 thru 8.

**A.** Each Director elected to represent a geographical zone shall be domiciled in the zone which he represents by actual residence therein, having the intent to make it his permanent home. To be eligible for election to and serve on the Board of Directors, an individual must be a member in good standing of the Association for one year prior to the nomination.

**B.** Each director is elected for a three year term. Terms are staggered so that only one-third ( $\frac{1}{3}$ ) of the directors are replaced each year.

**C.** Should the need arise for a different allocation of representatives per zone, reallocations will be made at the annual meeting by the Board of Directors vote.

D. Each membership in good standing in the year of the Director Nomination shall receive a ballot for their representative zone and shall be entitled to one vote to nominate someone from their zone for each vacancy to be filled and one vote in the subsequent election of Directors based on those nominations. .



E. The term "**representative zone**" shall be defined as:

**Zone 1:** Alaska, Idaho, Montana, Oregon & Washington

**Zone 2:** Arizona, California, Hawaii, Nevada, & Utah

**Zone 3:** Colorado, Kansas, Nebraska, North Dakota, South Dakota & Wyoming

**Zone 4:** New Mexico, Oklahoma, & Texas

**Zone 5:** Illinois, Indiana, Iowa, Michigan, Minnesota, Missouri, Ohio and Wisconsin

**Zone 6:** Alabama, Arkansas, Kentucky, Louisiana, Mississippi and Tennessee

**Zone 7:** Connecticut, Delaware, District of Columbia, Maine, Maryland, Massachusetts, New Hampshire, New Jersey, New York, Pennsylvania, Rhode Island, Vermont, Virginia, and West Virginia.

**Zone 8:** Florida, Georgia, North Carolina and South Carolina

**Zone 9:** Canada

F. **National Directors Nominating Committee** shall be appointed by the President and publicly announced by February 1 of each election year. This Committee will conduct the nomination procedures and elections for filling vacancies

1. **Nominations** from Regional clubs In addition, an individual may nominate themselves upon submission of the signatures of five NASMA current members in good standing evidencing endorsement of the nominee. Nomination forms will be sent upon request.

2. To be eligible, each individual nominated shall be a bona fide resident of his representative zone and a current NASMA member in good standing.

3. There may be only one director/alternate elected per membership.

4. The Regional Club recommendations and individual nominations for directors must be forwarded to the National

Director's Nominating Committee and bear postmark date, Official NASMA Website submission date or e-mail date no later than February 15, of the election year.

5. The Nominating Committee shall prepare a ballot for each representative zone its own nominations and individual nominations accompanied by the appropriate five member's signatures. This is the only nomination procedure for the election of National Directors. Nominations from the floor are not allowed. Any vacancies occurring after the Annual Meeting and before the President's announcement National Directors Committee for the next year will be filled by the President.

6. After February 15 of the elections year, the National Directors Nominating Committee will accept Director Nominations submitted on the Official NASMA Website and mail a nomination ballot of each Representative Zone to all of the members of such Representative Zone to be returned via mail or submitted on the Official NASMA Website.

7. The National Directors Committee will obtain written verification of acceptance of nomination from the nominee by either mail or e-mail before that nominee's name will be put on the ballot.

8. **Results of elections** shall be furnished to each member no later than thirty (30) days after election. Notification can be in writing, e-mail or publication on the Official NASMA Website The written notification may be made in the regular Association newsletter. Introduction and installation of newly elected Directors will occur at the commencement of the next Annual Meeting.

**G.** The nominees receiving the highest number of votes on the ballot will be named director(s). The individual receiving the next highest number of votes will be named Alternate. When there is only one nominee for the National Director, the President may appoint an alternate for that representative zone

**H.** In addition to the directors so elected, all Past Presidents, the President, and the President-Elect created on the Board of Directors when the President and the President Elect become Directors-at-Large, will be filled by first, the Alternate who is the nominee receiving the next highest votes (Section H.) and then, if there is no Alternate, by appointment by the President.

**I.** Any Director-at-Large who has not been marked present at minimum of at least one of four consecutive Board of Director Meetings abiding by the quorum requirement of 13, including Annual Meeting Board and those before the next Annual Board Meeting would be deleted from the Board of Directors and would become a Director Emeritus.

**J.** The Board of Directors for the coming year must be determined by June 1 of the election year. Directors shall be introduced and installed in office upon the start of the Annual Meeting Election and installation of officers will occur as the first item in New Business at the Annual Meeting.

**Section 2. In case of any vacancy** in the Board of Directors by death, resignation or any other cause, after the election, the President shall appoint a successor for the same zone in which the vacancy occurs to serve the remainder of the unexpired term.

**Section 3.** Any Officer or Director of this Association, unless excused by the President, Any Director-at-Large who has not been marked present at minimum of at least one of four consecutive Board of Director Meetings abiding by the quorum requirement of 13, including Annual Meeting Board and those before the next Annual Board Meeting would be deleted from the Board of Directors. Said Officer Director shall have the right of appeal before the President of the Association. Upon receiving a written request to be reinstated and hearing the appeal, the President may reinstate the Officer.

**Section 4.** The regular **Annual Meeting** of the Board of Directors shall be held immediately following the Annual Members' Meeting, and no notice shall be required for any such regular meeting of the Board of Directors. The Board of Directors, by rule, may provide for other Regular Meetings at stated times and places, after the initial announcement of which, no notice shall be required. Absentee or vote by proxy is not allowed in any meeting of the Board of Directors. Voting by attendance by video or speaker phone is allowed.

**Section 5. Special Meetings of the Board of Directors** shall be held whenever called by the direction of the President, or by two-thirds of the directors in office at the time.

The Executive Secretary shall provide notice of each Special Meeting by mailing, telephoning, or e-mail the same to each director at least fifteen (15) days before such meeting, but such notice may be waived in writing by any director. Only business indicated in the notice thereof may be transacted at a special meeting.

Any business may be transacted at any meeting at which every director may be present, even if the meeting was called without any notice.

**Section 6. Thirteen (13) elected (excluding past presidents) Directors shall constitute a quorum** for the transaction of business, but if at any meeting of the Board of Directors, consisting of less than a thirteen elected Directors present, a majority of those present may adjourn the meeting from time to time until a quorum shall be present. No absentee Director can be removed from office in order to create a vacancy to be filled with a member in attendance in order to establish the required the quorum.

**Section 7.** At the Regular Annual Meetings of the Board of Directors, the Board shall proceed to the election of officers of the association at the introduction of New Business on the agenda of the meeting.

**Section 8.** Only the Board of Directors shall have the power and authority to make, amend, repeal and enforce such rules and regulations, not contrary to law of the Certificate of Incorporation or these By-Laws, as they may deem expedient concerning the conduct, management and activities of the Association, the admission, classification, suspension and expulsion of members, removal of officers, the rules and regulations governing the procedure of such suspension and expulsion and removal, the fixing and collecting of dues and fees, regulations regarding stud book listings, registrations, awarding of championships, the conducting of shows, contest, exhibitions, races, sales and social functions and all other details relating to the general purposes of the Association.

**Section 9.** All actions of the Board of Directors are subject to revision or amendment by the members at any Special or Regular Meeting of the membership provided that written notice of any intention to revise or amend has been published at least thirty (30) days in advance of that meeting by publication in the Mule Magazines, publication on the Official NASMA Website, e-mail or mail.

**Section 10.** The Board of Directors, from time to time, may create and empower other committees, general and special.

**Section 11.** No Director of the NASMA shall be liable to the NASMA or its members for monetary damages for an act or omission in such director's capacity as a director of the NASMA,

**A.** except that these Articles shall not eliminate or limit liability of a director of NASMA for:

- 1.** An act or omission for which the liability of a director is expressly provided for by statute.
- 2.** An act or omission not in good faith or that involves intentional misconduct or a knowing violation of the law.

3. A transaction from which a director received an improper benefit, whether or not the benefit resulted from an action taken within the scope of the director's office; or

4. An act or omission for which the liability of a director is expressly provided for by statute.

**B.** Any repeal or amendment of this Article by the members of the NASMA shall be prospective only, and shall not adversely affect any limitation on the personal liability of a director of the NASMA existing at the time of such repeal or amendment. Anything herein to the contrary notwithstanding, if the Texas Miscellaneous Corporation Laws Act is amended after approval by the members of this Article to authorize corporate action further eliminating or limiting the personal liability of directors, then the liability of a director of the NASMA shall be eliminated or limited to the fullest extent permitted by the Texas Miscellaneous Corporation Laws Act, as so amended from time to time.

## ARTICLE IV

### EXECUTIVE COMMITTEE

**Section 1.** There is hereby created an Executive Committee consisting of the President, President-Elect, The Immediate Past President and three additional members. These officers and additional members shall be elected from the Board of Directors at the annual meeting of the Board, each for a term of one year and until the selection and qualification of his successor.

The President shall appoint and publicly announce a Nominating Committee for National Officers and the Executive Committee by February 1 of the election year. Officer recommendations of the National Director Nominating Committee shall be published at least thirty (30) days prior to the Annual Meeting on the Official NASMA Website, e-mail or mail.

The President is hereby empowered to appoint five advisors without voting power, to the Executive Committee. Any member of the NASMA in good standing shall be eligible for selection as advisor with only one individual per membership being eligible.

**Section 2.** No officer or member of the Executive Committee may serve on the Executive Board in excess of five consecutive years.

**Section 3.** The President shall fill all vacancies the Executive Committee occurring between annual meetings of the Association.

**Section 4.** The Executive Committee shall meet whenever and wherever called by direction of the President or three members of the Executive Committee acting jointly, of which each meeting the Executive Secretary shall give ten (10) days written notice by mail or e-mail, but such notice may be waived in writing by any member. Absentee or vote by proxy is not allowed in any meeting of the Executive Committee. Voting by attendance by video or speaker phone is allowed

**Section 5.** The Executive Committee may act without conversing in meeting by written resolution signed by all members thereof and duly entered in the Associations records. At all meetings of the Executive Committee, four members shall constitute a quorum.

**Section 6.** All actions of the Executive Committee with the exception of disciplinary actions resulting from hearings, are subject to ratification, revision or amendment by the directors at any regular or special meeting of Directors.

**Section 7.** It shall be the responsibility of the Executive Committee to direct the handling of questionable mule registrations applications, to direct all other Association business matters, to furnish liaison members to all Standing Committees, to report to the Board of Directors at its Annual Meetings, to interview persons

for the position of Executive Secretary and appoint a person as Executive Secretary.

**Section 8.** The Executive Committee shall be responsible for reviewing, forwarding to the appropriate committee and presenting to the Board of Directors for approval all questions or ambiguities that may arise in connection with the meaning, intent or purpose of any by-law, rule, regulation or other NASMA document.

## ARTICLE V

### OFFICERS AND DUTIES

**Section 1. Officers:** The Officers of the Association shall be the President, President Elect, Vice President, Executive Secretary and Treasurer. And such other officers as may be authorized from time to time by the Board of Directors.

**Section 2. Eligibility:** Only members of the Board of Directors shall be eligible to serve as officers of the Association. The President Elect must be elected from the current Executive Committee. The Executive Secretary should not be a member of the Board of Directors.

**Section 3. Election:** The officers of the Association shall be elected by majority vote by the Board of Directors at the Annual Meeting from the nominations of the National Directors Nomination Committee. No nominations will be taken from the floor.

**Section 4. Term:** Unless otherwise specified in any employment contract approved by the Board of Directors, the officers of the Association shall hold office for a period of one (1) year and until their successors are elected and installed. The elected Officer shall begin his/her term immediately following the election to be held as the first item of New Business on the agenda of the Annual Meeting and continue until the installation of new Officers at the following year's Annual Meeting. Officers may be nominated by the National Directors Nominating Committee and shall be published at least thirty (30) days prior to the Annual Meeting on the Official NASMA Website, e-mail or mail and be re-elected for consecutive terms.

**Section 5. Duties:** Any Officer who receives remuneration in the form of a salary and/or benefits for duties performed while serving in the capacity of an Officer of NASMA, must enter into a written and signed employment contract approved by the Board of Directors,

**A. President** The President shall be the Chief Executive Officer of the Association and shall preside at all meetings of the Board of Directors. He/she shall see that the By-Laws, rules and regulations of the Association are enforced and shall perform all other duties that may be prescribed from time to time by the Board of Directors. He/she shall be an ex-officio member of all committees.

**B. President-Elect** In the absence of the President, the President-Elect shall have the power and shall perform the duties of the President and such other duties as may be prescribed by the Board of Directors. Upon the expiration of the President's term of office, the President-Elect shall automatically become President. The President-Elect will serve as the Chairman of the By-Laws Committee.

**C. Vice President** In the Absence of the President and the President-Elect the Vice President shall have the power and shall perform the duties of the President and such other duties as may be prescribed by the Board of Directors.

**D. Executive Secretary** The Executive Secretary shall be responsible for seeing that the minutes of all Membership and Directors meetings are kept; for the safekeeping of all documents and records of the Association. He/she shall be

responsible for seeing that all money due the Association is collected. He/she shall be an ex-officio Member Secretary of all Committees appointed by the President or Board of Directors. He/she shall make a detailed report of his/her office to the Board of Directors when demanded and to all Annual Membership meetings, and shall perform such other duties as may be prescribed by the Board of Directors that do not conflict with Texas Not For Profit Corporation law

**E. Treasurer** The Treasurer shall receive the money turned over to him/her by the other officers and all other money. He/she shall disburse the money of the Association; however, only upon itemized demands and upon the order of the Board of Directors. He/she shall account for all the same by itemized statements in detail to each annual meeting of the members and the Board of Directors when demanded. He/she will submit to an independent audit yearly to be presented at the Annual Meeting. Also, he/she shall cause to be submitted to the Executive Committee, at the first meeting following the annual meeting of the members, a detailed budget of the proposed and anticipated expenditures for the forthcoming fiscal year of the Association. Upon approval of this said budget, or its modification, it becomes binding upon the officers of the Association, and cannot be exceeded in the total amount set forth by more than ten percent without a majority vote of the Executive Committee.

**Section 6.** The written contracts of the Association shall be executed on behalf of the Association by the President or President-Elect, approved by the Board of Directors and attested by the Executive Secretary and the corporate seal.

**Section 7. Vacancies:** All vacancies of the Officers of the Association shall be filled by Board of Directors based on the recommendations of the President announced 15 days in advance on the Official NASMA Website, mail or e-mail. The Appointee must fulfill all eligibility requirements for the position and will serve for the unexpired term and until the election and installation of their duly qualified successors.

**Section 8. Auditing Accounts:** This Association shall conduct its affairs on a calendar year basis, same to begin January 1 and end on December 31.

**Section 9. Surety Bonds** and all other officers or employees of the Association who may handle any funds of the Association shall give a surety bond to be furnished at the expense of the Association for the faithful discharge of his or her duties if so required by the Executive Committee.

## ARTICLE VI

### AMENDMENTS

**Section 1. Amendments to these By-Laws** may be made at any subsequent meeting held in accordance with these By-Laws by a majority of the Board of Directors present when the Amendment has been presented to the Membership at least two (2) weeks prior to said meeting held by this Association and no proxy or absentee vote will be take. Notice to membership shall be by mail and publication on Official NASMA Website.

**Section 2.** The Board of Directors shall have the power to make, amend, and repeal the By-Laws of the Association by vote of the majority of the Directors at any Regular or Special Meeting of the Board, subject to the right of the members to rescind or amend any such By-Laws in the same manner as provided in Section 10, Article III, for the Revision or Amendment of Rules and Regulations.

**Section 3.** To be eligible for consideration by the Board of Directors, a proposed amendment to NASMA by-laws shall be

filed in writing in the office of the President Elect at least 60 days prior to the meeting of the Board of Directors at which time the proposed amendment is to be considered. The proposed draft shall be promptly sent by the President Elect to each individual eligible to vote at a meeting of Directors.

## ARTICLE VII

### Parliamentary Authority

**A.** The rules contained in Robert's Rules of Order, Seventy-fifth Anniversary Edition, or any subsequent edition, shall govern this association and its various bodies in all cases to which they are applicable and in which they are not inconsistent with the Constitution of By-Laws or Special Rules of Order of this Association.

**B.** The order of business of any meeting of this Association or its various bodies shall be:

1. Call to order
2. Roll call of voting members
3. Ascertainment of quorum
4. Reading of the minutes of previous meeting & approved
5. Report of the Secretary-Treasurer
6. Report of Special Committees
7. Reading of communications
8. Old Business
9. New Business
10. Adjournment

## RECALL

**Section 1.** Any member of the Executive Committee may be removed from office with or without cause as herein provided. A recall petition(s) demanding the removal of such officer shall be submitted to the Grievance Committee of the Association. Such recall petition(s) shall be signed by at least twenty-five percent (25%) of the current members of the Board of Directors.

**Section 2.** Petition forms shall be provided to any Director requesting same following the filing of an affidavit by one or more Directors with the Grievance Committee stating the name of the Director or officer sought to be removed. The Grievance Committee shall record the name of the director about whom petition forms were issued, the date of such issuance and the number of forms issued, certifying on each form the date and the name of the director to whom it was issued.

**Section 3.** All forms comprising a recall petition shall be assembled and filled with the Grievance Committee within forty-five (45) days of the affidavit filing required in Section 2, above. The signature of the petitioners shall be properly notarized.

**Section 4.** In the event that the required number of properly verified signatures to said recall petition are not received by the Grievance Committee within forty-five (45) days of the affidavit filing required in Section 2, above, the Grievance Committee shall notify those directors having filed petitions that the recall petition was insufficient and that said insufficiency does not prejudice the filing of a new affidavit for the same purpose.

**Section 5.** Not more than five (5) days following determination by the Grievance Committee that the petition(s) received are insufficient, they shall notify in writing the officer whose removal is sought by such action. This notice shall be delivered in hand or shall be delivered by certified mail. If said officer does not render his resignation within seven (7) days of receipt of such notice, the Grievance Committee shall within fifteen (15) days of the aforesaid determination, direct and conduct an election by mail ballot of the Directors of the Association. Said balloting must be

completed and returned to Grievance Committee the no less than fifteen (15) days after direction of same.

**Section 6.** The aforesaid ballots shall conform to the following requirements: With respect to each person whose removal is sought, the question shall be submitted, "Shall \_\_\_\_\_ be removed from the office of \_\_\_\_\_ by recall?" Immediately following each such question shall be printed in the ballot the two (2) propositions in the order set forth: For the recall of (name of person) and against the recall of (name of person). Immediately to the left of the proposition shall be placed a square in which the Director by making a cross mark (X), may vote for either such propositions.

**Section 7.** Should a majority of votes cast at a recall election be against the removal of the officer named on the ballot, such officer shall continue in office for the remainder of his term, subject to recall as before. However, no recall petition shall be filed against an officer within ninety (90) days after such recall petition has failed to remove him/her. If a majority of the votes cast at a recall election be for the removal, he/she shall be deemed removed from office

## **GENERAL RULES**

**Approved by the Board of Directors October 26, 2006**

### **101. Standing Committees**

**A.** All Standing Committees shall consist of an odd number of members not less than three to be appointed by the President of this Association from Association members in good standing. In making appointments to the committees, the President shall appoint committee members for not less than one year, and not more than three years. Committee members may serve more than three years with approval of the Executive committee to be reviewed yearly. Future appointments to fill vacancies shall be by the President with the advice and consent of the Executive Committee.

**B.** All committees of this Association shall function within the scope of the By Laws of this Association. All committee meetings shall be conducted according to Article VII of these By Laws.

**C.** Official business may not be conducted at Committee meetings unless a quorum is present.

**D.** A committee meeting quorum shall consist of the chairman and a majority of its members present.

**E.** All committee Chairmen shall submit a budget for the next fiscal year at the Annual Meeting for approval by the Board of Directors. The budgets once approved, cannot exceed the total amount set forth by more than ten percent without a majority vote of the Executive Committee.

**F.** The Chairperson and Vice Chairperson of each Committee shall be appointed annually by the President and a listing of all committee members shall be published in the mule industry publications and on the Official NASMA website as soon as possible after the Annual Meeting. The chairperson shall only vote in case of a tie.

**G.** The Standing Committees at present are:

**1. General Show and Contest Rules Committee** adhering to the rules and procedure in Section 102 of the NASMA Official Handbook, will receive, review, and publish on the Official NASMA Website proposed Rule Changes 30 days before submitting changes to the Board of Directors for approval. This committee has no authority to amend, change, add or rewrite any Bylaw of this Association.

**2. Judges Committee:** will establish and publish on the Official NASMA Website criteria to be met in order to become a NASMA carded Judge. In addition, this committee will receive, review and approve applicants for NASMA judges. Section 135

**3. By Laws Committee:** chaired by the President Elect and adhering to the rules in Article VII of the NASMA By Laws, will receive, review and publish on the Official NASMA Website proposed Bylaw changes before submitting changes to the Board of Directors for approval.

**4. Show and Contest Sanctioning Committee:** adhering to the rules and procedure in Section 103 of the NASMA Official Handbook, will receive, review and approve NASMA recognized shows.

**5. Youth Committee:** will review and approve applicants for NASMA Youth Association and implement the development of By Laws for NASMA Youth as the governing body of youth activities in NASMA and advancing the ideals of NASMA including good mulemanship, donkeymanship, good sportsmanship in competition, trail riding and family activities.

**6. Versatility Trail Program Committee** will receive, review and approve applicants for VTP and establish criteria for achievement levels, awards programs to be approved by the Board of Directors. The committee will encourage promotional trail events and submit information to the Official NASMA Website for publication activities and honors.

**7. Scholarship Committee:** will receive, review and approve applicants for NASMA for the annual award of two \$500 scholarships to NASMA seniors in high school who have met the criteria and will be continuing their education and submit information to the Official NASMA Website for publication activities and honors.

**8. Awards Committee**

**9. Amateur Committee:** will receive, review and approve applicants for NASMA Amateur status adhering to the rules outlined in Section 147, E.

**10. World Show Committee**

**11. Grievance Committee** adhering to the rule for Recall Article VIII of the By Laws, Violations Section 110, Fraudulent Practices Section 111, Disciplinary Action Section 112 and Appeal of Show Protest Decision Section 141, C. of the NASMA Handbook will receive complaints, review evidence, conduct hearings and recommend action for Board of Director approval.

**12.** Special committees may be appointed by the President from time to time to attend to special business. These committees serve for the duration of the special problem or until replaced or until the committee is disbanded.

## **102. Proposed Rule Changes**

**A.** A NASMA member, a standing committee, the Board of Directors, the Executive Committee or the NASMA staff may propose a Rule Book change. A Rule Book Change is any change or an addition or deletion to any other rules contained in the NASMA Handbook, not to include the Articles of By-laws

**B.** Whenever a Rule Book change in the Rule Book is proposed, the rule with the reason and intent of the proposed changes should be directed to the NASMA General Show & Contest Rules Committee with a postmark, Official NASMA Website Submission, or e-mail no later than February 1 of the last year for which the current NASMA Handbook applies

**C.** All proposed Rule Book Changes shall then be reviewed by the NASMA General Show & Contest Rules Committee and placed in proper and legal wording. The NASMA General Show & Contest

Rules Committee cannot change the intent of the rule as it was received from its original source.

**1.** Chairman will receive from members, committees and judges suggested rule changes containing:

- a.** Name of submitter
- b.** Existing Rule Number and Page# in current Rule Book
- c.** Related rule numbers affected by this proposed rule change
- d.** Recommendations for Change (Recommendation should be written as it might appear in the Rule Book)
- e.** Justification for rule change
- f.** Impact if rule is NOT changed

**2.** Chairman will disseminate rule change submissions to committee members for review.

**a.** Individually and as a group, the Committee will review and, if needed, make changes to suggested submissions making sure the intent of the submission are not compromised following the format of the rule book.

**b.** Chairman will:

- (1)** contact the submitter for any clarification of meaning or wording;
- (2)** if there is a re-write of the rule change submission, return the rule to the submitter for approval of language and explaining reasons for changes and requesting the submitter endorse the changes;
- (3)** if the Committee fails to endorse the rule change submission, contact the submitter explaining the reason for non endorsement;
- (4)** Chairman will return endorsed rule changes to the Committee.

**c.** By April 15<sup>th</sup> the Committee will publish on the NASMA website proposed rule changes in the exact wording and form in which they will be submitted to the Board with the following information

- (1)** Existing Rule Number and Page# in current Rule Book
- (2)** Related rule numbers affected by this proposed rule change.
- (3)** Recommendations for Change (Recommendation should be written as it might appear in the Rule Book).
- (4)** Justification for rule change.
- (5)** Impact if rule is NOT changed

**3.** The proposed Rule Book Change, legally and properly worded, will be published on the Official NASMA Website at least ninety (90) days before the meeting at which they will be presented for approval by the Board of Directors

**a.** The Chairman of the General Show and Contest Rules Committee presents rule changes at Board of Directors meeting for approval.

- (1)** If changes are approved by the Board, Committee incorporates them into new Handbook.
- (2)** If changes are not approved by the Board, Committee returns them to submitters to do with as they choose.

**4.** A Rule Book Change cannot be voted on by the Board of Directors until it has passed in the proper Standing Committee, however, all submitted rule changes, whether pass by the Standing Committee or not, must be publicized to the Board regardless of quality or pertinence. NOTE: A Rule Book Change that was defeated in proper Standing Committee

may be brought out of the Standing Committee by presenting a petition signed by ten (10) eligible Directors to the NASMA President. This petition must be presented to the President fifteen (15) days prior to the Meeting that proposed Rule Book Changes will be presented for approval by the Board of Directors.

**5.** If the proposed rule change brought out of committee by petition, the Chairperson will read the proposed Rule Book Change in the committee report to the Board of Directors. The Rule Book Change is thus on the floor and subject to amendment by a member of the Board of Directors. However, any amendment must be closely related to or have bearing on the Rule Book Change. The priority of any amendment will be decided by the Presiding Officer or Parliamentarian. If a motion for amendment is received and seconded, the amendment must be voted on at this time.

**6.** The proposed Rule Change, if amended, will be returned to the Rules Committee for review and any proper or legal wording. The Rules Committee cannot change the intent of the Rule Book Change as amended.

**7.** All proposed Rule Book Changes to be voted on by the Board of Directors will be published in the mule industry publications and on the Official NASMA Website thirty (30) days before the meeting at which they will be presented for approval by the Board of Directors

**8.** At the Association's Annual Meeting or Special Meeting, the Board of Directors will approve or reject the recommended proposed Rule Book changes exactly as written (no further amendments). If the proposed Rule Book Change is approved, it will then be printed in the Rule Book and become binding whenever the next scheduled printing occurs. If the proposed Rule Book Change fails to obtain approval, it can still be considered for a future Rule Book change provided it is sent back to the NASMA General Show & Contest Rules Committee following all the above procedures.

**9.** If a proposed Rule Book Change is considered of such extreme importance by the standing committee that it must be acted upon immediately, such proposed Rule Book Change must be presented to the Executive Committee fifteen (15) days prior to any Regular or Special meeting of the Board of Directors. If, in the opinion of the Executive Committee, such proposed Rule Book Change is important to the best interests of the Association, it can then be presented by the Chairperson of the NASMA General Show & Contest Rules Committee to the Board of Directors for immediate action and, if approved, can become effective immediately with notice in mule industry publications, on the Official NASMA Website, e-mail and USPS mail.

## **103. Regional Clubs**

**A.** Only the National Association is empowered to use the term Association in its title without being retroactive.

**B.** All clubs shall be referred to as regional clubs and shall be under the supervision of the National Association through the Executive Committee and the Regional Club Committee.

**C.** Charter and By Laws must conform to the laws of the State of Incorporation and the main charter of NASMA. Every club shall follow standard procedures as set forth in the NASMA By Laws or rules must contain the following mandatory procedures which must be enforced.

**1.** Clubs must be formed only for advancing the mule through the ideals of NASMA including good mulemanship and good sportsmanship.

**2.** Every regional club shall have biannual office and director elections. Each regional club shall have a president, vice

president, secretary, treasurer and a minimum of three directors with at least one of the directors or officers serving as liaison to the National Association.

**3.** Regional clubs must have their current list of officers on file in the National Office by February 15 each year or approval of any of these clubs next years shows will be withheld until officers have been submitted to NASMA.

**D.** Results of regional club elections shall be furnished to each member in good standing no later than thirty days after election. Notification shall be in writing in addition to introductions or installation at the annual membership meeting. This written notification may be in the regular club newsletter.

**E.** The date of the regular annual meeting of the members shall be set forth in the By Laws, and provisions as to notice shall be according to rules of the State of Incorporation.

**F.** The Treasurer or an officer of the Association shall return a complete treasure's report at the regular annual meeting of the members of the regional club and shall prepare at least one annual budget. The treasure's report shall be distributed to each member standing. The club shall return a treasure's report and budget at each regional club meeting if requested or required by the Board of Directors or members. All funds generated by all activities within a regional club or affiliate of the Club including activities of Special Interest Clubs or special interest committee, fund, activities, etc. must be accounted for to the Regional Club. Each regional club must submit by February 15 of each year the proposed budget for the coming year and the actual expenditures from the previous year. These shall be submitted in an approved format as set forth by the regional Club Committee. Regional clubs must maintain on file receipts and documentation for expenditures of their regional club budget for at least five years.

**G.** When any group shall desire to form a new club, the group shall sign a letter thirty days before the organizational meeting setting forth the name of the chairman, the time and place, and the specific geographical area to be encompassed. That letter shall include a map of the proposed area, and must set forth 10 proposed dues paying members of which at least 5 shall be current members of NASMA. The final approval of the new club shall be only after full examination of the situation involved and the effect on any club already formed. Request for approval shall be forwarded to the Regional Club Committee; final approval shall be by the Executive Committee of NASMA. In no case shall a club be formed that infringes on another club or that might create an adverse effect on any club already formed. Should there be any indication of a possible adverse effect on any club already formed, the Regional Club Committee shall review all controversial requests and submit their recommendations for final approval by the Executive Committee of NASMA.

**H.** The name of any group requesting recognition as a regional club, and the proposed area will be published in the mule publications and no club shall receive final approval until thirty days after such publication.

**I.** If there is a demonstrated lack of activity that can be construed by the NASMA Executive Committee or Regional Club Committee as a lack of necessity for the regional club, the Regional Club Committee, when authorized by the Executive Committee of NASMA, shall review the status of the club charter and make recommendations to the Executive Committee relative to the same, including suspension or revocation. Minimum activity for a regional club shall be at least two organized activities annually.

**J.** Any club rules contrary to those set forth in the Charter, By Laws and Rules of the Association shall immediately forthwith be altered and amended to conform to same.

**K. Special Interest Club (Amateur, Trail, Youth, etc.)** Any group desiring to form a Saddle Mule Special Interest Club (Amateur, Trail, Youth, etc.) must make application to their NASMA Regional Club as to the reason and necessity for their formation and shall submit their completed By Laws and Constitution for approval.

**1.** A Special Interest Club By Laws and Constitution shall coincide with the NASMA constitution and the constitution of their parent Regional Club. This Special Interest Club is not considered by NASMA to be a separate entity from the parent Regional Club; that is, it will be considered a subsidiary or affiliate of the parent Regional Club.

**2.** Each Special Interest Club must conform to all rules of NASMA and its parent Regional Club.

**3.** A minimum of 5 Special Interest Members is required to form a Special Interest Club.

**4.** Special Interest Clubs must be paid up in their parent Regional Club dues.

**5.** A liaison from the Board of Directors or a member of the parent Regional Club shall be appointed by the parent Regional Club to coordinate the activities of the Special Interest Club and the parent Regional Club.

**L. A Regional Club may sponsor and hold NASMA shows.** To do so a Regional Club must adhere to all of the requirements as set forth in the official rules and regulations of NASMA in making application for NASMA show sanctioning. Shows may be A, B, C shows and will follow the requirements set forth in each category.

**1.** Any Regional Club may hold a Regional Championship show. Only one regional Championship show may be held in each NASMA region yearly. This show must be an A show and follow all NASMA sanctioning rules. Show sanctioning Committee authorization will be required to call the show a Regional Championship. If more than one regional club from a Zone would like to hold the Regional Championship, the Show Sanctioning Committee may require those clubs to work together to hold the show. The Show Sanctioning Committee may refer any disputes in this area to the Executive Committee of NASMA for final resolution.

**2.** The following titles will be reserved for Regional Championship shows.

**a. NASMA REGIONAL CHAMPIONSHIP SHOW**

**b. NASMA REGIONAL CHAMPION MULE**

**3.** Shows held by Regional Clubs will conform to NASMA rules governing sanctioned shows. Regional clubs may hold schooling shows and other play days that do not adhere to these rules. Humane treatment of horse, mules and donkeys at these events shall always be adhered to.

**M. Regional clubs shall be able to give yearend awards for their membership.** Yearend awards may cover any categories that Regional Club so desires. The title of the award must include that Regional Clubs name and not infringe on any other Regional Club or the Associations yearend or other award programs. Yearend point tabulations are to be based on points earned only after the dues of the National Associations and Regional club are paid.

## **104. Membership**

**A. Membership is a privilege, not a right, application for which shall be made by procedures prescribed by NASMA.** Membership or application, therefore, may be terminated or rejected by the Board of Directors for cause detrimental to the interest of NASMA, its programs, policies, objectives and harmonious relationship of its Members as determined by the Board of Directors. Termination or application rejection proceedings in this Bylaw shall be conducted under NASMA's disciplinary procedures for notice, hearing and temporary suspension and presided over by the Grievance

Committee. The effect of termination or rejection may be denial of privileges of NASMA as set forth in NASMA disciplinary procedures. *Termination of NASMA Membership either by court order or court mediation shall prevent that member whose membership has been terminated, resigned from or denied due to such legal action will be ineligible for the consideration of their application.*

**B.** Each Membership is entitled to one vote and shall not be limited to natural persons, but may include corporations and partnerships. Proper receipts and membership cards shall be issued upon payment of fees.

**C.** Membership shall consist of six categories

1. Annual Membership,
2. Amateur Membership,
3. Ten Year Membership,
4. Lifetime Membership,
5. Youth Membership and
6. Charter Membership.
7. Family Membership

**D.** The application for membership should indicate clearly the name in which the membership is to be recorded. Any registration or transfers submitted utilizing the Membership shall be recorded in the same exact name as that appearing on the Membership or a nonmember fee will be charged. In no case shall the Membership name exceed 30 (letters and spaces). Members shall be admitted to the Association on a written application accompanied by the current membership fee. By applying for membership the applicant automatically agrees to be bound by and to abide by all rules, regulations and policies of the Association.

**E.** The name of a member may be changed in the membership records of the Association to reflect a change of name. Such a change shall be made upon submission of documentation (i.e. marriage license, court decree, etc) reflecting a change of name by said member

**F.** A membership fee is neither transferable nor refundable. General privileges and responsibilities of members and nonmembers are as follows:

**G.** All members shall have equal rights, interest and responsibilities with respect to the Association and its property; shall obey and be bound by all By Laws, Rules and Regulations of the Association and decisions or actions of the Board of Directors or Executive Committee; shall have the right to vote in the National Director Election if a Regular or Charter member before January 1 of the year of the election shall have the right to vote by personal attendance at membership meetings and shall have the right to hold office and committee assignments in accordance with criteria in this NASMA Handbook, except as otherwise limited.

1. In regard to individuals' who are nonmembers, participation in Association approved events by such actions and in regard to such transactions, do thereby agree to be bound by all By Laws, Rules and Regulations of the Association.

2. Membership does not include a subscription to any of the industry publications.

**H. ANNUAL MEMBERSHIP:** Annual membership is considered to be a period from January 1 through December 31 of a calendar year. An annual fee of twenty dollars (\$20) shall be paid for each Annual Membership. Renewal notice to the members shall be sent to their last known address not less than thirty (30) days prior to the end of the calendar year and posted on the Official NASMA Website. When an annual membership expires, the membership can be reinstated by simply paying the current year's annual fee.

1. Any member whose membership becomes delinquent can be reinstated by paying the current year's dues. There is no

penalty for reinstatement. However, no points or VTP hours can be accrued during the time the membership was delinquent.

2. Regular Memberships may be paid in advance in three to five year increments based on the calendar year (January 1 through December 31)

**I. CHARTER MEMBERSHIP:** A fee of \$200.00 is required for a Charter Membership but no annual fees are required thereafter. This is a lifetime membership. This Charter Membership must be applied for prior to January 1, 1995. A Charter Member shall be entitled to a Charter Membership pin, and the purchase of an official Charter Member silver belt buckle at club discount.

1. A Charter Membership is not transferable, but a Charter - Membership may be carried in the joint names of husband and wife.

2. If a Charter Membership is carried in a single person's name, the name of a later spouse may be added by onetime amendment.

3. The President and Past Presidents shall receive a Charter Membership and shall receive all benefits of such membership.

**J. TEN YEAR MEMBERSHIP:** A fee of \$120 is required for a Ten Year Membership, but no annual fees are required thereafter for ten years.

1. A Ten Year Membership is not transferable, but a Ten Year Membership may be carried in the joint names of husband and wife.

2. If a Ten Year Membership is carried in a single person's name, the name of a later spouse may be added by onetime amendment.

**K. LIFETIME MEMBERSHIP:** A fee of \$250 is required for a Lifetime Membership, but no annual fees are required thereafter.

1. A Lifetime Membership is not transferable, but a Lifetime Membership may be carried in the joint names of husband and wife.

2. If a Lifetime Membership is carried in a single person's name, the name of a later spouse may be added by one-time amendment.

**K. AMATEUR MEMBERSHIP:** An annual fee of \$10 in addition to the regular NASMA membership fees is required for an exhibitor to be eligible for amateur status. An amateur membership application must be approved by the NASMA Amateur Committee before a person is granted amateur status. Please refer amateur guidelines covered elsewhere in this rule book for current regulations concerning amateur status.

**L. FAMILY MEMBERSHIP:** An annual fee based on 20% less than what a family group of 3 or more would pay if counted as single fees.

## **105. Television and Media Coverage**

**A.** Attendance at an NASMA approved event, in whatever capacity, shall constitute authorization for NASMA, its agents, designers, or assigns to photograph, video tape, televise, or record by other means (hereinafter referred to as photographic material).

**B.** The photographic material and related information referred to above may be used in any manner that the NASMA, at its sole discretion, determines would be beneficial to promoting the purposes and goals of the NASMA; provided, however, that no photographic material or related information will be used in conjunction with the endorsement of any product unless prior written consent is obtained. Attendance at an NASMA approved event shall further constitute agreement to the terms and conditions outlined above, and shall constitute a waiver and release, within limitation, of any individual television, radio, motion picture, photographic or other similar rights, including right of privacy, any person or animal may have in or to such photographic material or

related information when such information is obtained at an NASMA approved event by the NASMA, its agents, designees, or assigns.

## **106. Responsibility**

**A.** The North American Saddle Mule Association will not assume the responsibility of settling civil disputes concerning financial settlements or ownership

**B.** No person shall refuse the reasonable request to assist the Association, its officers, committees or agents in locating, identifying and inspecting or to answer promptly and truthfully any inquiry concerning an animal or ancestor thereof in his ownership or control, which has been registered or listed, for which application to register or list has been made, or to sign requested documentation. A violation of this rule may be grounds for disciplinary action.

**C.** In the furtherance of their official duties, all Association representatives shall be treated with courtesy, cooperation and respect and no person shall direct abusive or threatening conduct toward them.

**D.** All information furnished the Association as a basis for any action by the Association or any of its officers shall be true and correct. This includes, but is not limited to, registration applications, application for show approval, and all information in regard to Association investigation of third parties.

**E.** Accuracy of records furnished by the Association, either as hard copy or online service, is warranted by the NASMA only to the extent of serving its best efforts in the compilation thereof and then solely for the benefit of the member or party purchasing the record. Reimbursement of the expense of the record on a showing of material inaccuracy is the sole remedy available to anyone receiving inaccurate information from the Association. Consequential damages are expressly excluded. No warranties, state therein, as the purchaser receives this record on an "as is" basis. For absolute accuracy, independent verification must be obtained from the current owner or his predecessor in title to the subject mule.

**F.** In all proceedings concerned with or affecting the registrations and records of the Association and in all disciplinary actions the burden of resolving any doubt as to the true identification of an animal or the accurate recording of the show records shall be upon the applicant, owner, lessee or other member (s) or non-member(s) involved. The determination, decision or action taken by the Executive Committee upon all such questions shall be final and binding upon all parties. As the owner has the burden of proof, by failure to present evidence concerning such questions to the Association or at a hearing scheduled to resolve the question, the owner shall be deemed to have waived his right to later present such evidence in a court of law, if he seeks judicial review of the Association's action.

**G.** When an exhibitor, owner or trainer is guilty of unsportsman-like conduct, such person is subject to disciplinary action by the NASMA, including but not limited to, fines and/or suspension

## **107. Liability**

The NASMA, its officers, directors, and members of committees, inspectors, employees, representatives, and agents will attempt to obtain true and complete information in connection with registration, transfers of registrations, hearing, show records, and all other matters relating to NASMA activities. Except for proven intentional wrongdoing, neither the NASMA nor its officers, directors, members of committees, inspectors, employees, representatives nor agents will be liable in any way, whether in damages or otherwise, for issuance of show records, hearing records, disciplinary procedure brought against or penalties

imposed on any member of any person or of any other activities engaged in by or on behalf of the North American Saddle Mule Association.

## **108. Release of Liability**

The NASMA and cosponsoring organizations, if any, shall not be responsible for any personal injury, or for loss or damage to property, occurring at any NASMA activity. Each owner, exhibitor, handler, or consignor shall indemnify and hold harmless the NASMA, its officers, directors and employees from and against all claims, demands, causing of actions, and expenses of every kind, including attorney's fees, arising out of or related in any manner to the actions or omissions of an owner, exhibitor, handler, or consignor, or the actions of any animal under the care, custody, or control of the owner, exhibitor, handler or consignor. Presentation of signed entry or consignment forms shall be deemed acceptance of the conditions of this rule. In the event an entry or consignment form is not signed or presented, appearance on the grounds or at the sale ring of NASMA activities as an exhibitor, handler, owner, or consignor shall be deemed to be acceptance of the condition of this rule.

## **109. NASMA Funds**

**A.** Any and all fees or monies due the NASMA are the property of the NASMA upon collection and shall be turned over to the Association within thirty (30) days of collection. The officers of such club and/or individuals responsible for the collection and disbursement of such funds shall be personally liable and, in addition, subject to the rules pertaining to violations and disciplinary action.

**B.** Any and all fees or monies due NASMA must be paid in U.S. funds only.

## **110. Violations**

**A.** Any member may be suspended and denied privileges of the Association, any nonmember may be denied the privileges of the Association by the Board of Directors of the Association for failure to pay when due any obligation owing the Association. This includes but is not limited to, an approved show, or for giving a worthless check for entry fees, stall fees, office charges, stock charges or any other fees or charges including bank charges for returned checks connected with exhibition of mules. Fifteen (15) days before action by the Board of Directors written notice of the account due or delinquent accounts and the intention to suspend or withhold privileges of the Association shall be mailed to such member or nonmember. Upon suspension by the Board of Directors, the name of the member or nonmember may be published in a Suspension Listing document available upon request from the NASMA office. Any suspension and denial of privileges the Association under this section shall terminate upon full payment of the obligations due the Association or upon filing late fees due.

**B.** Any person guilty of the following:

- 1.** failure to pay an obligation owing to the Association;
- 2.** giving a worthless check for entry fees, stall fees, office charges connected with the exhibition of mules and/or donkeys;
- 3.** suspension from one of the horse breed or donkey & mule associations;
- 4.** found guilty in a court of law of animal abuse and upon submission of certified evidence of such conviction from any court

**C.** Such person, whether member or nonmember, will be subject to disciplinary procedures insofar as practical.

**D.** Every member and nonmember who violates the By Laws or Rules and Regulations of the Association as documented by the Grievance Committee's investigation and the subsequent finding of the Board of Directors may be censured, suspended or in the case of a member, expelled from membership in the Association and denied all privileges of the Association.

## **111. Fraudulent Practices**

**A.** No person shall present any animal owned or managed by him/her to be registered unless the same be registered in the officially accepted registry of NASMA. This is included, but not limited to, entry forms and advertising.

**B.** No person, firm or corporation shall issue, sell, exchange, give away or receive, or offer to day any thereof, any false or fraudulent certificate representing same to be a genuine official certificate issued by the Association.

**C.** No person shall advertise, or enter in any NASMA event or competition any registered or listed with the Association by a name other than that by which is registered or listed. No change in or alteration of a certificate of registration or listing or identification required by the Association shall be made except by the Association or its official representative upon proper showing of the necessity for such change or alteration by reason of change in color or markings, mistake or the like; nor shall any person display or advertise or have in his possession any such certificate that has been changed or altered otherwise, other than by the Association or on its authority.

**D.** No person shall alter in any way, change or attempt to hide or alter the natural markings of a mule by surgery, dye or any other manner.

**E.** No person shall represent as a registered Saddle Mule any mule other than the mule for which said certificate was issued.

## **112. Disciplinary Action**

**A.** Any member may be disciplined, suspended, fined or expelled from the Association, any member or nonmember may be denied any and all privileges of the Association whenever is has been established that satisfactory evidence that such member or nonmember has violated any Bylaw, rule, or regulation of the Association.

**B.** A NASMA form for filing protests, with proper documentation. Should be filed such that the protestor understands that

1. he will not approach or call anyone else about the situation, and

2. if any of the information is missing, the protest is null and void,

3. There will be no resubmitting of this protest and the fee is forfeited.

4. A check sheet of all documentation required is included with the form, and it should be signed by the protestor before submitting it to the Grievance Committee, by certified mail, return receipt requested.

**C.** The Grievance Committee shall have sole authority to investigate possible or alleged violations of any by law, rule or regulation of the Association. The Grievance Committee will gather all needed information, the \$100.00 protest fee, and substantiate the need for further investigation, and then will transfer the documentation to the Board of Directors with no names mentioned.

1. If a members of the Grievance Committee is involved in any protest, she/he should be removed from the voting procedure;

2. More members of the Grievance Committee are involved, alternate members should be appointed to serve temporarily Grievance Committee.

- 3.** All grievances are to go to the Chairman of the Grievance Committee. The Chairman of the Grievance Committee will make the grievance anonymous before submitting it to the Grievance Committee for vote.
- 4.** i.e. "A" files a grievance against "B", complete with a check list, and submits it to the Chairman of the Grievance Committee. The Chairman of the Grievance Committee confirms the checklist is complete, and the fee has been received. The Chairman of the Grievance Committee notifies "B" without naming "A" and asks for response/defense within 14 days from confirmed receipt of notification. Then the grievance and defense are submitted to the Grievance Committee for determination within 21 days of confirmed receipt.
- D.** In order for a complaint, other than one which can be verified by credible testing, to be considered for investigation it must be
  - 1.** in writing,
  - 2.** signed, dated and
  - 3.** accompanied by \$100 Protest Fee
- E.** The protest must be submitted to Grievance Committee the along with the proper paper work.
- F.** The individuals filing the complaint must be prepared for full discourse of the complaint to the party (parties) concerned in the complaint and must be prepared to appear at a hearing if it is deemed necessary.
- G.** When it is determined by the Grievance Committee that there is sufficient cause for a hearing the person charged with any alleged violation shall be given not less than twenty-one (21) days' notice of a time and place for hearing such allegations by the Grievance Committee at which time and place he/she shall have the opportunity, in person or by counsel, to be heard and to produce evidence in his/her own behalf, and to hear and receive evidence offered against him/her. If the person charged has not been heard from by Grievance Committee after the 21 day period he/she shall forfeit his/her right to a hearing.
- H.** The Grievance Committee shall have the authority to schedule a disciplinary hearing when it determines that there is sufficient verifiable evidence for a hearing. Additionally, a disciplinary hearing shall be held if it is requested by one half of the members of the Board of Directors, Executive Committee or by the President.
- I.** A committee meeting quorum shall consist of the chairman and a majority of its members present.
- J.** Testimony may be taken at a hearing via telephone or video conference. Any person desiring to present testimony via telephone or video conference should notify all involved person(s) in writing, at least five (5) days prior to the scheduled meeting. This notice should contain the name, address and telephone number of each person who will testify via telephone. This provision is not intended to limit or preclude other appropriate procedures for offering testimony or evidence at hearings.
- K.** No continuance shall be granted unless requested in writing at least seven (7) days prior to the hearing, and good cause is shown. A Continuance shall be granted or denied at the sole discretion of the President.
- L.** The Grievance Committee will make a report of its findings, to include copies of all evidence and testimony to the Board of Directors whose decision and action shall be final and binding on all parties.
- M.** In regard to any violation of Show and Contest Rules, as a part of its disciplinary action, Board of Directors may revoke participation privileges in all NASMA approved event(s) for determined period of time.

**N.** Pending final hearing by the Board of Directors the Grievance Committee may, by giving written notice of its action, temporarily suspend the said member in cases of criminal proceedings against that member for animal abuse until criminal charges are dropped or the member is found innocent in a court of law,

**O.** On or after such time as any person has been denied participation privileges in NASMA approved events, but that his membership privileges are not effected, the following restriction shall apply:

1. That person shall not be eligible to participate in any NASMA approved event.

2. That person shall not be eligible to hold approved judge's credentials or any other Association accreditation:

3. Mules which are recorded in the name of such person or owned in whole or in part by such person are not eligible to participate in any NASMA approved event.

4. During the period of denial of Association privileges, failure to comply with these restrictions and any other express conditions or restrictions of said disciplinary actions may constitute grounds for further disciplinary action.

**P.** When a member is disciplined, suspended, expelled or fined, or a nonmember is denied membership privileges, the name and Address of such member or nonmember will be published in a Suspension Listing document available from the NASMA office.

**Q.** See Section Show and Contest Rules for Additional provisions.

**R.** In the event any disciplinary action is taken against a member or nonmember, publication of the action shall be made as soon as possible in the Suspension Listing Document available from the NASMA office and shall include rule number violated for disciplinary action to have been assessed.

**S.** On or after such time as any person has been suspended, expelled or denied further Association privileges, in addition. To other provisions of this handbook or policy of the Association, the following restriction shall apply:

1. That person shall not be ineligible to earn points at any sanctioned NASMA events or accrue VTP hours

2. Nor shall such person be eligible to hold approved judge's credential or any other Association credentials.

3. Signatures:

a. The Association shall not accept the signature of such person, on any entry forms for Association approved or recognized events.

b. The signature of such person will be recognized on a bill of sale of a mule to another non-family member.

**T.** During the period of expulsion, suspension or denial of Association privileges, failure to comply with these restrictions and any other express conditions or restrictions of said disciplinary action may constitute grounds expulsion from the Association.

**U.** The provision of the disciplinary rules which pertains to notice and hearing procedure shall also apply to hearings regarding registration issues.

**V.** The Association has adopted the following provisions for the mutual benefit of members and with the intention of reducing the Association's litigation expenses, which expenses would ultimately be borne by members and nonmember participating in Association activities. Every member, by joining the Association, or nonmember, by participating in NASMA approved activities does thereby agree as follows:

1. If unsuccessful in an attempt to overturn Association decisions, actions, rules or regulations, to reimburse the Association for its reasonable attorney's fees, court costs and other expenses in defense of such suit; and

2. That he/she will not commence any action, whether in law or equity, against Association in any courts other than those federal and state courts in Wise County, Texas.

**W. GENERAL NOTICE PROCEDURE:** Notice required by these rules and regulations may be served by delivering a copy of the notice to the person to be served, or his attorney, either in person or by mail, postage prepaid, to his last known address as it appears on the Associations records, and upon mailing such notice shall be deemed received by such person when it is deposited in the United States mail.

## 113 Show Approval

**A. Request for Approval:** Any organization, club or individual may request their show or contests and the results be recognized by NASMA. Application forms must be obtained from the NASMA.

**B. Withholding approval of regional club-sponsored shows** will be in accordance with rules outlined in this rule book.

**C. Application** An application form(s) shall be postmarked (postal meters are not acceptable) to the NASMA at least ninety (90) days prior to the show or contest entry deadline or show date, whichever comes first. Any application mailed from outside the continental U.S. must be postmarked on hundred (100) days prior to the show or contest entry deadline or show date, whichever comes first. The application(s) must be accompanied by a *fee of* twenty-five dollar (\$25) for members, fifty (\$50) for non members per show or contest. The amount of twenty five dollars (\$25) will be refunded to show management who submit show result within two (2) weeks from last day of show or contest (postmark). After receiving an application for NASMA show or event sanctioning, the show and event sanctioning committee will review the application to determine if the requirements for sanctioning are met. Although requirements may be met, the committee will decide if it is in the best interest of NASMA to sanction the show or event.

**D. NASMA FEE:** Show Managers must collect two dollars (\$2) per every mule and donkey (excluding miniature donkeys and hybrids) entered in any NASMA show for processing show results, unless waived by the Board of Directors.

**E. Approval of Class List:** Approval of show will not be granted until a list of classes in scheduled order for such is show is received by the NASMA. Once the list is submitted, the list of classes can be amended up to 30 days prior to the show by written notification to NASMA.

**F. Show or contest officials** will be notified by the NASMA if their show or contest is recognized or what fact(s) need to be rectified so that the show or contest may be recognized. If a certain class is not recognized, it may not prohibit the recognition of the remaining classes.

**G. Mileage Between Shows:** The show may be approved on the same dates as another NASMA approved show if the two are not located within 250 highway miles of each other, with the exception of state, regional and county fairs, and major livestock shows which may be on the same as another approved show despite proximity. The last sponsor of any individual show has the right to sponsor the show in the following year, provided their application complies with SC 112 C & D

**H.** The mileage limitation between shows does not apply to shows between Canada and the U.S...

**I. Dates:** Show applications are approved based upon the number of the weekend, not upon the date. The number of the weekend is determined by counting from the first Saturday of year. The first Saturday of January is assigned number 1. The remaining weekends are consecutively 2-52.

**J.** Show dates are not the property of individuals or clubs. In the event the previous sponsor does not obtain approval for the show date, then the regional or state club has first priority on the date.

**K. Cancellations:** Sponsors of shows who cancel their shows dates must notify the NASMA Performance Division immediately so that date can be made available to another sponsor.

**L. GOVERNING RULES:** These rules as set out in the NASMA rule book shall be used at all approved shows, unless otherwise approved by the Board of Directors of NASMA. The schedule of classes and premium published for any NASMA-approved show shall state "Rules in accordance with The North American Saddle Mule Association Rule Book"

**M.** All shows or contests recognized by NASMA shall be named, advertised, listed and otherwise referred to as a Saddle Mule Show. The name of the show or contest may not include words referring to other breeds, except donkeys, and/or type of horse. The words "Champion" and "Championship" must be prefaced with the name of the specific show (i.e. "State Fair of Texas Champion") in order to identify that this is a local Championship. No individual or organization may use the words "NASMA World", "NASMA National", NASMA Mule-Arma or "NASMA International" champion without written permission of NASMA.

**N.** The following titles shall be reserved for exclusive use and permission by NASMA:

1. NASMA CONGRESS
2. NASMA WORLD CHAMPIONSHIP SHOW
3. NASMA WORLD CHAMPION MULE
4. NASMA RESERVE WORLD CHAMPION MULE
5. NASMA INTERNATIONAL CHAMPIONSHIP SHOW
6. NASMA INTERNATIONAL CHAMPION MULE
7. NASMA RES. INTERNATIONAL CHAMPION MULE
8. NASMA YOUTH WORLD SHOW
9. NASMA WORLD YOUTH CHAMPION MULE
10. NASMA RESERVE WORLD YOUTH MULE
11. NASMA NATIONAL CHAMPIONSHIP SHOW
12. NASMA NATIONAL CHAMPION MULE
13. NASMA RESERVE CHAMPION MULE

#### **O. Show Results**

1. The results of every class at any approved show or contest, giving a complete list of competing mules, including the registration names and numbers (if applicable), exhibitors' and owners' names and NASMA identification numbers, should be forwarded to NASMA within fifteen (15) days after the completion of the show or contest. Single sheet forms for reporting will be supplied to show management when the show is officially approved. Continuous form computer printed results will be accepted by NASMA, but not supplied.

2. Failure to mail the complete show results or notification of cancellation to the Association within fifteen (15) days of the last scheduled show date may result in future approval being denied.

3. Show results of approved shows and contest will be published. Corrections will be made on the mule's record only. No corrections will be published in those publications publishing the results.

4. Show Management must include a separate list of each individual mule which compete in the show, stating its registered name and number and the divisions it was exhibited in, on the form provided

5. Discrepancies between NASMA-approved show classes and classes actually offered and conducted at the show shall be presented to the Executive Committee for judgment when properly submitted by the contestant or show management

6. Show Management must collect two dollars (\$2.00) per every mule entered, not to exceed \$10 per owner, for single

judge shows and three dollars (\$3.00) per every mule entered, not to exceed \$15 per owner, for multiple judge shows and forward to the NASMA office in order for show results processed, unless waived by the Board of Directors.

## Minimum Requirements

### For Show Approval

“A”, “B”, or “C” show status is achieved as a minimum, the number of classes designated in the chart below:

Choose any classes from the following:	SHOW CLASSIFICATION		
	A Show	B Show	C Show
List 1: <b>Halter</b>	4 classes	2 classes	1 classes
List 2: <b>Senior Mule Performance</b>	5 classes	4 classes	3 classes
List 3: <b>Junior Mule Performance</b>	4 classes	3 classes	Optional
List 4: <b>Amateur</b>	4 classes	2 classes	Optional
List 4: <b>Youth</b> May be divided (18 & Under)(14-18) (13 & under)	4 classes	3 classes	1 class
List 6: <b>Driving</b> May be divided (Open) (Senior Mule) (Junior Mule) (Youth)	3 classes	2 classes	Optional
List 7: <b>Speed/Gymkhana</b> May be divided (Open) (Senior Mule) (Junior Mule) (Youth)	4 classes	3 classes	2 classes
List 8: <b>Specialty</b>	Optional	Optional	Optional
List 9: <b>Gaited</b>	Optional	Optional	Optional
List 10: <b>Cattle</b>	Optional	Optional	Optional
List 11: <b>Donkey</b>	Optional	Optional	Optional

Notice: The above guidelines are minimum requirements. Any show may include more classes than required at a certain show level and NASMA encourages local clubs to include classes for donkeys and “exotic” crosses if their numbers justify such classes. If other such classes are offered, the premium list must clearly state that such a class is “not a NASMA approved class.”

## 115 NASMA Approved Class List

When forming a show class list it is imperative to designate the type of class along with class name. (i.e.) Sr. Mule Western Pleasure; Jr. Mule Trail; Amateur Donkey Showmanship, etc.

**A. MULE HALTER CLASSES** (All Halter class may be split into separate classes for John or Molly mules or their ages may be combined. It is the option of the show management to offer Grand and Reserve Grand Championships in both sex divisions if all *Halter Classes* are divided by sex. Only "Open", non-breed specific Halter Classes, by age or height, are eligible for Grand and Reserve).

1. Weanling Mules
2. Yearling Mules
3. Two Year Old Mules
4. Three Year Old Mules
5. Four Year Old Mules
6. Four Year Old and over classes may be split into 58" & Under and 58.01" and Over
7. Any or all classes may be split into John Mules and Molly Mules
8. Gaited Classes may have the same age breakdowns but for gaited mules only.
9. Hunter type mules

### **B. SENIOR MULE PERFORMANCE CLASSES**

1. Sr. Mule Western Pleasure
2. Sr. Mule Trail
3. Sr. Mule Reining
4. Sr. Mule Western Riding
5. Sr. Mule Ranch Riding
6. Sr. Mule Working Cow Mule
7. Sr. Mule Cutting
8. Sr. Mule English Pleasure
9. Sr. Mule Hunter Under Saddle
10. Sr. Mule Saddle Seat Pleasure
11. Sr. Mule Dressage
12. Sr. Mule Hunter Hack
13. Sr. Mule Working Hunter
14. Sr. Mule Jumping

### **C. JUNIOR MULE PERFORMANCE CLASSES**

1. Jr. Mule Western Pleasure
2. Jr. Mule Trail
3. Jr. Mule Reining
4. Jr. Mule Western Riding
5. Jr. Mule Ranch Riding
6. Jr. Mule Working Cow Mule
7. Jr. Mule Cutting
8. Jr. Mule English Pleasure
9. Jr. Mule Hunter Under Saddle
10. Jr. Mule Saddle Seat Pleasure
11. Jr. Mule Dressage
12. Jr. Mule Hunter Hack
13. Jr. Mule Working Hunter

### **D. AMATEUR PERFORMANCE CLASSES**

These classes may also be offered for Novice Amateur and Silver Amateurs.

1. Amateur Mule Showmanship at Halter
2. Amateur Mulemanship
3. *Amateur Reinsmanship*
4. Amateur Mule Western Pleasure
5. Amateur Mule Trail
6. Amateur Mule Reining
7. Amateur Mule Western Riding

8. Amateur Mule Ranch Riding
9. Amateur Mule Working Cow Mule
10. Amateur Mule Cutting
11. Amateur Mule English Pleasure
12. Amateur Mule Hunter Under Saddle
13. Amateur Mule Saddle Seat Pleasure
14. Amateur Mule Dressage
15. Amateur Mule Hunter Hack
16. Amateur Mule Working Hunter
17. Amateur Mule Jumping
18. Any Amateur Mule Driving
19. Any Amateur Mule Speed Event
20. Amateur Mule Halter
21. Amateur Mule Equitation

#### **E. YOUTH CLASSES**

1. Youth Mule Showmanship at Halter
2. Youth Mulemanship
3. *Youth Reinsmanship*
4. Youth Mule Western Pleasure
5. Youth Mule Trail
6. Youth Mule Reining
7. Youth Mule Western Riding
8. Youth Mule Ranch Riding
9. Youth Mule Working Cow Mule
10. Youth Mule Cutting
11. Youth Mule English Pleasure
12. Youth Mule Hunter Under Saddle
13. Youth Mule Saddle Seat Pleasure
14. Youth Mule Dressage
15. Youth Mule Hunter Hack
16. Youth Mule Working Hunter
17. Youth Mule Jumping
18. Any Youth Mule Driving
19. Any Youth Mule Speed Event
20. Youth Mule Equitation
21. Youth Mule Halter

#### **F. DRIVING CLASSES**

1. Pleasure Driving: Working-single mule
2. Pleasure Driving: Turnout – single mule
3. Obstacle Driving – single mule
4. Gambler's Choice – single mule
5. Double Jeopardy– single mule
6. Mule Drive & Ride – single mule
7. Heritage Driving/Antique Vehicle – single mule
8. Concourse D'Elegance – single mule

#### **G. GYMKHANA or SPEED EVENTS**

1. Mule Cloverleaf Barrel Race
2. Mule Pole Bending
3. Mule Keyhole Race
4. Mule Pylon Alley
5. Mule Hurdle Race
6. Mule Flag Race

#### **H. SPECIALTY CLASSES**

1. Coon Jumping Mule
2. Costume class
3. Freestyle Reining
4. Side Saddle Mule
5. Open Mule Walk/Trot

#### **I. MULE CATTLE CLASSES**

1. Mule Team Penning
2. Mule Ribbon Roping
3. Mule Steer Stopping
4. Mule Team Roping
5. Mule Steer Daubing

6. Working Cow Mule
7. Mule Calf Roping
8. Mule Cutting
9. *Team Sorting*

#### **J. MULE GAITED CLASSES**

1. 4 years old & under Walking Mule
2. 5 years & over Walking Mule
3. Style Racking Mule
4. Speed Racking Mule
5. Racking Mule
6. Gaited Mule Western Trail Pleasure
7. Gaited Mule English Trail Pleasure
8. Gaited Mulemanship
9. Gaited Mules at Halter

#### **K. DONKEY CLASSES**

1. Mammoth Jacks at Halter 56.01" & over
2. Standard Jacks at Halter 48.01" – 56"
3. Mammoth Jennets at Halter 54.01" & over
4. Standard Jennets at Halter 48.01" – 54"
5. Donkey Geldings Mammoth & Standard at Halter
6. Donkey Pleasure English
7. Donkey Pleasure Western
8. Donkey Obstacle Driving
9. Donkey Trail
10. Donkey Pleasure Driving
11. Donkey Snigging
12. Donkey Barrels
13. Donkey Poles
14. Donkey Keyhole
15. Reined Working Donkey
16. Donkey Dressage
17. Donkey Ranch Riding
18. Donkey Side Saddle
19. Donkey Hunter Hack
20. Any class from Amateur list # 4. designated Donkey
21. Any class from Youth # 5. designated Donkey
22. Training Level. Any of the performance classes listed in the Donkey Class List above specified as Training Level and limited to Walk/Trot.

**L. SPECIALLY APPROVED SHOWS** - Special approval may be obtained from NASMA on an individual basis for Team Pennings, Cuttings, and Reinings. In addition, special approval may be obtained for specialty shows, i.e. Gaited Shows, Driving Shows, Dressage, English. These will be individually approved by the committee based on information provided on the application form. In order to obtain approval a properly completed show application must be submitted in compliance with the rule book.

## **116 Single Judge Shows**

A single judge show is limited to one judge in the arena at any given time and held on one or more days.

## **117 Multiple Judge Shows**

**A.** Multiple judge shows must have each judge work independently with his or her own individual ring steward. There shall be no consultation or visiting between judges during the actual judging.

**B.** Multiple judge shows or consecutive day shows may in no way use the words "NASMA Championship" in their title or name of the show.

## 118 Points for NASMA Awards

NUMBER OF POINTS TO BE GIVEN						
# of NASMA Mules or Donkeys in class	1 <sup>st</sup>	2 <sup>nd</sup>	3 <sup>rd</sup>	4 <sup>th</sup>	5 <sup>th</sup>	6 <sup>th</sup>
1	0					
2	½					
3	1					
4 - 6	2	1				
7 - 9	3	2	1			
10 - 12	4	3	2	1		
13 - 15	5	4	3	2	1	
16 +	6	5	4	3	2	1

**A.** All animals must be registered with NASMA and the owner on record and exhibitor must be current NASMA members to earn NASMA points and awards.

1. Points given for Level "C" shows and contests are calculated using the above chart.
2. Points given for Level "B" shows are those for Level "C" shows multiplied by 2.
3. Points given for Level "A" shows are those for Level "C" shows multiplied by 3.

**B. Points for Grand and Reserve:** The Grand Champion Halter Mule or Donkey must receive one more point than any other mule or donkey in their division. The Reserve Champion must receive ½ point more than any mule or donkey in their sex division. Only 1 point or ½ point will be awarded for Grand or Reserve regardless of the level of show.

**C. Combining Classes:** Junior and Senior mule class may be combined into "Open Mule" to make a point class with the consent of all exhibitors in both age divisions.

**D.** Youth divisions 13 & under and 14 – 18 may be combined into "Youth Mule 18 & under to make a point class with the consent of all exhibitors in both age groups.

**E.** In any contest, points will be awarded on the basis of the total number of mules actually judged in each contest whether or not elimination is held.

**F.** No class with only one entry will receive points, but all classes, regardless of number of entries will be judged.

**G.** A NASMA member will have had to compete in at least one NASMA sanctioned show, competing in NASMA classes, within the year of the NASMA World Show for any points accrued at the NASMA World Show to count towards the NASMA year end High Point awards for that year.

**H.** Youth. A NASMA Youth member will have had to compete in at least one NASMA sanctioned show, competing in NASMA Youth classes, within the year of the NASMA World Show for any points accrued at the World show to count towards year end High Point Awards for that year."

## 119 Premium Lists and Prizes

**A.** Premium lists and entry forms should be printed in order to insure uniformity. All shows must abide by the entry fees listed on their premium.

**B. If money prizes are offered, the fixed amount of each prize shall be state in the premium list.** Special prizes do not have to appear on the premium list but is it recommended because it

enhances the attractiveness of the show or contest. The show committee is not required to award any existing un-won awards.

**C.** The premium list must contain a list of officers of the show or contest and the names of the NASMA officials. The exact location of the show must be specified and the date or dates to be held; also, the closing date of entries and the exact date and time of judging.

**D.** The premium list must clearly state those classes counting toward All-Around and High Point Awards.

## 120 Ribbons

**B.** Each class must be placed through the seventh mule, or whatever number is present if fewer than seven (7) (except that if a mule is disqualified, it is not to be placed even if there were fewer than seven (7) qualified mules in the class), even though ribbons are not given to all seven (7) mules. The following schedule of ribbons is recommended for all shows and contests:

1. First blue
2. Second red
3. Third yellow
4. Fourth white
5. Fifth pink
6. Sixth green
7. Seventh purple
8. Eighth brown
9. Ninth dark gray
10. Tenth light blue
11. Grand Champion purple
12. Reserve Champion purple/white

## 121 Show High Point Divisions

It is not mandatory that a NASMA show award High Point awards, but the divisions listed below are popular with many NASMA exhibitors across the country. These are suggested High Point divisions that can be used to meet the needs of specific regions of the country.

**A.** High Point Senior Mule

**B.** High Point Junior Mule

**C.** High Point Green Mule

**D.** High Point Youth Mule (May be divided into 13 & under and 14 – 18)

**E.** High Point Amateur Mule

**F.** *High Point Silver Amateur*

**G.** High Point Novice Amateur Mule

**H.** High Point Ten & Under (5-10 yr olds)

**I.** High Point Novice Youth Mule

**J.** High Point Open Donkey

**K.** High Point Gymkhana Mule

**L.** High Point Amateur Donkey

**M.** High Point Youth Donkey

**N.** Gaited Mule

\* At NASMA approved shows; an exhibitor must only be required to participate in classes outlined in this book in order to be eligible for any show High Point. Any classes popular in that region of the country, but not outlined in this rule book may be offered, but cannot count toward overall high point tabulations for that show or for NASMA points.

## 123 Point System for Tabulating Show High Points

**A.** It is not mandatory for an All-around Mule to be made at an approved show; however, if such an award is designated, the following scoring system shall be used to determine the winner.

**B.** Mules/donkeys placing in the top six of the class will be given a point for each mule placing below them plus one point not to exceed six points for first place.

- C. No points will be awarded to a disqualified mule.
- D. In case a tie occurs, the mule will be declared the All-Around who:
  1. earned points in the greatest number of classes, then;
  2. the mule winning over the greatest number of mules, then;
  3. earned the most points in performance events.

## 124 NASMA Titles and Awards

A. Disciplinary action can be taken against a member or non member who fraudulently advertises, claims or holds forth that this certain mule is entitled to any title or points awarded prior to the title or points being officially awarded or recorded by NASMA.

B. All classes outlined in the NASMA list of approved classes are to be counted toward year end titles, awards and high points with the exception of the following classes:

1. Freestyle Reining
2. Costume Class

C. The following Categories are established for NASMA Titles and Awards:

1. Halter Mule (see "NASMA Approved Class List")
2. Cattle Working Mule (see "NASMA Approved Class List")
3. Gymkhana Mule (see "NASMA Approved Class List")
4. English Mule
  - a. Hunter Under Saddle
  - b. Hunter Hack
  - c. Working Hunter
  - d. Jumping
5. Western Mule
  - a. Western Pleasure
  - b. Trail
  - c. Reining
  - d. Western Riding
  - e. Ranch Riding
  - f. Walk/Trot
6. Gaited Mule (see "NASMA Approved Class List")
7. Driving Mule (see "NASMA Approved Class List")

The same categories will be used for Donkey Champion awards but with Donkey specific classes only to be counted.

## 125 NASMA Register of Merit

A. The purpose of the Registers of Merit (ROM) is to establish a record of outstanding performance.

1. Halter Mule
2. Performance Mule
3. Youth Mule
4. Amateur Mule
5. Halter Donkey
6. Performance Donkey
7. Amateur Donkey
8. Youth Donkey

B. Qualification for one of the Registers of Merits can be only through approved and recognized events, and be owned by a NASMA member in good standing

C. Mules/Donkeys qualify for a Register of Merit when:

Halter Mule: They have won at least thirty (30) points in NASMA-approved Halter classes.

Performance Mule: They have won at least thirty (30) points in one or more events as outlined in the performance classes (categories 2-10 in 124 C)

Youth Mule or Youth Donkey: : They have won at least twenty points (20) in one or more events as outlined in the performance classes designated as "Youth" at an approved and recognized event.

Amateur Mule: They have won at least twenty points (20) in

one or more events as outlined in performance classes designated as Non Pro at an approved and recognized event.

**Halter Donkey:** They have won at least twenty (20) points in NASMA-approved Halter classes.

**Performance Donkey:** They have won at least twenty (20) points in one or more events as outlined in the performance classes (categories 2-10 in 124 C)

**D.** Points earned toward a Register of Merit may be accrued over the lifetime of the animal.

## **126 NASMA Superior Event Mule/Donkey**

**A.** The title "NASMA Superior Event Mule" will be awarded to any mule owned by a NASMA member in good standing provided said mule has earned one hundred (100) or more points in one NASMA recognized event at NASMA-approved contests.

**EXAMPLE:** A mule which earns a minimum of one hundred (100) in Western Pleasure will be designated as a NASMA Superior Event Mule in Western Pleasure.

**B.** A mule receives this title for each separate event in which it has earned one hundred (100) points

**C.** The Title "NASMA Superior Event Donkey" will be awarded to any donkey owned by a NASMA member in good standing provided said donkey has earned seventy (70) or more points in one NASMA recognized event at NASMA approved contests.

**D.** A donkey receives this title for each separate event in which it has earned seventy (70) points

**E.** Points earned toward a Superior award may be accrued over the lifetime of the animal.

## **127 NASMA Champion Mule/Donkey**

**A.** The title NASMA Champion is hereby from this date and in the future, reserved by the said Association for its express use and awarded to individual saddle mules which meet the requirements set out in the following section

**B.** This title is awarded to any mule owned by a NASMA member in good standing provided said mule has earned fifty (50) or more points in competition in official shows and contests recognized by NASMA provided:

1. That the points have been won in five (5) or more shows or contests and under five (5) or more different judges.
2. A minimum of five (5) of these points must be earned in halter classes.
3. A minimum of 45 points being earned in performance events and with a minimum of five (5) of those points having been earned in the Western Category.

**C.** When the title of NASMA champion is awarded, a proper certificate will be sent to the owner and proper notation will be made in the records of the Association.

## **128 NASMA Youth Champion Mule**

**A.** This title will be awarded to any youth exhibitor in good standing with NASMA Youth who, along with a single mule has earned fifty (50) or more Youth points in competition at NASMA shows and contests provided:

1. That the points have been won in five (5) or more shows or contests and under five (5) or more different judges.
2. A minimum of five (5) of these points must be earned in halter classes.
3. A minimum of 45 points being earned in performance events and with a minimum of five (5) of those points having been earned in the Western Category.

**B.** When the title of NASMA Youth Champion is awarded, a proper certificate will be sent to the owner and proper notation will

be made in the records of the Association.

C. Points earned toward NASMA Youth Champion award may be accrued over the lifetime of the animal.

## **129 NASMA Amateur Champion Mule**

A. This title will be awarded to any Amateur exhibitor in good standing with NASMA Amateur who, along with a single mule has earned fifty (50) or more Amateur points in competition at NASMA shows and contests provided:

1. That the points have been won in five (5) or more shows or contests and under five (5) or more different judges.
2. A minimum of five (5) of these points must be earned in halter classes.
3. A minimum of 45 points being earned in performance events and with a minimum of five (5) of those points having been earned in the Western Category.

B. When the title of NASMA Amateur Champion is awarded, a proper certificate will be sent to the owner and proper notation will be made in the records of the Association.

C. Points earned toward NASMA Amateur Champion award may be accrued over the lifetime of the animal.

## **130 NASMA Performance Versatility**

A. To earn this award, a mule of a NASMA member in good standing must have earned ten (10) points in 3 of the 7 Categories as found in 129. B 1-10.

B. Points earned toward Performance Versatility award may accrue over the lifetime of the animal.

### **NASMA HIGH POINT YEAR END AWARDS**

The top ten point earning animals in the following divisions will be recognized with year end titles at the culmination of each show season (January 1 through December 31). All points must be earned at NASMA sanctioned shows in NASMA approved events.

1. **High Point Jr. Mule:** Awarded to the mule age 5 and under, earning the most total points in the specified Junior mule or open classes including halter and performance events.
2. **High Point Sr. Mule:** Awarded to the mule age 6 and over, earning the most total points in the specified Senior mule or open classes including halter and performance events.
3. **High Point Saddle Mule at Halter:** Awarded to the mule earning the most points in halter class.
4. **High Point Western Mule:** Awarded to the mule earning the most total points in Western Category.
5. **High Point English Mule:** Awarded to the mule earning the most total points in English Category.
6. **High Point Gymkhana Mule:** Awarded to the mule earning the most total points in Gymkhana Category.
7. **High Point Driving Mule:** Awarded to the mule earning the most total points in Driving Category.
8. **High Point Cattle Working Mule:** Awarded to the mule earning the most total points in Cattle Category.
9. **High Point Gaited Mule:** Awarded to the mule earning the most points in the Gaited Category.
10. **High Point Amateur Mule:** Awarded to the mule, earning the most total points in all approved NASMA amateur events and calculated on one mule/one rider combination.
11. **High Point Youth Mule:** Awarded to the mule earning the most total points in all approved NASMA youth events and calculated on one mule/one rider combination. An animal may earn points with more than one exhibitor, but points will be calculated separately on each animal/rider combination. Walk trot classes will only count toward 10 and under points.
12. **High Point Youth Donkey:** Awarded to the donkey earning the most total points in all approved NASMA youth events and calculated on one mule/one rider combination. An

animal may earn points with more than one exhibitor, but points will be calculated separately on each animal/rider combination. Walk trot classes will only count toward 10 and under points.

**13. High Point Donkey:** Awarded to the donkey earning the most halter and performance points in classes designated as donkey classes.

**14. High Point Amateur Donkey:** Awarded to the donkey earning the most halter and performance points in classes designated as Amateur donkey classes.

**15. High Point Training Level Donkey:** Awarded to the donkey earning the most Training Level points in classes designated as Training Level Donkey. Training Level eligibility must be maintained for the entire Calendar Year.

**16. NASMA Leading Breeder Award:** This award will be presented annually to the individual who is listed in NASMA records as the breeder of the most mules earning NASMA points from January 1 to December 31 of the calendar year. Individual must be a NASMA member in good standing at the time the points were earned.

**17. NASMA Leading Jack Award:** This award will be presented annually to the NASMA registered jack whose get (both mules and donkeys) earn the most NASMA points at approved shows from January 1 to December 31 of that calendar year. More than one mule sired by the jack must earn points for the jack to be eligible for the award.

**18. *A Silver Amateur Certificate of Merit will be awarded to a year end Silver Amateur competitor with the highest earned points.***

## GENERAL SHOW RULES

### 131 Exhibitor Conduct

**A.** To promote competition in Association-approved events, in order that the Association's records will, at all time, reflect the actual quality of equine performance, any form of conduct which inhibits competition is expressly prohibited. This offense includes not only the person suggesting the prohibited conduct, but all who participate in the scheme or plan. Such conduct includes, but is not limited to:

1. Padding the classes by entering mule(s) not otherwise qualified for the competition, to fill a class to increase show points
2. Paying another's entry fees, directly or indirectly; or
3. Discouraging a potential competitor from entering a class.

**B.** Violation of this rule shall disqualify from participation in the event, both the mule entered by the person paying the fee and the mule entered by the recipient, and shall be referred by the show management to the Association for disciplinary action.

**C.** To assist the Association in the promotion of true competition, any person who is approached by another to cooperate in a scheme or plan to inhibit competition, shall immediately report the matter to the Association, failing which, the person approached may be subject to disciplinary action by the Executive Committee, the same as the person or persons suggesting the scheme or plan.

### 132 Inhumane Treatment

**A.** When an exhibitor, owner, and/or his representative acting on behalf of the exhibitor is guilty of unsportsmanlike conduct and/or inhumane treatment of a mule, horse, or donkey, NASMA can suspend the rights of such exhibitor, owner and/or his representative acting on behalf of the exhibitor to participate in future approved shows for such a period as judged appropriate.

**B.** No person on show grounds, including but not limited to, barns stalls, parking area and show arena, may treat a mule, donkey or horse in an inhumane manner, which includes, but is not limited to:

1. Placing an object in a animal's mouth so as to cause undue discomfort or distress;
2. Tying an animal in a manner as to cause undue discomfort or distress, or;
3. Letting blood from any equine
4. Using chemicals to sore or irritate skin on the mule
5. Using training paraphernalia on an animal that causes undue discomfort and distress
6. Engaging in any behavior that results in the presence of blood anywhere on the animal.

**C.** Upon discovery by any show official of inhumane treatment, show management shall immediately report the matter to the Association.

**D.** The standard by which conduct or treatment will be measured is that which a reasonable person informed and experienced in generally accepted equine training and exhibition procedures would determine to be cruel, abusive and inhumane. Gaited mules are subject to the jurisdiction of the acting DQP at that show.

### **133 Surgical Procedures**

**A.** Any surgical procedure or injection of any foreign substance or drug which could affect a mule's performance or alter its natural conformation or appearance is prohibited, except for those surgical procedures performed for the sole purpose of protecting the health of the mule. Upon discovery of the existence of prohibited surgery, show management should immediately report the matter to the Association.

1. Such surgical procedure or foreign substance injection shall be grounds for the Executive Committee or any appropriate committee of the Association to bar the mule from future participation in NASMA-approved events or shows for such a period of time as determined appropriate. Although ownership of the mule may thereafter be transferred to another party, the transfer of ownership will not dissolve or shorten the term of the ineligibility.

2. The exhibitor and owner are each responsible for a mule's condition and presumed to know all the rules and regulations of the Association, and the penalty provisions of these rules. Such individual's voluntary act of entering, exhibiting or causing to be exhibited a mule in an approved show makes him eligible for disciplinary sanctions, whether or not the owner or trainer had actual knowledge of the surgery, or directly authorized the surgical procedure or injection of foreign substance. Purchase and subsequent exhibition of a mule with such condition in approved show makes an individual responsible under this rule.

3. Every owner and exhibitor shall upon request of show management or Association representative, permit examination of a mule for determination of the presence of prohibited surgery and/or foreign substance injection and refusal of request shall immediately be reported to the Association.

4. Pending final hearing by the Executive Committee or such other appropriate hearing committee, the Executive Secretary may, by giving written notice of his action to the owner of record at his current address as shown on Association records, temporarily suspend a mule from further participation in the NASMA-approved event or show if preliminary examination indicates a violation of this rule.

### **134 Drugs and Medication**

**A.** If individual state drug requirements differ from those of NASMA, a copy of the State law should be submitted with

application for NASMA sanctioning. If there is a conflict between the NASMA rule and the local State's, the State's will take precedence. It is the responsibility of the exhibitor to be familiar with the State law concerning the use of drugs in equine exhibitions in that particular state.

**B.** No mule or donkey shall be shown in any class at a show recognized by the NASMA if the animal has been administered in any manner a prohibited substance which may affect the performance of a mule.

**C.** A prohibited substance is defined as any: stimulant, depressant, tranquilizer which could affect the performance of an animal. Any substance, regardless of how harmless or innocuous they might be, which may interfere with the detection of the aforementioned drugs is also considered a prohibited substance.

**D.** Conditionally permitted therapeutic medications are any drug, medication or substance which could affect the performance of an animal that is used for the legitimate treatment of illness or injury. These particular drugs/medications are forbidden unless all conditions of their administration are met.

**E.** Each of the following requirements is a condition to authorize administration of conditionally permitted therapeutic medications which shall be verified in a written medication report, signed by the attending veterinarian and filed with show management before exhibition of the animal.

1. Administration by a veterinarian who is a member of the AAEP and licensed to practice veterinary medicine in the state where the event is being held, or from a written prescription by a licensed veterinarian which documents that the administration of medication is necessary for the treatment of illness or injury. The administration of conditionally permitted therapeutic medication for the purpose of transport, grooming, training, etc is not therapeutic under this authorization rule.

2. Identification of the medication: the name, amount, strength and mode of administration.

3. Date and time of administration.

4. Identification of the horse: name, age, sex, color and entry number.

5. Diagnosis of illness/injury, reason for administration, and name of administering and/or prescribing AAEP veterinarian.

6. Signature of veterinarian or person administering the medication. If by prescription (written instructions), a copy must be attached to the medication report.

7. The medication report must be filed with show management within one hour after administration of the medication or one hour after show management is available, if administration occurs at a time other than during competition hours.

8. The medication report must be signed by show management and time of receipt report on the report.

9. While this report must be filed only if the administered medication will be present in amounts detectable in blood and/or urine samples at the time of competition/sampling, exhibitors are hereby cautioned it is their responsibility to determine whether or not such medication has had time to clear the horse's system. If there is any doubt, a medication report should be filed.

**F.** Only these eight (8) drugs listed below may be administered within 24 hours of showing and should be administered in accordance with the recommendation following each to ensure compliance with maximum allowable plasma levels.

1. Phenylbutazone - The maximum permitted plasma concentration of phenylbutazone is 15.0 micrograms per milliliter, and the maximum permitted trace level is 2.0 micrograms per milliliter. When phenylbutazone is

administered, the dose should be accurately calculated according to the actual weight of the animal. Each 24 hours, not more than 2.0 milligrams per pound of body weight should be administered, preferably less. For a 1,000 pound animal, the maximum daily dose is 2.0 grams, which equals two 1.0 gram tablets, or two 1.0 gram units of paste, or 10.0 cc of the injectable (200 milligrams per milliliter). Neither a total daily dose nor part of an injectable dose should be administered during the 12 hours prior to competing. In the event the phenylbutazone is administered orally, half of the maximum daily dose (1.0 gram per 1,000 lbs) can be administered each 12 hours during a five day treatment program. Phenylbutazone should not be used for more than five successive days.

**2. Flunixin** - The maximum permitted plasma concentration of Flunixin is 1.0 microgram per milliliter, and the maximum permitted trace level is 0.2 micrograms per milliliter. When Flunixin Meglumine (Banamine®) is administered, the dose should be accurately calculated according to the actual weight of the animal. Each 24 hours, not more than 0.5 milligrams per pound of body weight should be administered. For a 1,000 animal, the maximum daily dose is 500 milligrams, which equals two 250 milligram packets of granules, or one 500 milligram packet of granules, or 500 milligrams of the oral paste (available in 1,500 milligram dose syringes), or 10.0 cc of the injectable (50 milligrams per milliliter). No part of a dose should be administered during the twelve (12) hours prior to competing. Any medicated feed must be consumed and/or removed at least twelve (12) hours prior to competing. The medication should not be used for more than five successive days.

**3. Ketoprofen** - The maximum permitted plasma concentration of Ketoprofen is 40.0 nanograms per milliliter, and the maximum permitted trace level is 10.0 nanograms per milliliter. When Ketoprofen (Ketofen®) is administered, the dose should be accurately calculated according to the actual weight of the animal. Each 24 hours, not more than 1.0 milligram per pound of body weight should be administered. For a 1,000 pound animal, the maximum daily dose is 1.0 gram, which equals 10.0 cc of the injectable (100 milligrams per milliliter). No part of a dose should be administered during the twelve (12) hours prior to competing. The medication should not be used for more than five successive days.

**4. Meclofenamic Acid** - The maximum permitted plasma concentration of Meclofenamic Acid (Arquel®) is 2.5 micrograms per milliliter, and the maximum permitted trace level is 0.1 micrograms per milliliter. When Meclofenamic Acid is administered, the dose should be accurately calculated according to the actual weight of the animal. Each 12 hours, not more than 0.5 milligram per pound of body weight should be administered, preferably less. For a 1,000 pound animal, the maximum 12 hour dose is 0.5 gram, which equals one 500 milligram packet of granules. The medication should not be used for more than five successive days.

**5. Naproxen** - The maximum permitted plasma concentration of Naproxen is 40.0 micrograms per milliliter, and the maximum permitted trace level is 2.0 micrograms per milliliter. When Naproxen is administered, the dose should be accurately calculated according to the actual weight of the animal. Each 24 hours, not more than 4.0 milligrams per pound of body weight should be administered. For a 1,000 pound animal, the maximum daily dose is 4.0 grams, which equals eight 500 milligram tablets. No part of a dose should be administered during the twelve (12) hours prior to competing. Any medicated feed should be consumed and/or removed at

least twelve (12) hours prior to competing. The medication should not be used for more than five successive days.

**6.** Isoxsuprine - Each 24 hours, not more than 1.6 milligrams per pound of body weight should be administered (usually divided in two equal doses given 12 hours apart). For a 1,000 pound animal, the maximum daily dose is 1,600 milligrams, which equals 80 20-milligram tablets. No part of a dose should be administered during the four hours prior to competing. Any medicated feed should be consumed and/or removed at least four hours prior to competing.

**7.** Lidocaine/Mepivacaine - (when administered within 24 hours of showing) may only be used under actual observation of event management (or designated representative) and/or the official show veterinarian, either of which must sign the medication report form, to aid in the surgical repair of minor skin lacerations which, by their very nature, would not prevent the horse from competing following surgery.

**G.** Each of the eight medications listed above must be administered in accordance with the recommendations as given for each. Should the testing laboratory report the presence of one of these drugs in an amount greater than what would be consistent with the recommendation or at a level higher than the maximum permitted plasma analysis of the specimen take from the mule.

**H.** All owners, trainers and exhibitors are accountable for the condition of any mule which they enter or allow being entered, in any NASMA-sponsored or approved event. Such persons are hereafter referred to as "responsible parties.@ By voluntarily entering a mule in an NASMA-approved or sponsored event, the responsible parties are presumed to know all rules and regulations of the Association. Based on their accountability for their mule's condition, all responsible parties are subject to disciplinary action any time a prohibited substance is detected at a NASMA-approved or sponsored event, regardless of the reason the prohibited substance has been administered, and whether or not the responsible parties had actual knowledge of the administration or presence of the prohibited substance.

**I.** In addition the "responsible parties@ as that term is used in this rule, any person who administers, aids in the administration of any prohibited substance shall be subject to disciplinary action. Such persons are hereafter referred to as "involved parties.@

**J.** All drug test of NASMA-approved event will be done under the direction of the NASMA office or that of the show management of a particular show, unless the show is in a state that has established drug testing procedures. Those shows that are tested by NASMA will be selected at random by NASMA; however, the show management of any NASMA event can request that a show be tested if show management agrees to be responsible for the cost associated with the testing. Any drug testing performed at the request of the show management shall be conducted by NASMA designated representatives.

**K.** It shall be presumed that the sample of urine, saliva, blood or other substance tested by the laboratory to which it was sent is the one taken from the mule in question, that its integrity has been preserved, and that the procedures of the collection and preservation, transfer to the laboratory, analysis of the sample and report received from the laboratory pertaining to the horse in question are presumed to be accurate and correct reflections of the condition of the mule during the show in which the mule was entered. The burden shall be on the responsible or involved parties to rebut the aforesaid presumption in a hearing conducted by the Association's Executive Committee or its appointed committee

**L.** A request by a NASMA or show management representative or the State veterinarian to take a specimen of urine, saliva, blood or other substance for testing shall not be refused by any person.

Refusal to comply with such a request shall constitute grounds for immediate disqualification of the mule from further participation in the show and shall also be considered a positive drug test for purposes of this rule. Artificial induction of urination is at the option of the owner/agent.

**M.** Cooperation with the NASMA-approved or State veterinarian and/or his or her agents and/or Association representative shall include, but not be limited to:

1. Taking the animal immediately to the location selected by the appointed veterinarian and/or his or her agents for testing the mule and presents it for testing.
2. Assist the veterinarian and/or his or her agents in procuring the sample promptly, including, but not limited to, removing equipment from mule, leaving it quietly in the stall and avoiding distractions to it. Schooling, lengthy cooling or, bandaging and other delays of this type may be construed as non-cooperation.
3. Polite attitude and actions toward the veterinarian and/or his or her staff and/or Association representatives.
4. Failure to cooperate shall be considered a refusal.

**N.** Mules in competition at recognized shows are subject to examination by a licensed veterinarian or an Association representative who must be approved by NASMA. The examination may include positive identification, physical, saliva, urine, blood tests, or other test or procedures at the discretion of said licensed veterinarian necessary to effectuate the purposes of this rule. Said veterinarian may examine any or all mules in the class(es) in a show, or any mule entered in any class, whether in competition or not, or any mule scratched or withdrawn or which simply fails to appear for competition, by any other exhibitor within 24 hours prior to the class for which it has been entered. A mule which has been withdrawn from competition may be administered a prohibited substance provided the prohibited substance is declared to show management prior to a requested drug testing.

1. At such time as NASMA receives written notification of a positive drug test involving a forbidden substance, all "responsible parties" shall immediately be placed on temporary suspension and denied all privileges of the Association, pending hearing on the matter. The NASMA shall mail written notification of this action to the responsible parties and shall also give notification via telephone when possible. Any responsible party will be charged a \$200.00 restitution upon receipt of notice to NASMA of a positive drug test.

**O.** The animal involved, as well as the responsible or involved parties, may be subject to but not limited to, the following penalties where appropriate.

1. Barred from competition
2. Forfeit all awards, or monies, or points, or placings, thereby moving up mules placing behind the disqualified mules and possible redistribution of awards, or monies, or points or placings.
3. Although ownership of such mule may, thereafter, be transferred to another party, the transfer of ownership will not dissolve or shorten the terms of disciplinary action.
4. Penalties or fines
5. Suspension

## **135 Judges**

**A. Approved Judges:** Judges for approved NASMA classes must be selected from the current approved list of The North American Saddle Mule Association

**B.** Upon request, the office of the Executive Secretary of the NASMA will furnish a list of qualified and approved judges to organizations or persons sponsoring shows or contests

**C. Membership:** A judge must be a current member in good standing of the NASMA.

Any person suspended by the NASMA for cause, excepting by the automatic suspension rule for failure to pay dues and accounts, will be automatically removed from the list of approved judges and must reapply for approval in the usual manner.

**D. Qualifications:** Designation as an approved NASMA judge is a privilege only, not a right. Subject to Executive Committee review, this privilege may be bestowed by the Judges Committee of the NASMA. Subject only to Executive Committee review the Committee may give the designation or revoke the same in accordance with the procedures set up by this committee. The qualifications sought among others are:

1. equine expertise
2. personal character
3. interest in the Saddle Mule
4. interest in the exhibitors
5. hold a valid judging card in one or more of the following organizations
  - a. ADMS
  - b. AQHA
  - c. IBHA
  - d. AHSA
  - e. ApHA
  - f. PHBA
  - g. APHA
  - h. AAHA
  - i. any other horse breed associations

**E. Removal:** Removal of an individual from the Associations judge's list of approved judges for any reason, including, but not limited to, suspension from NASMA membership, denial of Association privileges, failure to comply with Association rules, or suspension in any or all horse breed associations to which he/she holds a judging card shall be absolute, with no provision for automatic reinstatement. Upon regaining eligibility for approved judge's status, the individual may apply for reinstatement after the expiration of one (1) year from the date his/her removal.

**F. Reviews:** A judge's approved status will remain valid and in effect, unless revoked, for a period of three (3) years. At the end of that period, the judge's approved status is subject to automatic review.

Reviews of judges shall consist of formal complaints. IEIS applicant testing scores, current IEIS re-certification requirements and NASMA judge's evaluation form comments from both show management and exhibitors. If a judge's review shows unsatisfactory scores, the judge may be subject to temporary probation, removal from the approved judges list, or any other action deemed appropriate by the NASMA judges committee until just cause is given to re-instate judging status.

**G. Guest Judge Card:** A NASMA guest judge's card may be issued on a per show basis to qualified or other breed carded judges hired only to judge specialty classes or divisions at NASMA shows. Approval must be obtained through the NASMA judges committee. No guest judge may officiate an entire NASMA show and may only guest judge three times in three years before being required to obtain a NASMA judging status.

**H. Complaints:** To make a formal complaint against a NASMA judge, such complaints must be in writing, signed by the complainant, contain alleged rule violations, date and locations within thirty (30) days of the show or contest. If a grievance is filed, the procedures outlined in disciplinary procedures would be followed.

**I. Treatment of Judges:** A NASMA judge will be treated with courtesy, cooperation and respect and no person, exhibitor, owner

or otherwise shall direct abuse or threatening conduct toward the judge, with in the furtherance of their judging duties or as a result , thereof, whether or not the conduct occurs during an approved event or show, or on show grounds.

**J.** No judge shall officiate two (2) consecutive times at the same show or contest.

**K.** A NASMA judge involved in the management of a show cannot officiate as a judge at that show.

**L. Attire:** Western attire, including long sleeves and pants and western hat and boots, is mandatory apparel for an individual to wear while judging an approved show or event. EXCEPTION: Where show circumstances are best served by alternative attire. English, Gaited, Driving and Dressage judges may, at their discretion, dress in attire other than Western appropriate for the classes they are judging.

**M. Conduct with Exhibitors:** After the judge has accepted a judging assignment, exhibitors shall not contact nor attempt to contact the judge pertaining to he/her judging of any mule at the show, Further, exhibitors shall not approach the judge for any reason prior to the completion of the judging.

**N.** No exhibitor will visit or socialize with the judge the day prior to or day of the contest.

**O.** Any request to speak to the judge must be made through the ring steward. When an exhibitor makes a request through the ring steward or other show official for the judge's opinion concerning that exhibitor's mule, it is urged the judge will give his opinion courteously and sincerely in the presence of the ring steward or other show official, however, there will be no fraternization between exhibitor and the judge during the show.

**P. Responsibilities:** A judge, upon arrival in a city in which he/she is to officiate should contact an official of the show or contest and advise him of his presence and location. A judge not showing up at the prescribed time without reasonable explanation may be suspended from judging for one year. After acceptance of a judging commitment, a judge shall endeavor, with all reasonable effort to judge the show and shall timely communicate to show managers any inability to do so, so as to allow the show manager maximum time in which to seek a suitable replacement. Additionally, the judge shall immediately file with the Association written explanation of such inability to meet his commitment.

**Q.** A judge shall not appear on the show or contest grounds prior to fifteen (15) minutes before judging. A judge shall not visit in the mule barns, nor with owners, nor inspect or discuss any mule entered in the show or contest before judging nor shall he review the judging program until after the judging has been completed.

**R.** A judge shall not attend a show, or exhibitor's party, or any other activity in the general location that is connected with a show on the day previous to the show at which is he is officiating. Exception: Multi breed shows, stock shows or fairs. A judge would be permitted on the show grounds prior to the NASMA show provided he was serving in a judging capacity for another organization or association.

**S. Conflict of Interest:** The judge and/or member of his/her immediate family shall not exhibit or act as agents or handlers of a mule at any approved mule show or contest at which he/she is officiating; nor may a mule that has been owned, trained, or conditioned within the previous six (6) months by the judge or members of his/her immediate family be exhibited in any approved mule show or contest at which he/she is officiating. If said persons are entered on one of these activities, the entry fee(s) shall be refunded and they shall not exhibit. A judge or person involved may be suspended for infraction of this rule.

**T.** A judge may order any person or mule from the competition for bad conduct of one or both.

**U. Equipment Check:** A judge shall disqualify an entry for attire and/or equipment prohibited or missing equipment required by NASMA rules. *A judge shall disqualify an entry for attire and/or equipment prohibited, or missing equipment required by NASMA rules. It is mandatory for judges to have bridles dropped in at least two classes per show except national and world championship shows where the champion and reserve champion in each performance class shall have bridles dropped.*

1. Any equipment specifically approved in the rules and the equipment has not been altered can not be disqualified by the judge.

2. The judge may prohibit the use of bits and equipment he/she may consider too severe.

3. A bit cannot be physically or mechanically changed to increase the severity of its use and may be eliminated at the discretion of the judge.

4. In all divisions, if a mule's mouth is found to be bloody, disqualification is at the discretion of the judge.

5. Whenever a snaffle bit or a hackamore is used on a Junior mule in western events (except roping, speed events and team penning) two hands must be used on the reins.

**V. Examination of Soundness:** The judge shall make an individual examination and check the action of all mules brought into the halter classes. This is essential, regardless of whether the completion indicated that it is necessary or not.

**W.** A judge shall have the authority to place a mule in whatever position in a class he thinks the merit of the mule justifies. His decision shall be final in all cases affecting the merits of the mules.

**X. Correction of Judge's Card: Once a class has been judged, it shall not be re-judged, and once the judge has marked his/her final record there shall be no changing.** A class is considered judged when the judge has marked his/her card and has submitted it to the ring steward. The correction of a judges card (due to miscalculations or omitted times or scores) does not constitute re-judging.

**Y.** It is recommended that the judge work no more than ten hours in one day. If the hours spent in judging are expected to run to an excessive length, the show should consider hiring two judges.

**Z. Judge's Evaluation Forms:** Judges Evaluation forms will be made available to all NASMA show managers and show exhibitors who are members in good standing of NASMA who are members in good standing of NASMA to comment on the performance of the judge officiating at each show. These comments may be wither positive or negative, and may cover over all attitude, knowledge of rules, familiarity with classes, professionalism and the ability to run an efficient show. All evaluation forms must be signed by the person making the comments and must include the signatory's printed full name, address and NASMA membership number. All judges evaluation forms will be placed confidentially in such judge's file and comments will be taken into consideration during future reviews.

## **136 Show Manager**

**A.** Any reputable person who can furnish proof that he is capable through ability or experience may act as show manager.

**B.** The show manager shall be the person in charge of the mule show.

**C.** The show manager shall have the sole authority to enforce all rules referring to the show or contest. He/she may excuse any mule or exhibitor from the show or contest prior to or during judging.

**D.** The show manager shall have the jurisdiction over preparing and mailing all entry blanks, premium lists and catalogs. He shall enforce the arrival and departure times as shown in the premium list or as advertised.

**E.** The show management shall not accept additional entries in a class once competition or judging for that class has begun.

**F.** The show manager must be present on the show grounds for the duration of the show. The show manager shall at all times extend every effort to satisfy the comfort of the mules, the exhibitors, the spectators and the officials. He/she shall be held responsible for maintenance of clean and orderly condition throughout the show and contest.

**G.** He shall make sure all obstacles, barriers, starting lines, markers, etc., are returned to their original position for each contestant so that conditions are identical for all contestants.

**H.** The show management shall receive written complaints from exhibitors, trainers, owners, show participants and other NASMA members of incidents of cruel, abusive or inhumane treatment of mules, donkeys or horses on the show grounds or any other complaints or incidents of rule violations and shall forward such complaints to the Association for possible disciplinary action under the Association's rules pertaining to unsportsmanlike conduct.

**I.** At the close of the show or contest, the show management shall retain original signed judge's placing cards, copy of the show results and entry cards. This information will be retained by the show management for at least two (2) years so that they will be available upon request by the NASMA

### **137 Show Secretary**

**A.** The show secretary shall be the primary person responsible for the correctness of the entries and show results, including verifying exhibitor and mule eligibility

**B.** It shall be the responsibility of the show secretary to maintain and record both entries and show results. The show secretary should submit the show results to the Association within ten (10) days of the date of the show. The show secretary shall keep a set or results on file for at least two (2) years from the date of the show. The show secretary shall be held responsible for the entry fees, office charges, etc., and for any fees collected for membership on behalf of NASMA. In addition, it is strongly recommended that any cash payments made to the show secretary for these fees be converted to a money order or check before being sent to NASMA.

### **138 Ring Steward**

**A.** A competent ring steward will be required at all approved shows for each judge. Any reputable person may act in the capacity of ring steward who can furnish proof that he/she is capable through ability or experience and is familiar with NASMA rules. The ring steward must be appropriately attired.

**B.** A good ring steward makes the work of the judge much easier by relieving the judge of unnecessary details. If the class is too large, the ring steward will inform the judge of the size of the incoming so the judge may divide the class if he/she wishes to do so. By assembling the class promptly, he/she will be able to keep the judging program on schedule and eliminate long delays between classes.

**C.** The ring steward will notify the judge when all mules are present for each class and call his/her attention those mules which are absent. This information will be placed on the record which the steward makes after each class has been judged.

**D.** The ring steward must have in mind that he/she has been selected to help the judge -- not advise them. Stewards shall carefully refrain from discussing or seeming to discuss the mules or the exhibitors with the judge. Stewards shall not take part, or seem to take part, in any of the judging. When the steward is not actively engaged in his/her duties, the steward shall place himself in such a position so as not to interfere with the judging and the view of the spectators. Steward must not allow the exhibitors to

crowd up in the ring or arena and should, at all times, endeavor to keep the possibilities of an accident at a minimum.

**E.** The ring steward has charge of the activity in the ring or the arena. Steward should act as mediator between the judge and the exhibitor. The judge should request the steward to move and place mules as he advises. When the ring or arena size is small and the class's entries are large, the steward should survey the situation and take every precaution to keep the mules moving until the judge is ready for them to be judged. Steward has the authority to ask an exhibitor to remove his/her mule for the safety of other mules or the spectators or remove an exhibitor for unsportsmanlike conduct.

**F.** The ring steward shall assist in arranging the class winners the same in every class. The public has the right to know how the various mules placed. (i.e. 1st. thru 7th. or 7th. thru 1st.)

**G.** When the judge has completed the judging of halter classes, then the steward shall call all first and second place class winners into the ring. Steward shall assemble the first place winners in one line and the second place class winners in another.

## **139 Veterinarian**

**A.** Any licensed veterinarian may officiate in the capacity of mule show veterinarian.

**B.** Health requirements should be outlined in the catalogs and on the entry blanks and enforced by the show management and veterinarian at the facilities where required

## **140 Age of Animal**

**A.** For the purpose of determining eligibility for competition, **the age of a mule shall be computed by the calendar year starting on January 1 of the year foaled.**

**B.** A mule is not eligible to participate in events approved by NASMA if its age as determined by examination of its teeth does not correspond to the age shown on its entry or registration, such determination by tooth examination to be made in accordance with the current Official Guide for Determining the Age of the Horse as adopted by the American Association of Equine Practitioners.

**1.** Every exhibitor-owner or trainer shall, upon request by a representative of NASMA, ring steward, judge, or the show management permits such examination to be made by a representative of NASMA and/or licensed veterinarian. Refusal to comply with such request shall constitute grounds for immediate disqualification of the mule from the NASMA events in progress and shall constitute grounds for suspension of Association membership.

**2.** Should such examination show the mules' age does not correspond to the foaling date on its entry or registration; such examination shall constitute removal of the mule from the event in progress.

## **141 Show Protest**

**A. The Grievance Committee shall have sole authority to investigate possible or alleged violations of any by law, rule or regulation of the Association.** The Grievance Committee will gather all needed information, the \$100.00 protest fee, and substantiate the need for further investigation, and then will transfer the documentation to the Board of Directors with no names mentioned. See 101 Standing Committees, 11.

**B.** The person filing the protest must be a NASMA member.

**C.** Violations concerning the following will NOT to be addressed by the Grievance Committee.

- 1.** Judge issues which are handled through the Judge's Committee
- 2.** Show ring lay out
- 3.** Timer problems
- 4.** Disagreements about disqualifications.

**D.** The protest must be filed in writing citing the specific rule infraction, signed by the protesting member(s) and delivered to any member of the Grievance Committee within 48 hours of the time of the cause of the protest.

**E.** The protest must be accompanied by a \$100.00 fee by cash or check which shall be forfeited if the protest is not sustained.

**F.** If the Grievance finds the Protest to be of merit, all points and awards earned at the show will be escrowed pending completion of the appeal process.

## **142 General Show Rules**

**A. Eligible Animals:** A NASMA show is open to all mules and standard/mammoth donkeys as defined in this By-Laws and Rules and Regulations.

**B. Splitting of classes:** At no time may mules and donkeys compete in the same class in any approved NASMA event, except in 10 & under Walk/Trot classes. Classes must be split into either mules or donkeys for all other classes.

**C. Miniatures:** No Miniature donkeys may be shown in any NASMA approved event.

**D. Zebra Hybrids:** No zebra hybrid (zorse, zedonk, etc.) may be shown in any NASMA approved event.

**E. Exhibitor entry fees, memberships:** A show must be open to all mule owners in good standing with the NASMA to gain approval. All show fees shall be the same to all exhibitors. EXCEPTION: Lower entries may be charged for entry into Youth classes and higher entries may be assigned to cattle classes and gaited classes. No exhibitor may be required to be a member of any organization in order to compete in an approved class. (except Amateur events where NASMA Amateur membership is required.) However, in order for NASMA points to be tabulated on an animal, the owner must be a current member of NASMA prior to the animal being shown.

**F. Entry Fees:** A recognized NASMA show must not require that an exhibitor enter or pay entry fees in any class to be eligible for another class. For example, a show or contest may not require entries in halter to show in performance classes or vice versa.

1. No person shall pay another exhibitor's fee for the purpose of enlarging an approved class nor shall any person accept payment of an entry fee for another to enlarge a particular class.

2. If premium money (payback) is provided, the show management must make full premium payments. The management cannot require a portion of the premium money to be added to any open sweepstakes or championship class. It shall be the option of the exhibitor to pay his fees for a championship or other sweepstakes event.

**G. Numbers:** Entry number must be assigned to the mules and not the exhibitor in NASMA-approved shows. Entry number must be worn in a visible position before the contestant may be placed in a class. It is mandatory that show management issue each mule one and only one number regardless of the number of classes entered or the number of exhibitors showing the mule. Furthermore, failure of the exhibitor to wear the correct number in a visible manner shall result in disqualification.

**H. Show Start Time:** An approved show will not be permitted to start earlier than the advertised time.

**I. Entry Errors:** The exhibitor is responsible for errors on the entry blank. It is up to the show management discretion as to whether a mule entered in the wrong class will be allowed to change classes.

**J. Cancellations:** The show management has the right to combine or cancel any class due to lack of entries, hazardous conditions, or acts of nature.

**K. Refunds:** Refunds will be at the discretion of the show

management.

**L. Gate Call:** All classes will be called three (3) times only. Class will close 2 minutes after the first animal enters the show arena. Consideration will be given only when a tack change is involved, in which case the exhibitor must inform the Gate Keeper upon leaving one class that time will be needed for a tack change before reentering for the next class. Once class is closed, the gate will be closed and remain closed until judging is complete.

**M. Single Entry:** If there is only one entry in a class, that entry must still compete and be judged. The judge may place a single entry in a position other than first place.

**N. Addressing Entries:** Show Management shall not announce the names of the mules or donkeys, owners and/or exhibitors prior to the judging of the class. All entries should be referred to by exhibitor number.

**O. Withdrawing:** Any contestant withdrawing from a contest after entering shall forfeit his entry fee and all Go-Around or Day money which may be accruing to him at the time of his withdrawal: except in the case of incapacitating sickness or injury to himself or his mule, or serious illness or death in the contestant's family, all prize monies won by him to that point in the contest shall be paid.

### **143 Performance General Rules**

**A. Jr. Mules:** Junior Mules may be shown in Senior classes only when Junior or Open classes are not offered in that event. Junior Mules entered in these classes may show in a snaffle or hackamore with the use of two hands or one handed in any legal shanked bit.

**B. Ties:** No contest is complete until all ties to seventh place have been worked off or settled by a flip of the coin.

**C. Fall of Rider:** Rider falling off animal during competition will be cause for disqualification. Exception: Working Cow Mule and Team Penning.

**D. Splitting Rail Classes:** If there are more than twenty entries in a class, the judge must divide the class into two or more goes.

**E. Hitting Forward of the Cinch:** Hitting or spurring a mule forward of the cinch in any approved performance event will result in disqualification.

**F. Number of Entries Per Exhibitor:** An exhibitor may exhibit a maximum of three mules or donkeys in any individual working event (i.e. Jumping, Working Hunter, Gymkhana events, Reining, Cattle events, Trail, Ranch riding, Western Riding, Obstacle Driving).

**G. Class Entry Restrictions:** There will be no cross entries between Gaited Trail Pleasure classes and Western Pleasure classes, i.e. entry in Walking Mule Trail Pleasure prevents entry in Western Pleasure Mule. Junior animal may not enter Senior animal classes in show where that same class is offered as a Junior class. A 10 & under exhibitor may not cross enter any other youth age division at the same show nor will he/she be allowed in any canter class at that show.

**H. Reruns:** Reruns shall not be allowed in any performance classes in the event of an exhibitor having equipment failure. Reruns shall be given in speed events because of timer failure or in roping events if the barrier malfunctions.

**I. Class Assembly:** All mules entered in a class to be judged must be assembled at the entrance to the arena in ample time for the judging to start promptly and to continue without delay, and shall remain there (except while competing) until dismissed by the judge, unless the judge shall otherwise direct.

**J. Equipment:** In any approved performance class the judge shall have the authority to require the removal or alteration of any pieces of equipment which, in his opinion, is unsafe would tend to give a mule or donkey an unfair advantage or which he believes is inhumane.

**K. Equipment Sores:** Any time a mule or donkey is ridden with a hackamore, snaffle or bit in any event and has an open, raw or bleeding sore as a result of the direct misuse of that hackamore, snaffle or bit, the animal must be disqualified. If any animal appears sullen, dull lethargic, emaciated, drawn or overly tired, the judge should consider disqualifying that animal at his discretion.

Anytime a mule or donkeys mouth is tied or fastened in a performance class, it shall be disqualified. (Exception: in Gymkhana and cattle events or with the use of a cavasson in English events.)

**L. Tail Carriage:** No mule shall be penalized for the manner in which he carries his tail nor for normal response with his tail to cues from his rider or when changing leads. A judge may, at his discretion, penalize a mule for excessive or exaggerated tail swishing or wringing of the tail or for a seemingly dead tail that merely dangles between the legs and does not show normal response.

**M. Go-Rounds:** If there is a cut or preliminary go-round, each mule or donkey must be ridden in the actual class by the same rider who rode in the cur or preliminary go-round.

**N.** All mules shall be ridden astride. **EXCEPTION:** Side Saddle Classes.

**O. Gaits During Reverse/lineup:** In performance classes judged on the rail animals will be called off the rail or reversed at any gait other than a walk, jog or trot.

**P. Arena Gates:** All gates to arena shall be closed during the running of every event. No gate shall be opened until the rider of riders has completed the course or class. Exception: When the judge has excused the exhibitor before the completion of the class.

**Q. Ground Conditions:** For the halter, showmanship, driving and pulling, the dirt condition should hard and packed. The surface should be dressed with drag to be sooth and lever. All other divisions, except gymkhana, should be lightly disced. Gymkhana should not be held until the arena has been disced.

**R. Futurities:** Approval may be obtained to hold Futurity classes in any event listed in the Gaited, Western and English Divisions.

## 144 Donkey General Rules

**A.** All class rules will be applied to donkeys with the following modifications:

**1. Showing with two hands:** In performance classed, donkeys may be ridden with two hands in any legal snaffle, bosal or shanked bit. Once an exhibitor has committed to riding one handed in an event, he/she shall not change to two handed riding or risk penalty at the discretion of the judge.

**2. Side Saddle:** In donkey side saddle classes, a lope or canter will be asked for at the judge's discretion.

**3. Youth:** No youth exhibitor may show an intact jack in any event at NASMA sanctions shows.

**4. Jack Halter Equipment:** In jack halter classes, the entrant must be allowed a second handler when control of the animal warrants. The second handler should not be judged as a detriment or have point deductions. Both handlers must remain at the head of the jack. Both handlers should have a chain lead clipped to the halter or stud bit. Both handlers must be adults. The ring steward or judge may excuse any jack that does not have the proper lead lines. Chains should be over or under the nose or through the mouth if warranted. Blood in the mouth is reason for dismissal from the class. Whips are not allowed.

**B.** Both Halter and Performance classes may be offered for all Standard/Mammoth donkeys or split into separate categories if desired by show management.

**C. Jackstock Classifications:** The following are NASMA recognized sizes for donkeys.

1. Mammoth Jack: 56.01" & up
2. Mammoth Jennet: 54.01" & up
3. Standard Jack: 48.01 – 56"
4. Standard Jennet 48.01" – 54"

## Halter and General Rules

No points, awards or titles will be added to the mule's record while shown as an unnamed animal.

**D.** The judge shall make an individual examination and check the action according to type of all mules brought into the halter class. This is essential, regardless of whether the competition indicated that it is necessary or not. The mule should not exhibit any physical unsoundness. If undesirable conformation traits are exhibited, the mule shall be penalized.

**E. Halter Class Routine:** All mules or donkeys must walk to the judge one at a time. As the animal approaches the judge will step to the right or to the left to enable the animal to trot straight to a cone placed 50 feet away. At the cone, the animal will continue trotting while turning to the left or the right, at the direction of the judge. After trotting, animals will be lined up head to tail for individual inspection by the judge. The judge shall inspect each animal from sides, front and rear. Exception: Gaited halter mule will do appropriate gait instead of trot.

### **F. Halter Class Divisions:**

**1. Halter classes divided by age:** These age divisions may be divided according to breed type, sex, or height at the discretion of the show management.

- a. Weanlings (foaled in the calendar year of the show)
- b. Yearlings (foaled in the calendar year of the year preceding the show)
- c. Two-Year-Old
- d. Three-Year-Old
- e. Four-Year-Old and Older

**2. Halter classes divided by breed type:** These are based on the breed of the dam of the mule and/or the purpose of the mule. There can be no cross entry between classes. (i.e. a mule cannot be entered in Gaited Type and Stock Type)

- a. **English Type** - dam to be of Thoroughbred, Warmblood, etc. breeding and/or the mule's conformation and way of going is suitable for English work under saddle.
- b. **Stock Type** - dam to be of stock horse breeding and/or the mule's conformation and way of going is suitable for Western Work under saddle.
- c. **Gaited Type** - dam to be of gaited horse breeding and/or the mule's conformation and way of going is suitable for gaited work under saddle. Mules entered in Gaited Halter classes must also be entered in at least one Gaited saddle class. **EXCEPTION:** Weanling, yearling and those mules too young to be started under saddle.

**3. Group halter classes:** The following classes are additional and are recommended if interest or entries justify them, but no points will be awarded.

- a. **Produce of Dam.** Two produce, either sex, any age can show. Dam need not be shown nor need produce be owned by owner of dam. Mare need not be present
- b. **Get of Sire:** Three get, either sex, any age can be shown. Sire need not be present nor need get be owned by owner of sire.

**(1) MARE AND FOAL:** Mare with one of her foals to be shown. Foal must have been foaled within the current calendar year. Mare and foal do not have to be owned by the same owner.

**(2) EXHIBITOR'S GROUP:** Group of four head, any age or sex, all owned by the exhibitor.

**4. Registered halter classes:** The mule or donkey is required to be registered with one of the following organizations specified on the class entry: NASMA, The American Donkey & Mule Society, the American Mule Association, the

American Council of Spotted Asses or the American Gaited Mule Association.

#### **G. Grand and Reserve Champions:**

1. When the judge has completed the judging of all halter classes in each division eligible for that particular Grand and Reserve, the ring steward shall call all first and second place winners into the ring. The ring steward shall assemble the first place winners in one line and the second place class winners in another for the judging of Grand & Reserve.

2. An overall Grand Champion will be chosen from the line of first place winners. The steward shall take the second place animal behind the Grand Champion and place it in line with the first place class winners to be judged equally for the title of Reserve Grand Champion. The Reserve Grand Champion will be chosen from the second place winner in the Grand Champion winner's class and the first place winners in other classes. All remaining second place animals are to be excused.

## **146 Mule & Donkey Class Divisions**

**All mule and donkey ages are measured from January 1 to December 31.** (i.e. A mule born in April 2000 will begin its yearling year on January 1, 2001, two-year-old year in January 2002 and so on.) Once a NASMA registered mule or donkey has been shown in a NASMA approved show, its age will not be changed on the registration papers for any reason, unless it is found to be older than originally mouthed or registered.

**1. JUNIOR MULE** - A mule five (5) years and younger as determined by mouthing by a licensed veterinarian. Junior mules may be mouthed at time of birth or any time thereafter to determine their eligibility for Junior classes. A veterinarian certificate (see Index) must be obtained at time of mouthing stating the date examination. A copy of that certificate must accompany any entry of that mule in classes designated as Junior Mule. A Junior Mule becomes ineligible for Junior classes on January 1 of his sixth year. (i.e. A mule mouthed 5 years old in July 4 of 2001 will be ineligible for competition in Junior Classes on January 1, 2002. As of January 1, 2002 that mule will be considered a Senior Mule.)

**a.** Two year old mules and donkeys may not be shown in any under saddle or driving class until after June 1 of their two year old year.

**b.** Junior Mules may be shown only in snaffle and hackamore and or a legal shanked bit cannot be shown in any training equipment. When shown Junior Mules may not be entered in a regular class if that same class is also offered as a Junior class.

**c.** Junior mules may not be entered in a senior class if that same class is also offered as Junior class.

**d.** Junior animals shown in regular classes not offered as Junior may be shown in a snaffle or hackamore with the use of two hands.

**e.** Any owner found to be falsely entering a Senior mule as a Junior mule is subject to disciplinary action and will forfeit all points earned in Junior.

**2. SENIOR MULE** is any mule six (6) years and older as determined by January 1 after its fifth birthday. Senior Mules must be shown with a regulation curb, half-breed, or spade bit with the use of one hand. **EXCEPTION:** Gaited mules. See Gaited Equipment.

**3. GREEN MULE** A mule of any age that is in the first two years of showing under saddle, Any mule, donkey or horse show in which the mule has shown under saddle shall count toward show experience. Competing in one show or more between January and December 31 of a calendar year counts

toward a full year of showing. The two years are consecutive and in the event the mule does not show, the second year, it is still counted toward Green Mule eligibility. A Green Mule must be shown with a legal snaffle or bosal/hackamore using two hands.

**4. DONKEY TRAINING LEVEL** Donkey Training Level Division is open to donkeys just beginning their performance career and have not advanced to a canter. Donkeys that have been shown in Open classes, or are currently being shown in Open classes cannot be shown in Training Level classes. A rider showing a donkey in this division can show other donkeys in other divisions.

**a.** Donkey Training Level Division classes will be limited to Walk/Trot classes. It is recommended that if show management offers a Training Level Division that at least 3 classes are included (i.e. Pleasure, Donkeymanship, and Trail). Show management can add other types of Training Level classes at their discretion. In regard to the expanded Training Level classes, a donkey cannot show in both Training Level and non-Training Level classes of the same type at a show (i.e. choose either Training Level English Equitation or English Equitation).

**b.** No donkey may be shown by more than one contestant in one event.

**c.** Any donkey showing in a Donkey Level Training class that advances to a non-Training Level class in a show which offers Training Level classes will forfeit their Training Level class status effective immediately. However, an animal CAN SHOW in non-Training Level classes, in a show which DOES NOT OFFER TRAINING LEVEL CLASSES, and still

**d.** A donkey showing in the Donkey Level Training Division may show in non-Training Level classes in any other division as long as cantering is not required (i.e. Driving, Showmanship, Halter).

**e.** Donkey Training Level Division End Of Year High Point award stipulations:

**1** To maintain eligibility for the end of year award, a donkey can not have been advanced to another division within the same calendar year. i.e. If a donkey is advanced to the Open, Youth, Amateur or Novice division, any points he may have accrued in that same year in the Training Level division are forfeit.

**2** He will however accrue points in whatever division he has been advanced to.

**f. TIME LIMIT** for participation in Donkey Training Level Division. Eligibility to remain in the Donkey Training Level Division will be determined on points accumulated in approved NASMA shows. The calendar year in which the donkey reaches 50 points, will be the final year that the donkey can compete in the Donkey Training Level Division. Once a donkey has reached 50 points he may continue to accrue points over 100 to complete the year in which he is competing. Once the final year of eligibility has ended, an exhibitor showing a Training Level donkey would then be required to either move the Training Level donkey into the Open division, or start a new donkey in the Training Level division.

## **5. FUTURITIES**

**1.** Approval may be obtained by the Show and Sanctioning Committee to hold futurity classes in Gaited, English and

Western Division. Mules and Donkeys are to be shown in separate classes.

**2.** Beginning in January of 2009, Futurity Mules/Donkeys must be out of Registered NASMA Jacks.

**3.** Stock Mules/Donkeys

**a.** Weanlings Futurity Mules/Donkeys

**(1)** Weanling Futurity Mules/Donkeys are those who are born in the year of the Futurity and must be under one year old as of December 31 of the year of the show (2 Accepted Classes).

**(2)** Accepted Classes

1. Weanling Futurity Halter - Mules

2. Weanling Futurity Halter - Donkeys

**b.** Yearling Futurity Mules/Donkeys (4 Accepted Classes)

**(1)** Yearling Futurity Mules/Donkeys must be one year old as of January 1 and under two years old as of December 31 of the year of the show.

**(2)** Accepted Classes

1. Yearling Futurity Halter – Mules

2. Yearling Futurity Halter – Donkeys

3. Yearling Futurity Longe Line walk/trot/jog-Mules

4. Yearling Futurity Longe Line walk/trot/jog-Donkeys

**c.** Two Year Old Futurity Mules/Donkeys (3 Accepted Classes)

**(1)** Two Year Old Futurity Mules/Donkeys must be two years old as of January 1 and under three years old as of December 31 of the year of the show (3 Accepted Classes).

**(2)** Accepted Classes

1. Two Year Old Futurity Halter – Mules

2. Two Year Old Futurity Halter - Donkeys

3. Two Year Old Futurity walk/trot under saddle -Mules

**d.** Three Year Old Futurity Mules/Donkeys (5 Accepted Classes)

**(1)** Three Year Old Futurity Mules/Donkeys must be three years old as of January 1 and under three years old as of December 31 of the year of the show.

**(2)** Three Year Old Futurity Mules/Donkeys must be shown in either a regulation snaffle or hackamore.

**(3)** Accepted Classes

1. Three Year Old Futurity Halter – Mules

2. Three Year Old Futurity Halter – Donkeys

3. Three Year Old Futurity Trail – Mules

4. Three Year Old Futurity Trail - Donkeys

5. Three Year Old Futurity Western Pleasure- Mule

**e.** Gaited Mules/Donkeys

Three Year Old Futurity Gaited Mules/Donkeys (4 Accepted Classes)

**(1)** Three Year Old Futurity Gaited Mules/Donkeys must be shown in either a regulation snaffle or gaited shanked bit.

**(2)** Accepted Classes

1. Three Year Old Futurity Gaited Halter – Mule

2. Three Year Old Futurity Gaited Halter – Donkey

3. Three Year Old Futurity Walk and Favorite Gait – Mule

4. Three Year Old Futurity Walk and Favorite Gait - Donkey

## **6. LONGE LINE**

The purpose of showing a yearling on longe line is to demonstrate that the mule/donkey has the movement, manners/expression/attitude, and conformation to become

competitive under saddle. Therefore, the purpose of this class is to reward:

- a. Quality of Movement,
- b. Manners/Expression/Attitude,
- c. Conformation suitable to future performance

And the mule/donkey should be judged with its suitability as a future performer under saddle in mind. This class should define what it means to be a “western pleasure prospect” or “hunter under saddle prospect.” Because these are yearling, they are not expected to demonstrate the behavior or quality of a finished show mule/donkey, but only that performance necessary for a reasonable presentation to the judge.

#### **A. Class Format**

The class format will consist of two parts: (1) a longeing demonstration lasting one and one-half minutes (90 seconds) and (2) a conformation inspection.

1. Show management is required to provide a five minute warm-up period for all exhibitors prior to class starting.
2. The use of a scribe for each judge is mandatory.
3. The longeing demonstration will begin at the sound of a whistle or other audible indicator when the mule/donkey has reached the perimeter of its circle. Time will not begin until the mule reaches this perimeter. When the “begin” signal is given, the exhibitor will be allowed 1 and ½ minutes (90 seconds) to present the mule/donkey at walk/trot/jog gaits in both directions. At the end of the 1 ½ minutes, the signal will be given to signify the end of the demonstration. Show management has the option of adding a “half-way” signal if they choose.
4. The conformation inspection will occur prior to the longeing demonstration. Each entry will be walked into the arena to the judge and pause for evaluation individually. They will then trot off straight and around a cone and take a place on the wall inside the arena. All entries will be inspected in this fashion and as the “trot-off” is administered, mule showing evidence of lameness should be excused from the class as that time. An example of the confirmation patten is illustrated in figure1 below.
5. It is recommended that longe line classes be shown in splits of no more than 15 mules at a time. Larger classes may also offer a finalists’ go-round before the class is placed.
6. Turnaround at the walk to take the second direction of the patten may be considered as fulfilling the walk requirements of the second direction portion of the scoring format.
7. It is recommended that all yearling Longe Line classes be held in a one go format only.

#### **B. Equipment**

Mules/Donkeys are to be shown in a halter. Either a regular or a show type halter is acceptable.

1. For the longeing demonstration, the only attachment allowed to the halter is the longe line. The longe line may not exceed 30 feet in length with a snap attached to the halter. The longe line must hang free from the halter without touching any part of the mule/donkey. It is permissible to use a longe whip, however disqualification will occur if the exhibitor blatantly strikes the mule/donkey with the whip to cause forward or lateral movement at any time during the longeing demonstration.

2. No other equipment is allowed on the mule/donkey during the class. Mechanical or retractable longe lines are allowed.
3. For the confirmation inspection, a lead shank, such as used in halter or showmanship classes may be exchanged for the longe line prior to the longeline demonstration.
4. Exhibitors are not to be penalized for using regular halter and plain longe lines, nor are they to be rewarded for using show halter and plain longe lines, nor are they to be rewarded for using show halters and show longe lines. Only movement, manners/expression/ way of going, and confirmation are being judged. The type of equipment used is not to be a consideration in placing the mule/donkey as long as the equipment meets the requirement stated above.

### C. Attire

Conventional Western attire is mandatory; except if a prospect is considered to be a Hunter prospect then conventional English attire is suggested. The type of attire worn by the exhibitor is not to be consideration in placing the mule/donkey as long as the attire meets the requirements stated above.

### D. Gaits

Gaits are to be judged according to the NASMA rules for Gaits for Western Pleasure and Hunter Under Saddle classes.

### E. Conformation & Equipment Inspection

Each mule/donkey is to be inspected by the judge on conformation, proper equipment and for evidence of abuse, inhumane treatment, or violation of NASAM rules. Mules/Donkeys will not be allowed to show in illegal equipment or if there is evidence of abuse, of inhumane treatment. It is mandatory that a “trot-off” be administered by the judge in the conformation portion of the class prior to longeing. Mules/Donkeys that show evidence of lameness will be excused prior to the longeing demonstration.

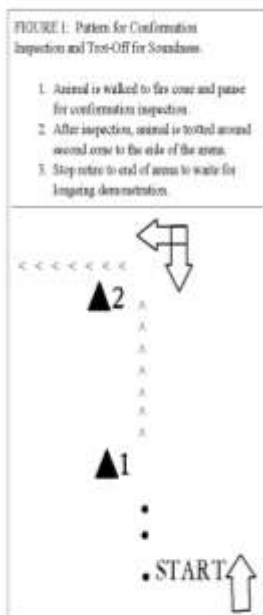

## **F. Judging**

- 1.** Judge(s) will be outside the longeing circle. The exhibitor will enter the arena and await the audible start signal. When the signal is given, the exhibitor will be allowed 1 ½ minutes (90 seconds) to present the mule/donkey. At the end of the 1 ½ minutes, a signal will be given again to signify the end of the demonstration. Show management has the option of adding a “half-way” signal if they choose. (The signal may be a bell, whistle or announcement.)
- 2.** The mule/donkey will be scored at walk/trot/jog gaits in both directions. Western Pleasure prospects are to show at the walk/ jog. Hunter Under Saddle prospect are to show at the walk/trot. Any mule/donkey that does not exhibit these gaits in each direction will be disqualified from the class  
Additionally, judges shall immediately excuse any mule/donkey who exhibits obvious lameness at any time during the class. (See scoring.) Exhibitors may begin work in the direction of their choice (counter or clockwise).
- 3.** At the end of the 1 1/2 minutes, the signal will be given and the exhibitor shall at the request of show management, retire from the longeing area to the far end of the ring. The mules/donkeys are to stand quietly on the wall while the other exhibitors present their mules/donkeys.
- 4.** The mules/donkeys are to be judged on movement (40 points), Manner/Expression/Attitude (10 points), conformation (20 points) suitable to their purpose and use of circle (3 points). Judges should judge the movement of the mule/donkey as defined in the NASMA rules for gaits.
- 5.** If the mule/donkey is playing on the longe line, it shall not count against the mule/donkey. The judge will, however, penalize the mule/donkey for excessive bucking, or running off, stumbling, or displaying attitudes that are uncomplimentary to pleasure mules/donkeys. Falling down will constitute disqualification. (See Scoring and Manners/Expression/Attitude Section G.4 Scoring below)
- 6.** Exhibitors are encouraged to exhibit their mule/donkey making full use of a 25’ radius circle, as they will be scored on this. (See Scoring).
- 7.** An exhibitor may only show one mule/donkey in each longe line class. The same exhibitor must show both segments of the class.
- 8.** The conformation inspection will occur as the mule/donkey is walked into the arena prior to the longeing demonstration at which the judge will evaluate the mule/donkey for conformation suitable for future under saddle performance. The judge may not discriminate for or against muscling, but rather look for a total picture, emphasizing balance, structural correctness, and athletic capability.

## **G. Scoring**

- 1.** The official NASMA Longe Line Scoring sheet must be used in each approved class by each judge. Use of a scribe for each judge is mandatory. The score sheet will be posted or a copy of the sheet will be posted at the end of the class. These sheets will be returned with the NASMA show results. The mules/donkey with the highest scores are the winners,

with a maximum possible total score of 73 and 36 being average. The judge(s) have the sole discretion to use their own personal preference to break any ties in total points.

**2.** NASMA requires that the score for each individual go be reflected on a component-by-component basis using a scribe and an approved NASMA score sheet. This score sheet represents the judge's report to an exhibitor of how a score was derived, and it is critical that this report to the exhibitor be accurate.

A. The show management is responsible for re-certifying all scores and totals. If errors in tabulation have occurred they should be immediately corrected and new placings announced at the event. Ultimately, the NASMA office will review all score sheets and be responsible for their accuracy in documentation of NASMA points and official paybacks.

B. One key element in accurately describing the scoring of the entire run to the exhibitor is the judge's scribe. It is the show management's responsibility to supply a scribe at each NASMA approved longe line event; however, it is the judge's responsibility to ensure that the scribe is trained prior to the first go of the day. The judge must confirm that the scribe understands the fundamentals of recording both gait scores and penalties. It is recommended that judges verify that the addition of the gait scores and penalties are correct at the completion of each go. As part of the training process for the scribe, the judge should make certain that his/her communications are clear to the scribe. To ensure this clear communication, the judge and scribe should agree upon a method of speaking, so that gait scores and penalty scores are not confused. (Example: A judge will say a number for a gait score and will say "penalty" and a number for a penalty, thus allowing the scribe to place the appropriate score in the appropriate box on the score sheet.) If for any reason a judge does not feel a scribe is competent, he/she should ask show management to replace the scribe immediately. Judges must sign every completed score sheet..

**3.** Movement will count for 40 points of the total score. Judges are to evaluate movement based on the gait descriptions found in NASMA #148 & #166.

A. **Walk.** The walk will be scored on a scale of 0-4 in each direction, with 2 being average. The mule/donkey must be walked long enough for the judge to have sufficient time to evaluate and score the walk. The change of direction turnaround at the walk may count for the second walk score on the official score sheet. Lower gait scores should reflect stumbling in the gait.

B. **Jog or Trot.** The jog/trot will be scored on a scale of 0-16 in each direction, with 8 being average. Using a 25' radius, the mule/donkey should jog or trot a minimum of ½ circle both direction of the ring. Lower gait scores should reflect stumbling in the gait.

C. **Use of Circle.** Scores for all gaits in both directions should reflect positive, consistent use of the 25' radius of the circle. Extra credit will be

given for full, extended use of the circle on a slightly loose line. Lower gait scores should reflect lack of full use of the circle.

**4. Manners/Expression/Attitude** will count for up to 10 points of the total score. The mule/donkey will be judged on manners, expression, and attitude on a scale of 0-10, with 5 being average. Mules/Donkeys will be penalized for obvious signs of overwork and sourness such as ear-pinning, head-throwing, striking, tail wringing, or a dull, lethargic manner of going. They will also be penalized for dangerous behavior such as excessive bucking, cutting into the circle, or funning off. Additionally, incidental touching the mule/donkey with the whip, cross-cantering, balking, backing up on the longe line and excessive urging from the exhibitor should be penalized accordingly.

**5. Confirmation** will count for up to 20 points of the total score. The mule/donkey will be judged on confirmation suitable to future performance as a Western Pleasure or Hunter Under Saddle competitor. The judges should look for a total picture, emphasizing balance, structural correctness, and athletic capability. Performance conformation will be judged on a scale of 0-20, with 10 being average.

**6. Use of the circle.** Consideration will be given to how well or how poorly the mule/donkey-exhibitor team uses the 25' radius of the longeing circle. A separate box on the scorecard is available to indicate an overall score (from 0-3 points) for use of the circle.

**Circle Scores:** As described earlier, NASMA has determined that a 25' radius is the appropriate size of circle in which to show a longe liner. It is the judge's responsibility to evaluate the circles and incorporate use of the circle in the gait scores based on the following scale.

**+3 points** (Good to Excellent Use of the Circle).

Mule/Donkey consistently stays on the perimeter of the circle with slight looseness in the line.

Mule/Donkey turns around on the circle perimeter

**+2 points** (Average use of the circle).

Mule/Donkey is only slightly inconsistent in using the 25' radius of the circle.

**+1 point** (Adequate use of the circle)

Mule/Donkey is shown in a circle radius of less than 25'.

**0 points** (General use of the circle)

Potentially dangerous slack in the line. Mule/Donkey pulls exhibitor out of the circle.

**7. Other scoring consideration:** This class should be looked upon as a class that defines what it means to be a "pleasure prospect" or "hunter prospect" suitable to become a future performer under saddle. Therefore, attitudes and attributes that contribute to becoming a future performer will be rewarded within the gait scores. Higher gait scores will reflect:

Above average to exceptional manners, expression, alertness, responsiveness and pleasant attitude,

Above average to exceptionally smooth transitions between gaits,

Above average to excellent cadence and consistency at walk/trot/jog gaits.

**8. Penalties and disqualifications.**

**A. Five (5) point penalties:**

- (1) Failure to demonstrate the jog or trot for an adequate distance to allow for proper evaluation of gait.

**B. Disqualification will occur in the following instances:**

- (1) Evidence of lameness – judge will immediately excuse mule/donkey from the arena.
- (2) Blatant striking mule/donkey with the whip during the longeing demonstration that will cause forward or lateral movement.
- (3) Mule/Donkey falls- A mule/donkey is considered to have fallen when it is on its side and all four legs are extended in the same direction.
- (4) Mule/Donkey steps over or becomes entangled in the longe line.
- (5) Violation of Equipment Section B above (improper equipment, evidence of abuse, or other violation of NASMA rules)
- (6) Failure to show at both gaits in both directions.
- (7) Loss of control of the mule/donkey to the point that the mule/donkey is loose in the arena
- (8) Exhibitor disrespect towards the judge(s).

**LCBOE LURE SCORE SHEET**

This class is to reward (1) Movement, (2) Manners: expression/attitude, and (3) Conformation. This class should define what it means to be a "pleasant propper" or "lure and propper". Score is based on 40 points Movement, 10 points Manners: expression/attitude, 20 points Conformation and 3 points Use of Circle with a total possible score of 73 points. The exhibitors are not expected to demonstrate behavior beyond that necessary for a reasonable presentation to list the judge. Bidding any playing on the longline is not to be penalized.

EXHIBITOR #	CONFORMATION Q28, Average = 10	WALK Q4, Average = 2	JOC/TROT Q18, Average = 8	WALK Q4, Average = 2	JOC/TROT Q10, Average = 8	NUMBERS D10, Average = 5	USE OF CIRCLE Q13	SUBTOTAL	PENALTY	TOTAL SCORE	PLACING

1. **MOVEMENT**
2. **MANNERS: EXPRESSION/ATTITUDE** is an overall evaluation of manners, expression, responsiveness, quietness, and pleasant attitude.
3. **CONFORMATION** evaluates the multi-gait structural suitability for future performance under saddle.
  - USE OF CIRCLE (25 POINTS/NUMBERS)**
  - **3 points** (Good to Excellent use of the circle)
    - Multi-Gaiter consistently stay on the perimeter of the circle with slight looseness in the line.
    - Multi-Gaiter turns around on the circle perimeter.
  - **2 points** (Average use of the circle)
    - Multi-Gaiter is only slightly inward from in using the 25' radius of the circle.
  - **1 point** (Adequate use of the circle)
    - Multi-Gaiter is shown in circle radius of less than 25'.
- 8 points** (General use of the circle)
  - Potentially dangerous slack in the line.
  - Multi-Gaiter pulls exhibitor out of the circle.



## 147 Rider/Exhibitor Divisions

**A. OPEN** classes are open to all Rider/Exhibitor Divisions.

**B. YOUTH** is defined as a rider who is eighteen years and younger on January 1 of the calendar year of the show. A Youth must be in control of the animal he/she is handling at all times. The judge should and will excuse any entry that is not in control of his/her mule. No youth may show a jack in any event.

Youth classes may be split:

1. 18 & under
2. 13 & under
3. 14-18
4. 10 & under walk/trot

**B. NOVICE YOUTH** is any rider eighteen years and under on January 1 of the calendar year of the show who is an inexperienced and untrained rider.

1. A Novice Youth rider is a rider who has not competed in riding/driving classes at a horse, mule or donkey show for more than two years.

2. A Novice Youth rider is a rider who has not earned more than 20 points in classes at approved NASMA shows. Halter points do not count toward Novice Youth eligibility

3. The limit for competing Novice Youth events is three years. Novice Youth exhibitors may show in any youth, open, Jr. or Sr. events and still maintain Novice Youth status.

### **C. TEN & UNDER YOUTH WALK/TROT**

1. This division is for youth exhibitors 10 years old and younger. Mules and donkeys may be exhibited together in 10 & Under classes only.

2. Once an exhibitor has been judged in any Ten and under Showmanship or Walk/Trot class, he/she cannot exhibit in any other youth division or cantering class for the duration of that show. (with the exception of halter classes.)

3. For safety purposes, it is mandatory that at least one adult (parent, guardian, trainer) be present in the arena during Walk/Trot Barrels.

4. It is recommend that at least one adult (parent, guardian, trainer) be present in the arena during any other Walk/Trot riding classes.

### **5. TEN & UNDER YOUTH WALK/TROT CLASSES THAT MAY OFFERED**

**a. Showmanship at Halter:** to be judged the same as Youth Showmanship.

**b. Walk/Trot Western Pleasure:** to be judged the same as Western Pleasure omitting the lope, extended gaits and dismounts

**c. Walk/Trot Western Mulemanship:** to be judges the same as Youth Western Mulemanship omitting the lope extended gaits and dismount.

**d. Walk/Trot Hunt Seat Equitation:** to be judged the same as Youth Hunter Under Saddle omitting the extended gaits, canter or hand gallop and it is required that the exhibitor wear appropriate head gear with a chin strap under chin.'

**e. Walk/Trot Hunt Seat Equitation:** to be judged the same as Youth Hunt Seat Equitation omitting the canter extended gaits hand gallop riding without irons and dismounting.

**f. Walk/Trot Barrels:** to be judged the same as barrels, except that cantering for more than three strides during the course of the pattern will result in disqualification.

**g. Walk/Trot Trail:** to be judged the same as trail class, with the exception that gaits between the obstacles be adjusted to take into consideration the size and ability of the younger exhibitors.



**AMATEUR** is any rider nineteen years old and older on January 1 of the calendar year of the show who is no longer eligible to show in NASMA Youth classes, and who has not shown, judged, trained or assisted in training a mule, donkey or horse for remuneration, either directly or indirectly, nor received compensation for instructing another person in riding, driving, training or showing a mule, donkey or horse in competition for the previous five calendar years.

6. An Amateur exhibitor may not show, train or assist in the training of a mule for which their spouse is accepting any form of remuneration, either directly or indirectly for training, assisting in the training or showing of said mules.

7. Premium money is not to be considered remuneration, but payment of entry fees, expenses, etc, by any person other than the contestant, or the contestant's father, mother, sister, brother; grandparent, legal guardian or spouse shall be constituted remuneration.

8. Any mule or donkey exhibited in Amateur events must be owned solely by the contestant or by the contestant's immediate family. Leased and co-owned (other than immediate family co-owners) mules are ineligible.

9. No mule may be shown by more than one Amateur contestant in one event.

*10. The Amateur Committee will forward complaints to the Grievance Committee which will preside over any formal hearing regarding a member's eligibility or discipline following the procedures set up for protecting the due process of all involved in the protest and, should it be determined the NASMA Amateur to be found in violation, the Grievance Committee will invoke one of the penalties outlined in the Amateur Division.*

#### **11. Amateur Guidelines – Membership**

a. NASMA amateur membership cards will be issued by NASMA only upon application and NASMA Amateur Committee approval of the applicant, which application shall be truthful in each and every detail. **No exhibitor may show in any approved NASMA Amateur event without possessing a current NASMA Amateur card.**

b. Application shall verify, in addition to other requirements contained in this rule book, that; the applicant has not shown, trained or assisted in training a horse/mule/donkey for remuneration, either directly or indirectly nor received compensation for instructing another person riding, driving training or showing a horse/mule/donkey for five years previous to application for NASMA Amateur membership.

c. Any mule or donkey being shown in NASMA Amateur events must be a NASMA registered animal and current copy of said registration papers must be shown at the time of entry. The exhibitor (or spouse, parent, child immediate family members) must be listed as the sole actual legal owner of the mule/donkey being shown. The exhibitor agrees to document such ownership through notarized bill of sale or any other

reasonable means requested by the NASMA Amateur committee, to determine actual legal ownership.

**12. Amateur Eligibility:** The application for NASMA Amateur membership must be true and correct in each detail. A false statement shall be grounds for disciplinary action under NASMA's disciplinary procedure, which includes suspension, fine and/or expulsion from membership and maintains eligibility, when he or she meets and maintains the following requirements.

- a. Is 19 years of age on or after January of the year of application and no longer eligible to compete in NASMA Youth Classes.
- b. Has not shown, judged, trained or assisted in training a horse/mule/donkey for remuneration, defined as monetary, either directly or indirectly.
- c. Has not received remuneration for instructing another person in riding, driving, training or showing a horse/mule/donkey for five calendar years previous to application for NASMA Amateur membership.
- d. Cannot be an instructor or clinician for any type of mule, donkey or horse related training showing, or judging clinic or seminar where any money is generated and received either directly or indirectly for five calendar years previous to application for NASMA Amateur membership.
- e. Does not hold credentials of horse/mule/donkey show judge, either for NASMA or any other equine organization.
- f. Cannot hold membership accreditation in a professional association for those events which are the same events or classes the individual competes or desires to compete in NASMA Amateur competition. (i.e. A person who competes in PRCA roping event may not compete in NASMA Amateur Calf roping, etc.)
- g. During the period of NASMA Amateur status he/she cannot exhibit in open or NASMA Amateur performance classes horse/mule/donkey owned by any third party (other than applicant, or the applicant's family which is the applicants spouse, child, stepchild, legal ward, father mother, stepparent, sister brother, grandparent or legal guardian.) "Owned" means, in addition to other legitimate methods of acquiring ownership, the bona fide legal ownership obtained for adequate consideration in reasonable relationship with the actual market value of the horse/mule donkey. Example: A \$5 payment for a World Championship quality mule/donkey does not meet the required character of required ownership for competition on NASMA's Amateur division. The relationship of the NASMA Amateur to the owner of the participating horse/mule/donkey must be evidence by submitting legal documentation (i.e. copies of marriage and/or birth certificate) to NASMA's Show committee.
- h. Has not, nor during the period of NASMA Amateur status cannot show a horse/mule/donkey for which the person's spouse has previously received remuneration for training during the 12 month period preceding the show of the horse/mule/donkey by the NASMA Amateur in NASMA Amateur or open competition.
- i. As condition of the issuance of NASMA Amateur membership, the applicant and/or the family member who actually owns the mule or donkey with which the NASMA Amateur will participate , agrees to proved

upon request a notarized bill of sale, registration papers or other proof as requested by NASMA to support the representation or sale economic ownership of the mule/donkey exhibited by the NASMA Amateur in NASMA Amateur open events and other criteria set forth above, This documentation will be kept on file at the NASMA office. Failure to promptly furnish such documentation upon request may be cause for immediate termination of NASMA Amateur membership and be grounds for possible disciplinary action by the Executive Committee under NASMA disciplinary procedure for failure to respond to requests for information.

- j.** Premium money is not prohibited remuneration, but payment of entry fees, or any expenses for the person or the mule/donkey with which.
- k.** Every person competing in a NASMA Amateur class must possess a current individual NASMA Amateur card. Show management must inspect this card at any show entered by requiring a copy be sent in with the entries or presented at time entry is made.
- l.** Upon revocation of NASMA Amateur membership because of ineligibility, all earned points from time of violation of eligibility shall be revoked.
- m.** A NASMA Amateur may not show a mule/donkey/horse owned by someone else in any performance event, regardless of who pays the entry fees.
- n.** Should the NASMA Amateur be found in violation of Amateur rules the penalties shall be as follows:
  - (1) First Violation:** a suspension from NASMA Amateur classes for period of one year from time of violation;
  - (2) Second Violation:** a suspension from NASMA Amateur classes for a period of two years from the time of violation;
  - (3) Third Violation:** a suspension of five years from time of violation.
- b.** It will not be considered a violation if an amateur assists in showing a Jack in a halter class when two handlers necessary or when showing a third party donkey or mule in halter classes. (Showmanship is not considered a halter class.)
- c. SPECIAL NOTE:** Amateur eligibility violation occurring prior to January 1, 2000 will not affect the forthcoming status of any Amateur exhibitor so long as all current guidelines are met and maintained.
- d. Novice Amateur Eligibility:**
  - (1)** Every person competing in a NASMA Novice Amateur class must possess a NASMA Novice Amateur membership card. Novice exhibitors may enter amateur, open, Junior or Senior classes while competing in Novice classes. Novice exhibitors, however, cannot have earned 10 or more performance points in the NASMA Open, NASMA Amateur or NASMA Youth divisions combined or their Novice eligibility will be relinquished. Applicants are responsible for verifying eligibility with NASMA; Halter points do not count against Novice eligibility.
  - (2)** Novice points are not recorded on a mule or donkey's performance record. Points are recorded on the exhibitor.
  - (3)** Once an individuals has earned 40 NASMA

Novice Amateur points, Novice Youth Points or any combination thereof, he or she will no longer be eligible to participate in Novice classes in subsequent years, but may continue to compete in Novice until the end of the calendar year in which the 40 Novice or 10 regular points were earned.

- (4) If an individual is considered a Novice upon application, he or she will be considered a Novice for that calendar year.
  - (5) Novice points earned may not be used for NASMA Amateur awards or World Championship Show qualifications. A Novice Certificate Of Merit will be awarded once an individual has earned 40 Novice points.
  - (6) Individuals earning 10 regular NASMA Amateur points will not receive a certificate (as these points were not earned in Novice), but must surrender the Novice membership at the end of their Novice year.
  - (7) A NASMA Novice Amateur is subject to all NASMA Amateur eligibility and membership requirements as listed in the Amateur Guidelines of this rule book.
- e. *SILVER AMATEURS (50 & OVER)*
- (1) *NASMA approved shows may offer any amateur performance class as a 50 and over class in addition to the regular amateur class.*
  - (2) *These classes are designed to provide competition for the more mature amateur exhibitors. These classes will be designated as the "Silver Amateurs" classes. An amateur may begin competing in the Silver Amateurs classes on the day that they turn 50 years of age. That amateur may also continue to show in the regular amateur classes.*
  - (3) *Silver amateur points earned cannot be used toward NASMA Amateur Awards or World Championship Show qualifying. A Silver Amateur Certificate of Merit will be awarded to a year end Silver Amateur competitor with the highest earned points.*
  - (4) *Further, these classes are to be reviewed at the end of the first year offered to consider the possibility of becoming a show high-point division.*

## **2. Amateur Committee:**

- a. The Amateur Committee is considered as a Standing Committee of NASMA and follows the guidelines for Standing Committees.
- b. As a Standing Committee, it will consist of not less than three NASMA members, at least one to be a carded NASMA judge and not more than one can be a NASMA Amateur card holder. Each member will be appointed by the President for not less than one year and not more than three years.
- c. The Amateur Committee will evaluate all applications and be responsible for issuing cards. A file must be maintained on each applicant and card holder.
- d. The Amateur Committee and the Executive Committee will preside over any formal hearing regarding a member's eligibility or discipline following the procedures set up for protecting the due process of all involved in the protest.

- e.** Decisions of these hearings must be completed and announced within one month. Extensions of this time frame may only be granted by the Executive Secretary based on a written request from either of the two committees or the individual member about whom the hearing is called. Results of such hearing will be forwarded to the Executive Secretary for enactment and publication.

## ENGLISH

### 148 General English Rules

**A. English Attire:** In all English classes, exhibitors and judges should bear in mind that at all times entries are being judged on ability rather than on personal attire. However, riders should wear hunt coats of traditional hunt seat style and conservative color, breeches or jodhpurs of traditional shades of buff, gray, khaki, canary or rust and high English boots or jodhpur shoes. Black, navy blue or brown hunting cap is mandatory. Youth exhibitors showing over fences or in any youth English class are required to wear a safety helmet with attached chin strap or harness... A tie or choker is required. Spurs of the un-rowelled type, crops or bats are optional. Hair must be neat and contained (as in net or braid). Judges must penalize contestants who do not conform. Judges, at their discretion, may authorize adjustments to attire due to weather related conditions.

**1. English Type Halter Attire:** Attire of the handler should permit free movement. Color may be chosen to compliment the animal, but should be conservative. Suitable recommended attire would be a collared polo shirt preferably white, vest, tie and gloves optional. Trousers should be loose enough to run in, jeans are forbidden. Running shoes or paddock boots required. English coat, breeches and boots are acceptable.

**B. English Bits:** In all English classes, an English snaffle, (no shank), Kimberwick, Pelham and/or full bridle (two reins), all with cavasson nose bands and plain leather brow bands, must be used. In reference to mouthpieces, nothing may protrude below the mouthpiece (bar). Solid and broken mouthpieces may have a port no higher than 12". On broken mouthpieces only, connecting rings of 13" or less in diameter or connecting flat bar of 3/8" to 3/4" (measured top to bottom with a maximum length of 2") and which lie flat in the mule's mouth are acceptable. All mouth pieces, must be a minimum of 5/16" in diameter - snaffles to be measured 1" in form the cheek or ring. Smooth round, slow twist, corkscrew, single twisted wire, double twisted wire mouthpieces and straight bar or solid mouthpieces with a maximum of 12" high ports are allowed. In jumping classes only, mechanical hackamores may be used.

**C. English Saddles and Equipment** Saddles must be black and/or brown colors and be of the hunting or forward seat type and may have in insert on the skirt. Saddle pads should fit size and shape of the saddle, except when necessary to accommodate numbers on both sides

**D. Optional English Equipment:**

1. Spurs of the un-rowelled type (except in dressage classes)
2. Crops or bats
3. Gloves
4. English breast plate
5. Braiding of mane and/or tail in hunt style

6. Standing or running martingales in working hunter and jumping only.

7. Boots or leg wraps in jumping only

#### E. Prohibited English Equipment

1. Draw reins

2. Rowelled spurs except in dressage

3. Leg wraps, figure 8 or flash cavasson except in jumping.

#### Acceptable English Bits For All Ages



Slow Twist



Corkscrew



Double Twisted Wire

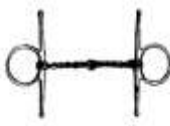

Single Twisted Wire



Correction Bit



Saddle Bit with  
Connecting Flat Bar

#### Unacceptable English Bits

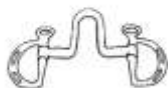

Excessive Port



Triangular Mouth

**F. ENGLISH TERMINOLOGY & Gaits:** The following terminology shall apply in all English classes whenever a specific gait is called for.

1. **WALK** is a natural, flat foot, four-beat gait. The mule must move straight and true at the walk. The walk must be alert, with a stride of reasonable length in keeping with the size of the mule. Loss of forward rhythmic motion shall be penalized.

2. **TROT** is a two-beat gait comprised of long, low, ground-covering, cadenced and balanced strides. Smoothness is more essential than speed. The knees should remain relatively flat, exhibiting minimal flexion. Excessive knee action will be penalized. Short quick strides and/or extreme speed will be penalized. When asked to extend the trot, there should be a definite lengthening of the stride.

3. **CANTER** is a three-beat gait; smooth, free moving, relaxed and straight on both leads. The stride should be long, low and ground covering. Over-collected four beat canter will be penalized. Excessive speed and slowness will be penalized.

4. **HAND GALLOP** should be a definite lengthening of the stride with a noticeable difference in speed. The mule should

be under control at all times, and be able to halt in a smooth, balanced manner.

## 149 English Pleasure

**A.** This class is open to astride riders in either Hunt Seat or Saddle Seat tack or attire. (See tack and attire requirements in both English and Gaited sections). It is open to both gaited and non-gaited animals.

**B. Class Routine:** The mules will be asked to demonstrate gaits both ways in the arena. Standard English gaits of Walk, Trot, Canter and Gallop will be asked for. If there are entries which are gaited, they will be asked for a favorite gait instead of a trot.

**C. Judging Considerations:** It is imperative that the mule give the distinct impression of being a pleasure to ride. To this end, all gaits must be performed with willingness and obvious ease, cadence, balance and smoothness. The mule should demonstrate style, presence and suitable conformation; prompt comfortable gaits. Easy ground covering action is desired. Manners and suitability as a Pleasure mount are paramount.

**D.** Gaited mules shown in English Pleasure must be flat shod with no artificial appliances.

## 150 Hunter Under Saddle

**A. Class Routine:** Hunters Under Saddle will be shown at the walk, trot and canter both ways in the arena to demonstrate their ability with both leads and transitions. At the option of the judge, animals may be asked to extend the walk, trot or hand gallop one or both ways of the arena. The judge may ask all or just the finalists to extend the walk or trot however, never more than eighth (8) animals may be asked to hand gallop at one time. At the hand gallop the judge may ask for the animals to halt and stand quietly on a loose rein. Animals are required to back easily and stand quietly either on the rail or in the line up. The reverse may be asked for at the walk or trot only and animals should be reversed to the inside of the arena.

**B. Judging Considerations:** Hunters Under Saddle should be suitable to purpose: they should move with long, low strides reaching forward with ease and smoothness, be able to lengthen stride and cover ground with relaxed, free flowing movement. Mules should be obedient, have a bright expression with alert ears, and should respond willingly to the rider with light leg and hand contact. Mules should be responsive and smooth in transition. When asked to extend the trot or hand gallop, they should move out with the same flowing motion. The poll should be level with, or slightly above, the withers to allow proper impulsion behind. The head position should be slightly in front of, or on, the vertical. This class will be judged on performance, condition and conformation. Maximum credit shall be given to the flowing, willing mule that shows quality movement while appearing to be fit, well trained and a pleasure to ride.

**C. Faults to be scored according to severity:**

1. Quick, short, or vertical strides
2. Being on the wrong lead
3. Rider posting on the wrong diagonal at the trot
4. Breaking gait
5. Excessive speed at any gait
6. Excessive slowness in any gait
7. Head and neck consistently carried too high
8. Head and neck consistently carried too low
9. Excessive nosing out
10. Carrying the nose behind the vertical
11. Failure of the rider to maintain light contact with the reins
12. Stumbling or falling
13. Consistently engaging in a four beat lope

**D. Faults which will be cause for disqualification**

1. Blatant disobedience such as bucking, rearing or bolting
2. Fall of animal or rider
3. Obvious lack of control or danger to other exhibitors
4. Being on the wrong lead for more than five strides

## 151 Hunter Hack

**A. Class Routine:** Mules are first required to jump two fences, two feet (2') to two feet six inches (2' 6") in height. In Junior Mule Hunter Hack or classes where Junior and Senior mules are combined, it is recommended that fences be set at two feet. Jumps do not have to be set on a line. However, if the jumps are set on a line they must be 36, 48, or 60 feet apart, or in increments of 12 feet, but no less than 36 feet. A ground line is required for each jump. Mules being considered for an award are then to be shown at a walk, trot and canter both ways in the arena. At the discretion of the judge, contestants may be asked to hand gallop, pull up and stand quietly following the last fence.

**B. Judging Considerations:** The class will be judged on flat work, manners, way of going, style over fences and even hunting pace. Hunter Hack entries should be suitable to purpose, showing quality movement in all three gaits with a bright expression and willingness to perform.

1. A schooling area must be provided with at least one practice jump. If it is impossible to supply a practice area, then each contestant must be allowed to practice a line and two jumps in the show arena just prior to the start of the class.
2. Placing for the class shall be determined by allowing 70 percent of the total score based on quality over fences and a maximum of 30 percent for work on the flat. It is recommended that judges give the final scoring to the show management for posting.
3. Faults over fences will be scored as in Working Hunter Class.
4. Faults during rail work to be scored the same as in a Hunter Under Saddle class

## 152 Working Hunter

**A.** A hunter course shall be any course which management deems a fair test of a hunter, but judges are responsible for correctness of each course after it has been set and shall call the show committee's attention to any errors that would tend to result in unfair or inappropriate courses. This is not a timed event.

**B.** A course or arena arrangement:

1. A minimum of 4 obstacles. Mules to jump a minimum of 8 fences. One change in direction is mandatory.
2. Types of obstacle which may be used.
  - a. Fences shall simulate obstacle found in the hunting field, such as natural look post and rail, brush, walls, coops and ascend oxer (not square). Triple bar and hogsback are prohibited. Striped poles are not recommended.
  - b. The top element of all fences must be securely placed so that a slight rub will not cause a knockdown;
  - c. Distance between fences is recommended to be 12 foot increments with the exception of some combinations: 1 stride in and out, 24 to 26 feet; 2 strides in and out, 36 feet; 4 strides 48 feet.
  - d. Height for Junior Mules, Novice and Youth to be 2 ft. and Open and Non Pro 2 ft. 6 inches to 2 ft. 9 inches.
  - e. A variation of 3 inches in fence height, down from the official heights listed, may be instituted if show management and official judges feel circumstances warrant, i.e. weather, footing, etc.
  - f. The use of wings on obstacles in hunter classes is recommended.

- g. Jump standards with hole heights at 3 inch intervals with jump cups are recommended.

### **C. Judging Considerations and Scoring**

To be judged on manners and way of going and style of jumping. Mules shall be credited which maintain an even hunting pace that covers the course with free-flowing strides. Preference will be shown to the mules with correct jumping style that meet fences squarely, jumping at the center of fence. Judges shall penalize unsafe jumping and bad form over fences, whether touch or untouched, including twisting. Incorrect leads around the ends of the course or cross-cantering shall be penalized, as well as excessive use of the crop. In and outs (one or two strides) shall be taken in the correct number of strides or be penalized. Any error which endangers the mule and/or rider, particularly refusals or knockdowns, shall be heavily penalized. Scoring shall be on a basis of 0-100, with an approximate breakdown as follows:

1. 90-100 - an excellent performer and good mover that jumps the entire course with cadence and balance and style
2. 80-89 - a good performer that jumps all fences reasonable well; an excellent performer that commits one or two minor faults
3. 70-79 - the average, fair mover that makes no serious faults, but lacks the style, cadence and good balance of the other mules; the good performer that make a few minor faults.
4. 60-69 - poor movers that make minor mistakes; fair or average mover that have one or two poor fences but no major faults of disobedience.
5. 50-59 - a mule that commits one major fault, such as hind knockdown, refusal, trot, cross canter or drops a leg.
6. 30-49 - a mule that commits two or more major faults, including front knockdowns and refusals, or jumps in a manner that otherwise endangers the mule and/or rider.
7. 0-29 - a mule that avoids elimination, but jumps in such an unsafe and dangerous manner as to preclude a higher score.

### **D. Disobediences:**

1. Refusal: When a mule stops in front of an obstacle (weather or not the obstacle is knocked down or altered) it is a refusal unless the animal immediately jumps the obstacle without backing one step. If the mule takes one step backward it is a refusal.
2. Run-out: A run-out occurs when the mule evades or passes the obstacle to be jumped, jumps an obstacle outside its limiting markings, or when the mule or rider knock down a flag, standard, wing or other element limiting the obstacle without the obstacle being jumped.
3. Loss of forward motion: Failure to maintain trot, canter or gallop after crossing starting line, except when it is a refusal.
4. Unnecessary circling on course: Any form of circle or circles, whereby the mule crosses its original track between
5. two consecutive obstacles anywhere on course, except to retake obstacle after refusal or run-out.
  - a. 1<sup>st</sup> disobedience anywhere on course – 3 faults.
  - b. 2<sup>nd</sup> disobedience anywhere on course - 6 faults
  - c. 3<sup>rd</sup> cumulative disobedience anywhere on course – elimination

### **E. Elimination**

1. A total of three disobediences which can include any of the following: refusal, stop, run out or extra circle.
2. Jumping an obstacle before it is reset
3. Bolting from the arena
4. Deliberately addressing an obstacle
5. Off Course.

### **F. General Rules:**

1. Circling once upon entering the ring and once upon leaving is permissible.
2. After jumping the fence and prior to leaving the arena, the mule shall trot a small circle on a loose rein for soundness.
3. Mules shall not be requested to re-jump the course
4. Manners shall be emphasized in Youth and Amateur classes.
5. When an obstacle is composed of several elements, any disturbance of these elements will be penalized; however, only a reduction in height of the top element shall be considered a knockdown.
6. In cases of broken equipment, the rider may either continue without penalty, or stop and correct the difficulty and be penalized the same as any loss of forward motion.
7. When an obstacle requires two or more fences (in and out), faults committed at each obstacle are considered separately. In case of a refusal or runout at one element, entry may re-jump the previous elements.
8. The course must be posted at least one hour before scheduled time of class.
9. A schooling area must be provided with at least one practice jump. If it is impossible to supply a practice area, then each contestant must be allowed to practice a line and two jumps in the show arena just prior to the start of the class.
10. Schooling over obstacles in the ring or over any part of an outside course is permitted only at the time designated by the show committee.

## 153 Jumping

Jumpers are scored mathematically on a basis of touches, knockdowns and disobedience.

**A. Course Requirements:** The course shall be posted at least one hour before scheduled time of class and shall consist of a minimum of four (4) obstacles. ( In and Out to count as one obstacle) Mules will jump a minimum of eight (8) obstacles. A ground line on approach side of all jumps is mandatory.

1. Types of Obstacles to be used:
  - a. Post & Rail (at least two)
  - b. Chicken Coop
  - c. Stone Wall
  - d. Triple Bar
  - e. Brush Jump
  - f. In-and-Out
  - g. Spread Jump
2. Both a starting line at least 12 feet in front of the first obstacle and a finish line at least 24 feet beyond the last obstacle must be indicated by markers at each end of the lines. Animals must start and finish by passing between markers. Obstacles should be located at least 48 feet apart. further if arena permits.
3. Initial height of fences should be 3 feet. In case of ties after the first round, jumps may be raised three (3) inches, unless no mule has gone clean, in which case fences
4. are not to be raised. During the second go-around, the tied mules are to be timed and the winner will be decided on the time only, if faults are equal.

**B. General Rules:**

1. Circling once upon entering and once upon leaving ring is permissible.
2. When an obstacle is moved or altered, it must be reset to original position.
3. When a mule makes 2 or more faults at an obstacle, only the major fault counts. In the case of equal faults, only one will be counted except in the case of disobedience which counts in addition.

4. Faults in the In and Out are counted separately for each member obstacle. In the case of a refusal on an In and Out, the mule must return to the start of the In and Out sequence and re-jump the previous elements as well as jump the following elements.

5. In case of broken equipment, the rider may either continue without penalty or stop and correct the difficulty, in which case, he will be penalized 3 faults. In case of loss of stirrup, rider may either continue without penalty or be eliminated.

### **C. Scoring and Faults:**

1. **Knockdowns** of obstacle, standard or wing with any portion of mule, rider, or equipment, 4 faults.

#### **2. Disobediences**

a. Refusal: When a mule stops in front of an obstacle (whether or not the obstacle is knocked down or altered) it is a refusal unless the animal immediately jumps the obstacle without backing one step. If the mule takes one step backward it is a refusal.

b. Run-out: A run-out occurs when the mule evades or passes the obstacle to be jumped, jumps an obstacle outside its limiting markings, or when the mule or rider knock down a flag, standard, wing or other element limiting the obstacle without the obstacle being jumped.

c. Loss of forward motion: Failure to maintain trot, canter or hand gallop after crossing starting line, except when it is a refusal.

d. Unnecessary circling on course: Any form of circle or circles, whereby the mule crosses its original track between

(1) 1<sup>st</sup> disobedience anywhere on course – 3 faults.

(2) 2<sup>nd</sup> disobedience anywhere on course - 6 faults

(3) 3<sup>rd</sup> cumulative disobedience anywhere on course  
– elimination

#### **3. Elimination**

a. A total of three disobediences anywhere on the course

b. Failure to complete the course

c. Jumping an obstacle before it is reset

d. Off course

e. Rider and/or animal leaving the arena before finishing the course

f. Deliberately addressing an obstacle.

**D. Attire and Equipment:** English tack and attires is required. Standing or running martingales, flat or figure 8 nosebands, jumping hackamores, leg wraps and/or boots are optional.

## **DRIVING**

### **154 General Driving Rules**

**A.** Mules and donkeys shall be safely and securely harnessed to a vehicle while competing in driving events. Two people are allowed on the vehicle only when two or more animals are being driven or when the exhibitor is a youth. Any assistance by the second person will result in disqualification.

**B.** The Driver must be seated comfortably in the vehicle, appearing both relaxed and effective. Either the one or two handed method of driving is acceptable. Common to both methods, the elbows and arms should be close to the body with an allowing, but steady hand enabling a consistent feel with the mules and donkey's or donkey's mouth. Drivers should not be penalized or rewarded for using either style of driving.

**C.** Classes may be provided for single or double hitches.

**D. DRIVING TERMINOLOGY** and Gaits

1. WALK is a natural flat foot, four beat gait. The mules and donkeys should walk energetically, but calmly, with even and determined pace. Loss of forward rhythmic movement shall be penalized.

2. PARK GAIT OR TROT is a clear, but not excessive, increase in pace and lengthening of stride while remaining well balanced and showing appropriate later flexion on the turns. The steps should be as even as possible with the hind feet touching the ground in the foot prints of the fore feet. The degree of energy and impulsion displayed at the road gait denotes clearly the degree of suppleness and balance of the animal.

3. ROAD TROT is a clear, but not excessive, increase in pace and lengthening of stride while remaining well balanced and showing appropriate lateral flexion on turns. Light contact to be maintained. Excessive speed will penalized.

4. REIN BACK consists of the animal moving backward in an unhurried manner with the head flexed and straight, pushing the vehicle back evenly in a straight line, The driver should use quiet aids and light contact.

*5. REVERSE: Change of direction, accomplished by the mule or donkey circling off the rail or crossing the ring at a walk or trot. In single hitch, small classes at the discretion of the judge and/or show management, the reverse may be accomplished by circling off the rail to change direction. In multiple hitch and/or large classes, the reverse should be made on the diagonal at the direction of the ring steward.*

6. HALT is a complete, square top of animal and vehicle without veering or abruptness. At the halt, animals should stand attentive, motionless and straight with the weight evenly distributed over all four legs and be ready to move off at the slightest indication from the driver.

**E. Whip** An appropriate whip shall be carried at all times while driving. The thong on the whip must be long enough to reach the shoulder of the farthest mules and donkeys. A driver not in compliance will be disqualified...

**F. Outside Assistance Only** the driver may handle the reins, whip or brake during a competition. The penalty for non compliance is elimination.

1. No change of driver is permitted, except where specified by the class description.

2. Drivers outside assistance after the judging has begun will be disqualified at the judge's discretion unless that assistance has specifically been allowed.

**G. Driving Attire:**

1. Drivers should be dressed conservatively according to the style of present day, either Western or English is acceptable.

3. Ladies wearing a skirt should wear a lap apron.

4. A hat of choice, long sleeves and gloves are required.

**H. The Animal**

1. Mules and donkeys and donkeys and donkeys must be serviceably sound and must not show evidence of lameness, broken wind or impairment of vision.

2. If shod, the mules and donkeys must be suitably shod for driving. No extended hooves, heavy shoes or toe weights will be allowed. EXCEPTION: Gaited Mules and donkeys.

**I. Harness**

1. Bridles should fit snugly to prevent catching on the vehicle or other pieces of harness. A throatlatch and a noseband or cavasson is mandatory.

2. Black harness is considered appropriate for painted vehicles and natural wood vehicles having black trim.

3. Brown harness is considered appropriate with natural wood

finished vehicles trimmed in brown.

4. All metal furnishings should match and be secure.

5. Breast collars are appropriate with light vehicles.

6. Full Collars are suggested for heavy carriages.

7. A correctly fitting harness is essential for the comfort of the harness mules and donkeys. A wider saddle is suggested for two wheeled vehicles as more weight rests on the mules and donkey's back. Narrower saddles are more appropriate for four wheeled vehicles.

8. Martingales and overchecks are prohibited in obstacle classes. Failure to comply incurs elimination.

#### **J. Bits**

1. Snaffle bits and other types of traditional driving bits are allowed. Legal bits include:

a. Half cheek snaffle

b. Liverpool

c. Elbow Driving

d. Bradoon Overchecks

**K. Vehicle** Drivers should strive to present an appropriate turnout. Appropriate indicates the balance and pleasing appearance of the combination of mules and donkeys and vehicle. Factors determining the above include compatible size, type and width of the mules and donkeys and vehicle. The way of going of the mules and donkeys may also affect the overall appearance.

**L. Splitting Classes:** Large classes may be split at the discretion of the judge. Size of the arena and safety are the prime consideration. Maybe unless the ring is very large, classes of 14 entries or more ought to be split.

**M. Excessive Use of Voice:** Excessive use of voice, shouting or whistling to the mules and donkeys may be penalized at the judge's discretion. The driver should strive to control the mules and donkey's movement with a minimum of vocal aids. If necessary, it is permissible to talk to the mules and donkeys in a subdued tone of voice. Clucks for starting, "walk on", "trot" "Gee", "Haw" and "whoa" are the more accepted terms.

#### **N. Leaving the Arena:**

1. No entry may leave the arena after judging has begun without permission from the ring steward. EXCEPTION: In the event of an accident or equipment failure which requires either medical attention or repair, the turnout must leave the arena as soon as possible after notifying the ring steward.

2. If asked to leave the arena by the ring steward, the turnout must do so as soon as possible.

**O. Canter**ing Canter is NOT ALLOWED in driving classes unless stated in the class description. Canter in the shafts will be disqualification.

**P. Course Time Allotment** All obstacle courses should be accurately measured with a measuring wheel if possible. The time allowed is 2 minutes to complete course with 30 sec. warning to finish.

## **155 Pleasure Driving – Working**

**A. Class Routine:** *Mules and donkeys and donkeys and donkeys shall enter the arena to the right at a Park Trot. Mules and donkeys will be exhibited both directions in the arena at the Walk, Park Trot and Road Trot. In single hitch, small classes at the discretion of the judge and/or show management, the reverse may be accomplished by circling off the rail to change direction. In team (or pair) hitch and/or large classes, the reverse should be made across the diagonal length of the arena at the direction of the ring steward. Animals will be asked to reinback and may be asked to halt any time during the class.*

**B. Judging Considerations:** A pleasure driving class in which entries are judged primarily on the suitability of the mule to provide a pleasant drive. Animals should show quality gaits, alert

expressions, smooth transitions and good manners. Emphasis: 70% on performance, manners and way of going; 20 % on condition and fit of harness and vehicle; and 10 % on neatness of turnout.

**C. Extra Work:** Mules and donkeys may be asked to do a Figure 8.

**D.** For Gaited driving classes the gaits are replaced with “flat walk, running Walk” of Slow Rack and Fast Rack.

## 156 Pleasure Driving - Turnout

**A. Judging Considerations** A pleasure driving class in which entries is judged primarily on the performance and quality of each turnout. Emphasis is on: 40% on performance, manners and way of going; 30% on the condition, fit and appropriateness of harness and vehicle; 30% on turnout.

**B. Class Routine:** The mules and donkeys will be shown both ways of the arena at a Walk, Part Trot, and Road Trot. They will be asked to Halt and stand quietly and to Rein Back. Mules and donkeys may be asked to do a Figure 8.

**C.** For Gaited classes the gaits are replaced with "Flat Walk and Running Walking or Slow Rack and Fast Rack.@

## 157 Reinsmanship

A pleasure driving class in which entries are judged primarily on the ability and skill of the driver.

**A. Judging Considerations:** Emphasis on: 75% on handling of reins and whip, control, posture and overall turnout of driver and 25% on the condition of the harness and vehicle.

**B.** Mules and donkeys will be shown at a Walk, Part Trot and Road Trot both ways in the arena. Drivers will be required to execute a rein back and may be asked to do a Figure 8.

**C.** For Gaited classes the gaits are replaced with "Flat Walk and Running Walk or Slow Rack and Fast Rack.

## 158 Obstacle Driving

Obstacle Driving will be judged on performance of the mule through a prescribed set of obstacles. Tiedowns or overchecks are not allowed in Obstacle Driving and will be cause for disqualification.

**A. Judging Considerations:** The judge will assign a point value to each obstacle and points will be added to or subtracted from this score based on the mules and donkey’s performance through the obstacle.

1. Credit will be given to those mules and donkeys that negotiate, in a continuous motion, the obstacles cleanly, smoothly and alertly with style, in prompt response to the driver's cues. Excessive hesitation at an obstacle will be penalized.

2. Points may be added or subtracted from the mules and donkey’s total score on the obstacles based on its attitude, manners, style and way of going.

3. The mules and donkeys are judged on the ease with which they maneuver the obstacles. Knocking over an obstacle or part of an obstacle, breaking gait and disobedience are to be considered penalties.

**B. Class Routine:** Drivers must be allowed to walk the course prior to the start of a class and inspect each obstacle. While walking the course, drivers shall not alter, adjust or in any way move an obstacle or any part thereof. Should a competitor have any question regarding a specific obstacle, he/she should call it to the attention of the ring steward for clarification. Drivers are prohibited from driving, leading, or riding mules and donkeys and donkeys and donkeys or from allowing the mules and to be driven, lead or ridden on any course at any time prior to the competition. Non compliance will result in elimination.

1. The judge may ask the driver to rein back at the completion of the course. If, however, anyone exhibitor is asked to rein back, all exhibitors must be asked to back.

#### **C. Course Requirements:**

1. The course will include a minimum of six and a maximum of eight obstacles, selected from the list of obstacles.
2. Care must be exercised to avoid the setting up of any of these obstacles in a manner that may be hazardous to the mules and donkeys or driver.
3. The obstacle course must be outlined by the show manager and posted prior to the class for the information of the exhibitor and judge.
4. The course shall be designed to require each mules and donkeys to demonstrate walk, park trot, and road trot somewhere between the obstacles as part of the working course with enough space provided for the judge to evaluate the gaits.

#### **D. Mandatory Obstacles**

1. Back Through - shall consist of either two landscape timbers, poles or pylons set a minimum of ten feet apart, but adjusted properly for the larger vehicle widths.
2. Box or Garage - three rails are set a minimum of fifteen feet long are set in a three-sided box. The mules and donkeys must be driven up to the obstacle; side passed either direction, and then backed into the box until the vehicle tires touch the back pole. If poles are elevated, they cannot be over ten inches high.
3. Serpentine - a minimum of 3 pylons around which the mules and donkeys is driven in a serpentine fashion at a walk (pylons at least 15 feet apart) or park trot (pylons at least 20 feet apart).
4. Straight and Narrow - two parallel poles, one foot apart, and minimum of twenty-five (25) feet long and a maximum of fifty (50) feet long. Driver must keep one wheel between the poles for the entire length. May be taken at either a walk or a park trot only.

#### **E. Optional Obstacles**

1. Bridge - A simulated bridge of a width of at least ten feet. To be taken at a walk only.
2. Figure 8 - two barrels or cones, around which the exhibitor must make a Figure 8 in a forward motion. Walk obstacles to be a minimum of ten (10) feet apart and park trot obstacles to be a minimum of (20) feet apart.
3. L-Obstacles - Poles placed in an "L" shape at least 15 feet apart, through which the mules and donkeys is driven at a walk only. If the rails are elevated, the maximum height may not exceed ten (10) inches in the center. The side of the L shall not be less than twenty feet long. Width may be adjusted for wider vehicles.
4. Mailbox - The mailbox must be set on a stand of four feet minimum height. Exhibitor must open box, remove mail and show to judge, then replace mail in box.
5. Simulated Water - A plastic sheet or tarp secured to the ground so that it will not become affixed the mules and donkey's foot or the wheel of the vehicle when the mules and donkeys passes over it.
6. U - Turn - A three rail box of which the rails are a minimum of 25 long, with a pylon located in the center of the opening of the box. The driver is to enter the box, drive around the pylon and exit the other side of the pylon.

#### **F. Prohibited Obstacles**

1. Live animals and hides
2. Driver dismount

**G. Scoring:** A mules and donkeys with major faults

(knockdowns, refusals, etc.) on the course will not be placed ahead of a mules and donkeys that worked through the obstacles cleanly. A mules and donkeys should be penalized for touch of any elements of the course and for unnecessary delay in approaching the obstacles.

**1. Off Course**

- a. Deviating from the prescribed order in which the obstacles are to be approached.
- b. Taking the obstacle from the wrong direction
- c. Negotiating an obstacle from the wrong side.
- d. Skipping an obstacle unless directed by the judge.

**2. Disqualification**

- a. Driver receiving outside assistance,
- b. breaking into a canter,
- c. failure to carry a whip, use of an
- d. overcheck or tie down and
- e. equipment failure results in elimination.

## 159 Double Jeopardy

A timed obstacle course to be driven over a prescribed course, not to exceed twelve (12) obstacles. By an entry consisting of mules and donkeys, vehicle and two drivers. 8-10 obstacles are recommended as a course length, but the number can be adjusted.

**A. Class Routine:**

After passing the starting line, the first driver shall proceed through each obstacle to the designated finish line. At this point, the reins are passed to the second driver who must drive the course in reverse order.

**B. Judging Considerations:** Course Faults are scored as penalty seconds and are added to the driver's elapsed time. Placings are determined on a low total time basis. Ties for first will be decided by a drive-off, unless otherwise announced by the Show Management.

**C. 5 second penalties:**

1. Exceeding prescribed time - 5 seconds
2. Knocking over start or finish marker - 5 seconds
3. Knocking down or dislodging obstacle - 5 seconds
4. Break in gait (each time) - 5 seconds
5. Disobedience - 5 seconds

**D. Elimination**

1. Off Course – elimination
2. Outside Assistance – elimination
3. Failure to carry whip – elimination
4. Use of tie-down or overcheck – elimination
5. Equipment failure – elimination
6. Cantering – elimination

## 160 Gamblers Choice

A timed driving obstacle course of unnumbered obstacles each carrying a specific point value. Each driver has the same amount of time to negotiate as many obstacles as possible. Each obstacle is assigned a point value according to its degree of difficulty and each driver tries to amass as high a score as possible within the time allowed.

**A. Class Routine:** After passing through the starting line, the driver may drive through the obstacles, in any order, from any direction. Each obstacle may be driven twice, but not in succession. If driven a third time, no points will be awarded.

1. No obstacle may be re-driven once it has been disturbed.  
EXCEPTION: Obstacles which are designed to be knocked down.
2. A signal will sound at the end of the allowed time and the driver must then exit through the finish markers when the total time on the course will be recorded.
3. If the signal sound when the competitor is committed to an

obstacle, the competitor may complete the obstacle and receive the appropriate points, then proceed through the finish line for total time to be recorded. Whether or not the competitor was committed to the last obstacle at the signal, will be left up to the judge.

**B. Scoring:**

Placings will be determined on high score basis. Time will decide ties. If a tie occurs in both points and time, the winner will be decided by a drive off.

1. No points will be awarded to an incorrectly complete obstacle. If the obstacle is incorrectly driven, but not disturbed, it may be attempted again.

2. In this class the circling rule does not apply. If a mules and donkeys should refuse or run out of an obstacle without disturbing it, the driver may elect not to attempt it and may drive to another obstacle without penalty. The obstacle may be attempted later, and if correctly driven, the appropriate points will be recorded.

3. Canter will be a cause for elimination.

## 161 Drive and Ride

**A.** This class is for a single driving mules and donkeys shown in two concurrent sections. This class shows the ability of a mule or donkey to be both a pleasure to be driven as well as a pleasure to ride. One groom is allowed to assist the exhibitor un-harness trained and tack up. The animal is to be ridden and driven by the same person.

**B. Class Routine:**

*1. In Harness: To be shown first in harness to suitable pleasure two or four wheel driving vehicle, both ways of the arena at a walk, slow trot and strong trot. To stand quietly and rein back. Exhibitor will carry a saddle (English or Western) and bridle. A halter and halter shank may also be carried and utilized during the tacking up period. On the judge's command, exhibitor will un-harness and tack up. Once all exhibitors have tacked up and mounted, the grooms will remove the vehicles from the arena.*

2. Under Saddle: To be shown under saddle both ways of the arena at a walk, trot and canter. To stand quietly and rein back. In the case of the gaited animals under saddle, a walk and favorite gait will be called for. Western, Hunt and Saddle Seat tack is permissible.

**C. Judging Considerations:**

1. To be judged 50% on harness and 50% on saddle competition.

2. Removal of the bridle while mule is between the shafts is cause for elimination

## 162 Heritage Driving/Antique Vehicle

**A. Judging Considerations:** To be judged 50% on performance, 20% on apparel of driver and personal appointments, 15% on vehicle, and 15% on harness.

**B. Apparel** - The required costumes should be dated on the vintage of the vehicle, i.e. formal with a formal carriage and sporting with a sporting vehicle. The driver must wear a hat, gloves, lap robe or apron and carry a whip at all times.

**C. Vehicle** - The antique type vehicles should be sound and safe for driving, the wheels and spokes tight. The mules and donkeys should be suitable to the vehicle and there should be a pleasing balance between the two.

**D. Harness** - The harness should be in good repair, clean and fit properly. All metal furnishings should match, be secure, and polished.

## 163 Concourse D'Elegance

**A.** The word elegance is the essence of this competition. The winner will be the turnout that presents the most elegant effect (vehicle, harness, appointments of mules, donkeys, driver, passengers, groom, etc) Performance will not be judged unless it detracts from the elegance of the turnout.

**B.** Class Routine: Entrants will be shown both ways of the arena at the walk, park trot and road trot. Animals may be asked to halt, reinback and stand quietly.

## 164 Snigging (Log Dragging)

the Snigging class is a judged event consisting of a mule or donkey dragging a log between a series of obstacles. Classes can be established for singles or pairs and it is best that they be divided for different sized animals. Classes must be split for either mules or donkeys.

### **A. Judging Considerations:**

1. Hooking and unhooking is a part of the judging. The course must be set so the contestant can return the log to its original position, turned in the correct direction for the next contestant.
2. No header or assistant will be allowed. ANY ASSISTANCE results in disqualification.
3. Drivers are allowed to encourage their animal forward with voice commands or slapping of reins (but not excessively). No whips or use of ends of reins allowed. Failure to follow this rule will result in disqualification.
4. Driver may drive from either side, change sides as necessary or ride on top of log.
5. A penalty will be assessed each time an obstacle or course marker is either stepped on or over or disturbed in any way by the animal, the driver or the log. Tennis balls should be used on top of cones to indicate penalties.
6. Failure to follow pattern is a disqualification.

### **B. Course Set Up:**

Suggested distance between weaving cones is either 13 or 17 feet. Suggested distance between parallel obstacles (logs) is tree width plus 16 inches. (Note: it is important for management to provide single/double trees since different size "trees" will have advantage/disadvantage on a set course.) Adequate distance (minimum 13 feet) must be allowed for any end lines or side lines.

### **C. Show management provides:**

1. Logs - proportionate in length and weight to the majority of animals to be shown in a particular class or division. For a mixed class, one average sized log as in "b" below can be used for all. The following are suggested size logs for various sized animals. (Diameter measurement taken at large end):
  - a. Standard/Large Standard/Donkeys or Mules under 14 hands: 8 foot 4 inch log, 4 inch diameter
  - b. Mammoth Donkeys or Saddle Mules over 14 hands: 8 foot log, 6 inch diameter
  - c. Draft Mules: 8 foot log, 8 inch diameter
2. Chain loop: each log will be wrapped with a piece of chain to make a loop not to exceed 24 inches to which a single tree (double tree) can be hooked. Chain extends from the sides of log (V shaped) in such a manner that the log will not turn.
3. Single tree (double tree) with hooks and connector for log, per the following sizes:
  - a. Single tree for all Donkey and Mule classes: 32 inches.
  - b. Double tree for all sizes: 36 inches

### Sample Snigging Pattern

Overall Pattern Width: 85'

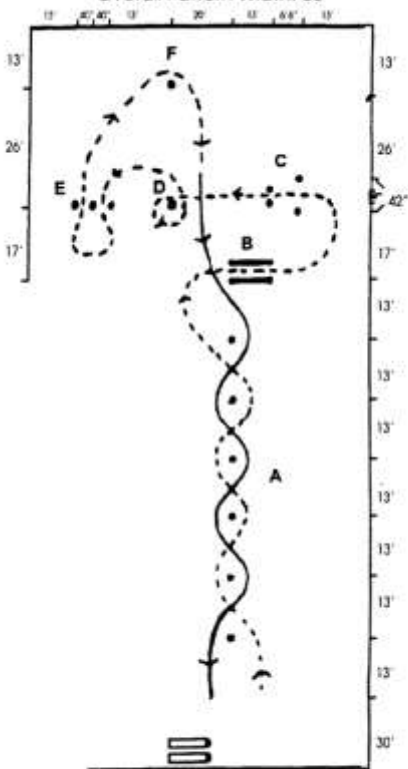

Overall Pattern Length: 177'  
Distance from any boundary: 13'

# WESTERN

## 165 General Western Rules

**A. Western Attire:** Exhibitors in all approved NASMA shows are required to wear long-sleeved shirt. Western hats, pants and boots in stock type halter, gymkhana events and western performance classes. Safety helmets are optional. The hat must be on the rider's head when the exhibitor enters the arena. Spurs and chaps are optional. Refer to Coon Jump rules for attire requirements in that class.

### **B. Western Bits:**

**1. Snaffles:** Whenever this book refers to snaffle bit in western performance classes, it means the conventional 0- ring, egg-butt, or D-ring with a ring no larger than 4". The mouthpiece should be round, smooth, unwrapped metal. It may be inlaid, but smooth or latex-wrapped. The bars must be a minimum of 5/16 in diameter, measured one inch in from cheek with a gradual decrease to center of snaffle. The mouthpiece may be two or three pieces. If it is three-piece, connecting ring of 1-1/2" or less in diameter, or a connecting flat bar of 3/8" or 3/4" (measured top to bottom, with a maximum length of 2"). which lie flat in the mule's mouth. Split reins or mecate reins are acceptable.

**2. Hackamores:** Whenever this book refers to Hackamore, it means the use only of a flexible, braided rawhide or leather, or rope bosal, the core of which may be either rawhide or flexible cable. Absolutely no rigid material will be permitted under the jaws, regardless of how padded or covered. This paragraph does not refer to the so-called mechanical hackamore.

**3. Bits:** Whenever this book refers to a bit in western performance classes, it means the use of a curb bit that has a solid or broken mouthpiece has shanks and acts with leverage. All curb bits must be free of mechanical device and should be considered a standard Western bit. A description of legal standard Western bit includes:

- a. Shanks:** 8-1/2" maximum length shank to be measured as indicated in the diagram. Shank may be fixed or loose.
- b. Mouthpieces:** With regard to mouthpieces, bars must be round, smooth and unwrapped metal of 5/16" to 3/4" in diameter, measured 1" from the cheek. They may be inlaid, but smooth or latex wrapped. Nothing may protrude below the mouthpiece (bar), such as extensions or prongs on solid mouthpieces. The mouthpiece may be two or three pieces. If it is a three-piece connecting ring of 1-1/4" or less in diameter, or a connecting flat bar of 3/8" or 3/4" (measured top to bottom with a maximum length of 2"). which lies flat in the mule's mouth, are acceptable.
- c. Port:** The port must be no higher than 3" maximum, with rollers and covers acceptable. Broken mouthpieces. half breed and spades are standard.
- d. Slip or gag bits, and donut and flat polo mouthpieces are not acceptable.**
- e. Curb Chains:** Chain chin straps are permissible only on curb, half-breed and spade bits, but must meet the approval of the judge, must be at least one-half inch in width, and must lie flat against the jaw of the mule.

**C. Romal:** Whenever this rule book refers to romal, it means an extension of braided material attached to closed reins. This extension on romal reins is to be allowed to be carried in the free hand with 16-inch spacing between the reining hand the free hand holding the romal.

- 1.** The romal shall not be used forward of the cinch or used to signal or cue the mule in any way. Any infraction of this rule shall be an automatic disqualification.

### Legal Western Bit

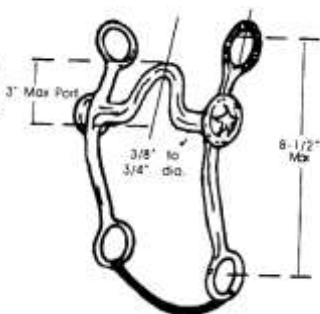

**D. Changing Hands on Reins:** Junior and Senior mules being shown in a shanked bit must be ridden with one hand on the reins, and the hand must not be changed. The hand is to be around the reins; index finger only between split reins is permitted. Violation of this rule is a severe penalty. No exhibitor violating this rule may be placed over another exhibitor, who did not violate this rule, regardless of their score.

**E. Saddles:** In all Western classes, mules and donkeys will be shown in a western saddle. Silver equipment will not count over a good working outfit.

### F. Optional Equipment:

1. Rope or riata: if used, the rope or riata must be coiled and attached to the saddle.
2. Hobbles attached to saddle.
3. Tapaderos, except in working cow mule when they are not allowed.
4. Protective boots may be used only in Gymkhana, Cattle, Jumping and Reining.
5. Spurs -not to be used forward of the cinch.

### G. Prohibited Equipment:

1. Wire chin straps, regardless of how padded or covered
2. Any chin strap narrower than one-half inch.
3. Martingales, nose bands, cavessons and tie-downs.
4. Any bit which has metal under the jaw, regardless of how wrapped. (exception: approved curb chains).
5. Any rein or reining type collar that is not attached to the bit.

### Acceptable Hand Position



### Unacceptable Hand Position

## 166 Western Terminology and Gaits:

The following terminology shall apply in all western classes whenever a specific gait is called for:

**A. WALK** is a natural, flat-footed, four beat gait. The animal must move straight and true at the walk. The walk should be alert, with a stride of reasonable length in keeping with the size of the animal. Excessive slowness that appears to be caused by intimidation may be penalized.

**B. JOG** is a smooth, ground-covering two-beat diagonal gait. The animal works from one pair of diagonals to the other pair. The jog should be square, balanced and with a straight forward movement of the feet. Animals walking with their back feet and trotting on the front are not considered performing the required gait. Pacing, prancing and jiggling may be penalized. When asked to extend the jog, the animal should move out with the same smooth way of going.

**C. LOPE** is an easy, rhythmical three-beat gait. Animals moving to the left should lope on the left lead and when moving to the right, they should lope on the right lead. Mules traveling at a four-beat gait are not considered to be performing a proper lope. The animal should lope with a natural stride appearing relaxed and smooth while showing proper cadence at a speed which is most comfortable for the individual. The head should be carried at an angle that is natural and suitable to the mule's conformation at all gaits.

## 167 Western Pleasure

The western pleasure class is an event judged on the rail designed to show an animals quality of movement, manners, and ability with both leads and transitions.

**A. Class Routine:** The animals are to be shown at a walk, jog and lope both directions of the arena. At the option of the judge, animals may be asked to extend the walk, jog or lope, one or both ways of the arena. The judge may ask all or just the top twelve (12) to extend the jog, but never more than 12 should be asked to extend the lope at one time. Riders should sit the extended jog. Animals are required to back easily and stand quietly either on the rail or in the line up. Animals are to be reversed to the inside of the arena at the walk or jog, but shall not be asked to reverse at the lope. The judge may ask for additional work of the same nature from any animal, but he/she shall not ask for work other than that listed above. Riders shall not be required to dismount except in the event the judge wishes to check equipment. This class will be judged on the performance of the mule and not conformation.

**B. Judging Considerations:** Animals should be shown on a reasonably loose rein, without undue restraint. Riders may be penalized if reins are draped so that control is not maintained. Quality of movement, attitude and consistency of gaits are of utmost importance in judging the Western Pleasure class. A good western pleasure animal has a free flowing stride of reasonable length in keeping with his conformation. Ideally, he should have a balanced, flowing motion while exhibiting correct gaits that are of proper cadence. The animals should be relaxed and responsive in all transitions. When asked to extend, he should move out with the same fluid forward motion, showing a lengthening of stride, without becoming quick or hurried. Passing is permissible and should not be penalized as long as the animal maintains a proper and even cadence. He should carry his head and neck in a comfortable position that is consistent with his conformation, parentage and degree of training. Maximum credit should be given to the cadenced, balanced and willing animal that shows quality movement, while appearing to be fit, well trained and a pleasure to ride.

### **C. Penalties to be scored according to severity:**

1. Excessive speed or failure to maintain control.
2. Loss of forward momentum, which results in excessive slowness or uneven cadence.
3. Breaking gait.
4. Being on the wrong lead.
5. Touching the animal with the free hand.
6. Consistent four beat canter.
7. Head and neck consistently carried too low.
8. Head and neck consistently carried too high.
9. Head consistently carried behind the vertical with the animal appearing intimidated.
10. Head carried consistently nosed out with the animal appearing resistant.
11. Gaits that are quick, choppy or pony strided.
12. Excessive stumbling.
12. Failure to take the appropriate gait when called for.
13. Animal appearing sullen, dull, lethargic, emaciated, drawn or overly tired.

### **D. Faults which may be cause for disqualification:**

1. Changing hands or two hands on reins, except when showing with a hackamore or snaffle bit.
2. Blatant disobediences including bucking, charging or rearing.
3. Use of spurs or romal forward of the cinch.
4. Obvious lack of control or danger to other exhibitors.

### **E. Walk/Trot (may be added to Mule or Donkey classes)**

1. *NASMA encourages open mule and/or donkey Walk/Trot competitions. Mules and donkeys may not be shown in the same class.*
2. *Mule is to be shown in western tack and attire. Legal bit requirements apply, although any age mule may be ridden in a legal snaffle bit or bosal with 2 hands.*
3. *Donkey is to be shown in western tack and attire. Donkeys may be ridden 1 or 2 handed with any legal bit. With equal performance, 1 hand will be placed over 2 handed.*

## **168 Western Riding**

Western Riding is a judged event, with the animal being ridden through a pattern of cones showing several changes of lead, quality of gaits, manners and maneuverability. Western riding is neither a stunt nor race, but it should be performed with reasonable speed.

**A. Judging Considerations:** Credit will be given for and emphasis placed on smoothness, even cadence of gaits (i.e. starting and finishing pattern with the same cadence), the mule's ability to change leads precisely and easily rear and front at the center point between markers. The mule should have a relaxed head carriage showing response to the rider's hands, with a moderate flexion at the poll. No mule shall be penalized for the manner in which he carries his tail nor for normal response with his tail to cues from his rider or when changing leads. The mule should cross the log both at the jog and the lope without breaking gait or radically changing stride. Maximum credit shall be given to the animal that exhibits correct, flying changes of lead.

**B. Class Routine:** The following patterns and routines are prescribed. It is essential that judge and exhibitors adhere to them.

1. On the pattern, the short, triple line represents a swinging gate at which the mule must put the rider in a position to open, pass through and close without dismounting. It may be located in any part of the arena and should be on which will not endanger mule or rider. Gate is optional in Pattern One and there is no gate in Pattern Two.
2. The eight small circles represent markers (cones and pylons only to be used.) These should be separated by a uniform measured distance of not less than thirty (30') feet nor more than

fifty (50) feet on the side with five markers (see diagram) It is recommended that markers be set a minimum of 15ft from the fence. The judge is responsible for correctness of the pattern.

**3.** The rectangle represents an obstacle (one small log recommended), minimum of eight feet in length. The long or serpentine line indicates the direction of travel and the gaits at which the mules are to move. The dotted line (.....) indicates walk, the dashed line ( \_ \_ \_ \_ ) indicates jog, and the solid line C.....) lope.

**C. Changing Hands on Reins:** Except for Junior Mules shown with a hackamore or snaffle bit, only one hand to be used and rider must not change hands except that it is permissible to change hands when opening gate if the gate is in such a position as to justify the change of hands.

**D. Scoring:** Scoring shall be on a basis of 0-100 with 70 denoting an average performance. Scoring guidelines to be considered: points will be added or subtracted from the maneuvers on the following basis, ranging from plus 1 point to minus 1 point; +1= excellent; +1/2= good; 0=average; -1/2= poor; and -1= very poor.

**E. Contestants will be penalized for:**

1. Releasing gate due to mules disobedience, unable to complete gate: 5 points
2. Use of free hand to instill fear in mule: 5 points
3. Breaking gait at lope, including simple lead change and engaging in a four beat lope: 3 to 5 points
4. Failure to complete a designated lead change: 5 points  
Failure to change lead from one half to one stride: 1/2 point  
Additional strides: 1 point per stride
5. Additional lead changes anywhere on course: 3 to 5 points
6. Hitting log: 1 point; Ticking (light touch) log: 1/2 point

**F. Disqualification:** A mule going off pattern is disqualified. Off pattern is any of the following

1. An incomplete pattern.
2. Incorrect order of maneuvers.
3. Knocking over markers.
4. Passing on wrong side of marker.
5. Missing the log.
6. Knocking over gate.

**G. Faults:** The following characteristics are considered as faults and should be judged accordingly.

1. Opening mouth excessively.
2. Anticipating signals or early lead changes.
3. Stumbling.
4. Any unnecessary aid given by the rider, such as unnecessary talk, petting, spurring or jerking of the reins.
5. Failure to start the lope within 20 feet of the log after crossing it at the jog.

## WESTERN RIDING PATTERN I

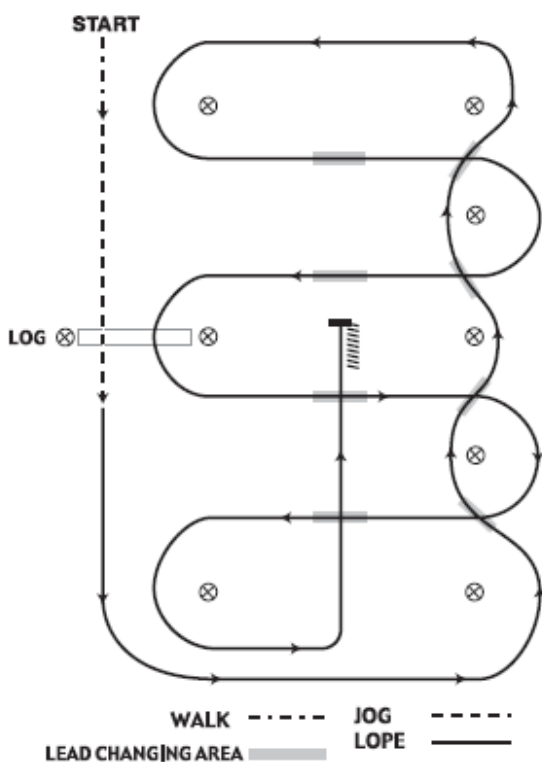

1. Walk at least 15' & jog over log
2. Transition to left lead & lope around end
3. First line change
4. Second line change
5. Third line change
6. Fourth line change lope around the end of arena
7. First crossing change
8. Second crossing change
9. Lope over log
10. Third crossing change
11. Fourth crossing change
12. Lope up the center, stop & back

## WESTERN RIDING PATTERN II

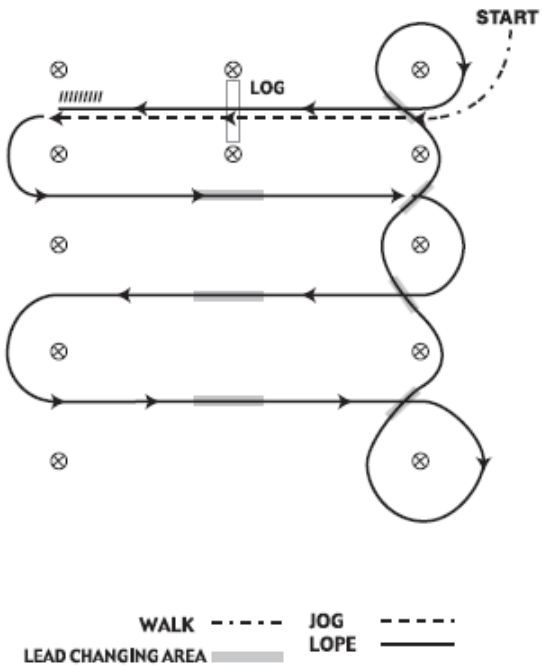

1. Walk, transition to jog, jog over log
2. Transition to the lope, on the left lead
3. First crossing change
4. Second crossing change
5. Third crossing change
6. Circle & first line change
7. Second line change
8. Third line change
9. Fourth line change & circle
10. Lope over log
11. Lope, stop & back

### WESTERN RIDING PATTERN III

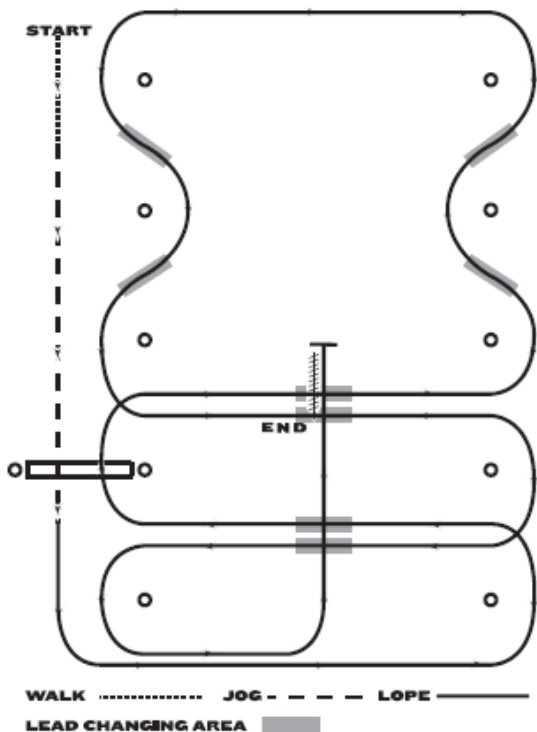

1. Walk halfway between markers, transition to jog, jog over log
2. Transition to the lope, on the left lead
3. First crossing change
4. Lope over log
5. Second crossing change
6. First line change
7. Second Line change
8. Third line change
9. Fourth line change
10. Third crossing change
11. Fourth crossing change
12. Lope up the center, stop & back

## Ranch Riding

Ranch riding is a judged event demonstrating the abilities of the animal while working over obstacles found in everyday ranch work.

**A. Judging Considerations:** Ranch riding is neither a stunt nor a race, but it should be performed at a reasonable speed. The mule should be judged on the quality of gaits, change of leads, and the ability to maneuver through and over the obstacles in a smooth and obedient manner.

1. Credit shall be given for and emphasis placed on a cooperative and obedient attitude in the mule as well as smoothness and even cadence of gaits. All gaits to be performed as described in western terminology.

2. Except for the Junior Mules shown with a hackamore or snaffle bit, one hand only allowed on the reins unless when opening the gate justifies the change of hands?

**B. Scoring:** Scoring guidelines are the same as Western Riding, Reining or Trail class when applicable.

**C. Penalties:** A contestant shall be penalized for:

1. Releasing the gate due to mule's disobedience, unable to complete gate: 5 points

2. Use of free hand to instill fear in mule: 5 points

3. Failure to complete designated lead change: 5 points

4. Refusal at obstacle: 10 points

5. Blatant disobedience: 5 points

6. Breaking of gait at lope: 3 points

7. Knocking down jump: 5 points Hitting or rolling log: 1 point

8. Ticking or light touch of log: 1/2 point

**D. Disqualification:** A contestant is disqualified for going off pattern. Off pattern is any of the following

1. . Incorrect order of maneuvers

2. Knocking over barrels

3. Passing on wrong side of markers or obstacles

4. Missing the log

5. Knocking over the gate

**E. Pattern Specifics:** The long or serpentine line indicates the direction of travel and the gaits at which the mule is to move. The dotted line (.....) indicates a walk and the solid line (\_\_\_\_\_) indicates lope. It is mandatory to walk over the bridge. No trotting or loping may be required over the bridge.

## RANCH RIDING PATTERN

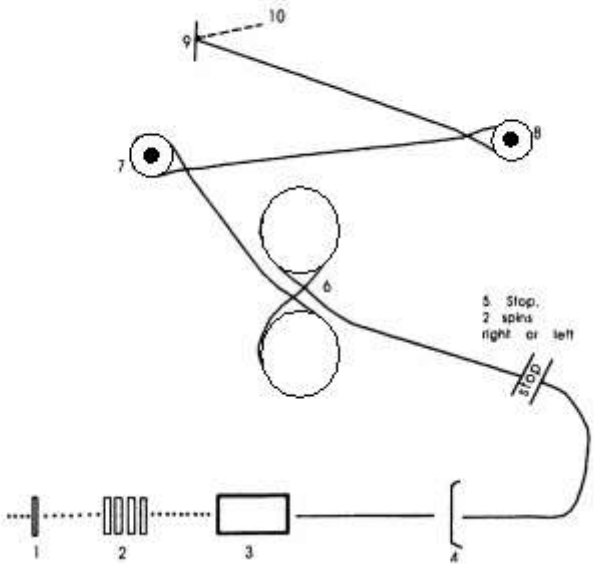

### F. Class procedure for Youth, Amateur, Junior and Senior

1. Work Gate
2. Walk Over Logs 20"-30" apart
3. Walk over bridge
4. Slow lope to and over 12" jump (distance between bridge and jump minimum 48' feet. Jump must be a minimum of 10' wide and no PVC is allowed.)
5. Stop and perform 2 spins, right or left
6. Proceed at medium lope to figure eight, showing change of lead from right to left circle.
7. Proceed with speed to barrel. Tight fast turn around barrel on left lead.
8. Proceed with speed to barrel showing change of lead from left to right. Tight fast turn around barrel on right lead.
9. Slide stop and back 10'.

### G. The following may be added to the Junior and Senior Pattern:

1. Dismount, hobble mule and walk a sufficient distance from animal to show ground tie. Reins should not be dropped. Unhobble and remount to exit.

## 170 Reining

Reining is a judged event designed to show an animals willingness to be guided through a pattern consisting of fast and slow circles, lead changes, sliding stops and spins.

**A. Class Routine and Pattern:** In an approved reining class, any one of the approved NASMA Reining Patterns may be used. One of the patterns is to be selected by the judge of the class and used by all contestants in the class. The judge shall indicate with markers on the arena fence or wall the length of the pattern.

Markers within the area of the pattern will not be used.

1. The pattern number must be printed in the premium notice, posted the day of the show or may be posted the first day of a multi-day show.
2. Each contestant will perform the required pattern individually and separately.
3. The judge will ask to see bits at the end of each performance.
4. Three markers or cones must be used for the convenience of the rider.

**B. Judging Considerations:** To rein a mule is not only to guide him, but also to control his every movement. The best reined mule should be willfully guided or controlled with little or no apparent resistance and dictated to completely. Any movement made on his own must be considered a lack of control. All deviations from the exact written pattern must be considered a lack of or temporary loss of control, and therefore faulted according to severity of deviation. Credit will be given for smoothness, finesse, attitude, quickness and authority in performing the various maneuvers while using controlled speed.

### **C. Scoring and Penalties:**

Scoring will be on the basis of 1-100 with 70 denoting an average performance

1. **Disqualification:** The following will result in a disqualification.
  - a. Failure to complete pattern as written
  - b. Performing the maneuvers other than in specified order;
  - c. The inclusion of maneuvers not specified;
  - d. Running away or failing to guide where it becomes impossible to discern whether the entry is on pattern;
  - e. Jogging in excess of 1/2 circle or 1/2 the length of the arena while staring a circle, circling or exiting a rollback.
  - f. Overspins of more than 1/4 turn
  - g. Use of illegal equipment
  - h. Willful abuse of an animal while in show arena or warmup arena
  - i. Using reins or romal as a whip
  - j. More than one finger between the reins
  - k. Two hands on reins except on Junior Mules ridden two handed with a hackamore (bosal) or snaffle bit.  
EXCEPTION: A rider may untangle excess rein, where excess rein may prevent the rider from continuing the pattern, where said excess can be straightened without affecting the performance of the mule, during hesitations, or when setting the mule; rider's free hand may be used to hold romal in the normal fashion.
  - l. Fall to the ground by mule or rider
  - m. Balking or refusal of command
2. **5 point penalties:** The following will result in a reduction of five (5) points:
  - a. Use of free hand to instill fear;
  - b. Holding saddle or touch mule with free hand.
3. **2 point penalties:** The following will result in a reduction of two (2) points
  - a. Failure to go beyond markers on stops and roll-backs.

- b. Break of gait
- c. Freeze up in spins or rollbacks

**4. Other penalty points:**

Starting circles or figure eights out of lead or delayed changes of lead will be judged as follows:

- a. Delayed change of lead by one stride: 1/2 point
  - b. From start to 1/4 circle: 1 point
  - c. From start to 1/2 circle: 2 points
  - d. From start to 3/4 circle: 3 points
  - e. For complete circle: deduct four points
5. Engaging in a jog or trot will be penalized as follows:
- a. Starting circle at a jog: 1/2 point
  - b. Exiting a rollback with a jog up to two strides: 1/2 point
  - c. Jogging beyond 2 strides, but less than 1/2 circle or 1/2 the length of the arena: 2 points
6. Overspins and Underspins will be judged as follows:
- a. Over or under spin up to 1/8 of a turn: 1/2 point
  - b. Over or under spin from 1/8 to 1/4 turn: 1 point
- A 1/2 point penalty deduction will be given for failure to remain a minimum of 20 feet from the wall or fence when approaching a stop and/or rollback.
7. Failure to change leads or late changes will be penalized as follows: Where a change of lead is specified immediately prior to a run to the end of the pen, failure to change leads will be penalized as follows:
- a. Failure to change leads by one stride: 1/2 point
  - b. Failure to change leads beyond one stride, but where lead change is completed prior to next maneuver: 1 point \
  - c. Lead is not changed prior to the next maneuver: 2 points
  - d. In patterns requiring a run-around, failure to be on the correct lead when rounding the end of the arena will be penalized: 1 point
  - e. (e.) Failure to be on the correct lead prior to the center point of the arena: 2 points

**D.** A judge may ask a contestant to repeat his performance of any or all of the various parts of the pattern

**E.** Faults against the mule (to be scored accordingly, but not a cause for disqualification):

- 1. Opening mouth excessively (when wearing a bit)
- 2. Excessive jawing, open mouth or head raising on stop
- 3. Lack of smooth, straight stop on haunches (bouncing, sideways stop)
- 4. Refusing to change leads
- 5. Anticipating signals
- 6. Backing sideways
- 7. Knocking over markers

**F.** Faults against the rider to be scored accordingly, but not a cause for disqualification.

- 1. Losing stirrup
- 2. Any unnecessary aid given by the rider (such as unnecessary talking, petting, spurring, quirting, jerking of the reins.)

**G.** Except for entries shown in a hackamore/snaffle bit, only one hand may be used on the reins and hand must not be changed. Hand is to be around reins, index finger only between reins is permitted. When a romal is used, it shall be carried as described in Western Equipment.

**H.** While mule is in motion, rider's hands shall be clear of mule and saddle.

**I.** Disqualification: Spurring forward of the cinch is an automatic disqualification.

## Reining Pattern 1

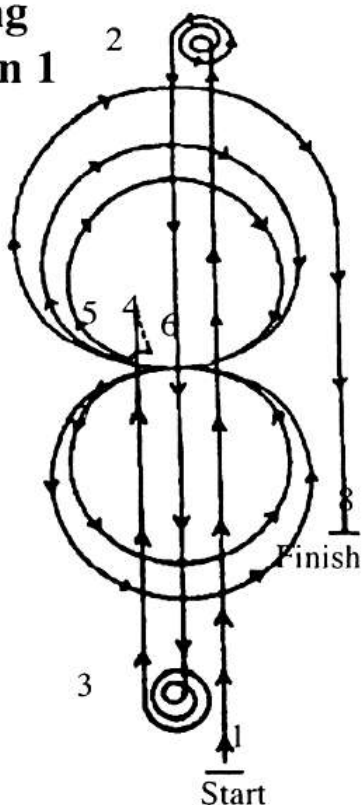

### MANDATORY MARKER ALONG FENCE OR WALL

1. Run to the far end of the arena, stop and do 2-1/2 spins to the left.
2. Run to the opposite end of the arena, stop and do 2-1/2 spins the right
3. Run past center marker, do sliding stop, no hesitation, back over slide tracks to center, hesitate.
4. Make a 1/4 pivot to the left to face left wall, hesitate.
5. Begin on right lead and make two circles to the right, the first small and slow, the second large and fast. Change leads at center of arena.
6. Make two circles to the left, the first small and slow, the second large and fast. Change leads at the center of arena.
7. Begin a large fast circle to the right. Do not close this circle, but run straight down the side past the center, do a sliding stop at least 20 ft from wall or fence.
8. Hesitate to show completion of pattern.
9. Walk to judge, stop for inspection until dismissed.
10. The bridle may be dropped at judge's discretion.

## Reining Pattern 2

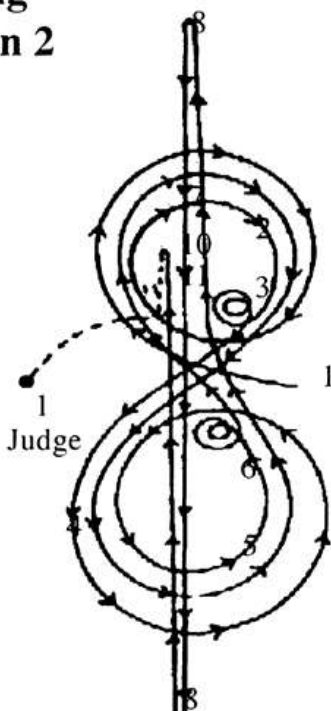

### MANDATORY MARKER ALONG FENCE OR WALL

1. Starting at the center marker make a large fast circle to the right.
2. Draw the circle down to a second smaller, slow circle until you reach the center of arena - stop.
3. Do two spins to the right. At end of spins mule should be facing the left wall, slight hesitation.
4. Begin on left lead and make a large fast circle.
5. Draw the circle down to a second smaller, slow circle until you reach the center of the arena - stop.
6. Do two spins to the left. Slight hesitation, mule to be facing left wall.
7. Begin on right lead and make a fast figure eight over the large circles, close the eight and change leads.
8. Run to far end of arena, stop (no hesitation) and do a left rollback.
9. Run to opposite end of the arena stop (no hesitation) and do a right rollback.
10. Run back past center marker and do a sliding stop. Hesitate.
11. Back over slide tracks.
12. Hesitate to show completion of pattern.
13. Walk to the judge for inspection and dismissal.
14. The bridle may be dropped at the judges discretion.

## Reining Pattern 3

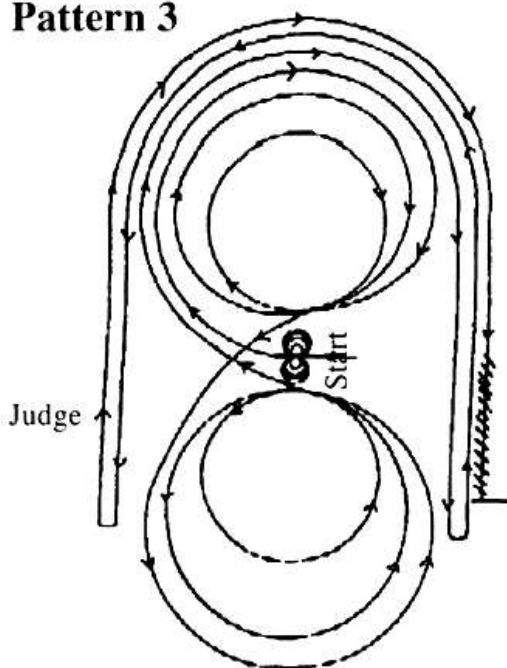

### MANDATORY MARKER ALONG FENCE OR WALL.

1. Begin at center, mule facing the left wall or fence.
  2. Complete four spins to the left
  3. Complete four spins to the right. Hesitate.
  4. Begin on right lead and complete three circles to the right. The first circle large and fast, the second circle small and slow, the third circle large and fast.
  5. Change leads at center of the arena.
  6. Complete three circles to the left. The first circle large and fast, the second circle small and slow, the third circle large and fast. Change leads at center marker.
  7. Begin a large fast circle to the right. Do not close this circle but run straight down the side past center marker and do a left rollback at least 20 feet from wall or fence, no hesitation\*.
  8. Continue back around top half of previous circle: do not close this circle, but run straight down opposite side of the arena past center marker and do a right roll back at least 20 feet from wall or fence - no hesitation\*.
  9. Continue back around previous circle, do not close this circle but run straight down the side past the center marker and do a
  10. Sliding stop at approximately 20 feet from wall or fence.
  11. Back straight to center of arena or at least 10 feet.
  12. Hesitate to demonstrate completion of pattern.
  13. Walk to judge, stop for inspection until dismissed.
  14. The bridle may be dropped at judge's discretion.
- \*Mule may come out of rollback on either lead, but should be on correct lead when rounding the end of the arena.

# Reining Pattern 4

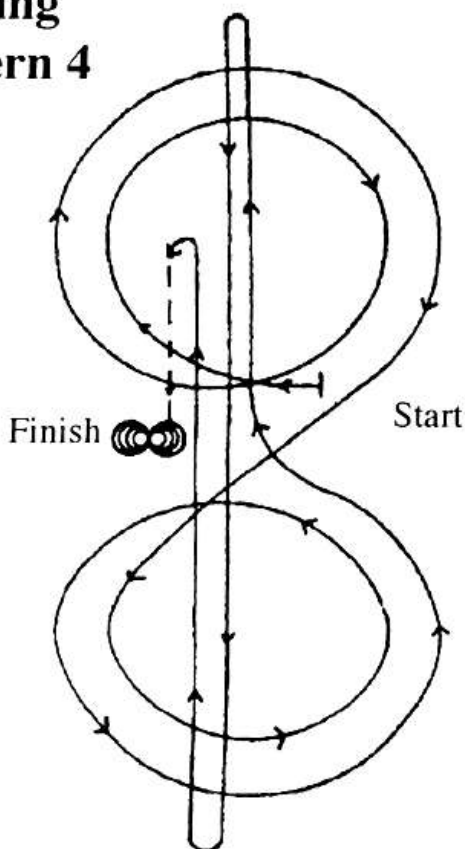

## MANDATORY MARKER ALONG FENCE OR WALL

1. Begin at center of the arena. Complete two circles to the right. The first circle small and slow, the second circle large and fast.
2. Change leads at the center of the arena.
3. Complete two circles to the left. The first circle small and slow the second circle large and fast.
4. Change leads at the center of the arena.
5. Run to the far end of the arena, past end marker and do a left rollback, no hesitation.
6. Run to the opposite end of the arena, past end marker and do a right rollback, no hesitation.
7. Run past center of arena and do a sliding stop.
8. Back straight to center of the arena. Hesitate.
9. Complete four spins to the right.
10. Complete four spins to the left.
11. Walk to the judge, stop for inspection until dismissed.
12. The bridle may be dropped at the judge's discretion.

## 171 . Reined Working Donkey

**A.** In contrast to Donkeymanship, this class is intended to evaluate the donkey and its willingness to be controlled.

**B. Pattern:** Either of these two patterns may be used. It is suggested that the more difficult Pattern I be used at larger shows and the easier Pattern 2 be used at smaller shows.

**C. Class Routine:** Each contestant will perform the required pattern individually and separately. To rein a donkey is not only to guide him, but also to control his every movement. The best reined donkeys should be willingly guided or controlled with little or no apparent resistance and dictated to completely. Any movement on his own must be considered a lack of control. All deviations from the exact written pattern must be considered a lack of or temporary loss of control, and therefore faulted according to severity of deviation. Credit will be given for smoothness, finesse, attitude, quickness and authority in performing the various maneuvers while using controlled speed.

**D. Equipment:** Donkeys may be shown with any approved bit, either snaffle, hackamore or curb, using one or two hands. Once a contestant has committed to either showing one handed or two handed, the style of holding the reins may not be changed during the class. Given equal performance, a donkey ridden with one hand should be placed above one ridden with two hands.

## Reined Working Donkey Pattern 1

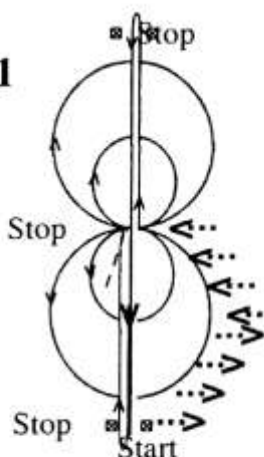

1. Start trotting at designated cone and demonstrate lateral movement (leg yield) at the trot to the right; at next cone, without stopping, demonstrate lateral movement (leg yield) at the trot to the left. Stop at center of arena. Hesitate. Do a quarter turn left to face left center arena wall.
2. Take a right lead and make 2 circles to the right, the first small and slow and the second large and fast.
3. Show a change of lead at the center of the arena.
4. Make 2 circles to the left, the first small and slow, and the second large and fast.
5. Show a change of lead at the center of the arena.
6. Hand gallop between and past cones at far end of arena. Stop.
7. Turn on haunches to left and hand gallop between and past cones at near end of arena. Stop.
8. Turn on haunches to the right and hand gallop to center of arena. Stop.
9. Back (straight) at least 10 feet.
10. Walk to judge and stop for inspection if requested, exit arena at a trot.

## Reined Working Donkey Pattern 2

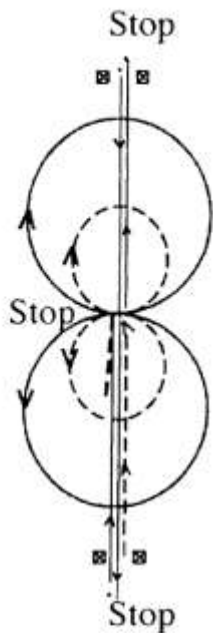

1. Starting at designated cone, trot to center of arena and then trot a small Figure 8 pattern.
2. At center of arena, lope on the right lead to the right in a large circle.
3. At center of arena, show a change of lead and lope in a large circle to the left.
4. At center of arena, show a change and lope between and past cones at far end of arena. Stop.
5. Turn on haunches to left and lope between and past cones at near end of arena. Stop.
6. Turn on haunches to the right and lope to center of arena. Stop.
7. Back (straight) at least 10 feet.
8. Walk to judge and stop for inspection (if requested), exit at a trot.

## 172 Trail

**A. Gaits:** See Western Terminology for gaits to be performed between the obstacles.

**B. Posting of Pattern:** Pattern must be posted at least one hour before the class or may be posted the first day of a multiple day show.

**C. Pattern Specifics:**

1. A minimum of six obstacles will be used, three of which are mandatory and at least three others selected from the approved list. Care must taken to avoid setting up any of these obstacles in a manner that may be hazardous to the mule and rider.

Obstacles not combined shall be a minimum of 9' (nine feet) apart. Management, when setting courses, should keep in mind that the idea is not to trap a mule, eliminate it or make it look silly by making an obstacle too difficult or scary looking.

2. The course must be designed to require each mule to demonstrate walk, trot and lope somewhere between the obstacles as part of the working course. Enough space must be provided for the judge to evaluate the gait. Enough space should be provided for a mule to jog (at least 30 feet) and lope (at least 50 feet) for judges to evaluate these gaits. The mule's way of going should be appropriate for a trail mule. Points may be added or subtracted from a mule's total score on the obstacles based on his attitude, manners, style and way of going, but the mule with major faults on the course (knock-downs, etc.) should not place ahead of a mule that worked the obstacles cleanly.

3. If course is disrupted, the course cannot be reset and re-measured until the contestant finishes the entire course, regardless of where the disruption takes place.

4. If difficult courses are set, Youth, Junior and Novice trail should be less difficult.

5. Mules must not be required to work on the rail.

**D. Changing Hands on Reins:** Exhibitor may use only one hand on the reins except for junior mules or Green mules that are ridden in a snaffle bit or hackamore with two hands. Hands may not be changed except when:

1. Putting on or removing the slicker.

2. Carrying an object from one part of the arena to another.

3. Dismounting

4. Working the gate.

**E.** While the mule is in motion, riders hand shall be clear of mule and saddle.

**F. Safety of Course:** The judge has the right and duty to alter the course in any manner or remove any obstacle, including mandatory obstacles, he/she deems unsafe. If at anytime a trail obstacle is deemed unsafe by the judge, it shall be repaired within a reasonable amount of time or removed from the course. If it cannot be repaired within a reasonable amount of time and mules have completed the course, the score for that obstacle will be deducted from all previous works for that class.

**G.** All courses and obstacles are to be constructed with safety in mind so as to eliminate any accidents. Consideration should be given to Youth and Novice riders and their safety and Junior Mules for their level of training.

**H. Judging Considerations:** Trail is a class mules should excel in as compared to horses. Courses should be challenging, but, at no time, attempt to ridicule or make the mule look silly to the spectators. Courses should be designed to exhibit the finesse, sure-footedness and calm capability of the mule as a superior trail animal.

1. This class will be judged on the performance of the mule over obstacles. Judges will assign a point value to each obstacle and points will be added to or subtracted from this

score based on the mule's performance over that obstacle.

**2.** Credit will be given to those mules negotiating the obstacles cleanly, smoothly, and smartly with style and prompt response to the rider's cues. Any mule performing with an artificial or mechanical appearance should be penalized. Mules should also be penalized for touches and knockdowns of any elements of the course and for unnecessary delay in approaching the obstacles.

Extreme variation of gaits is to be penalized as in not engaging a true Western gait as defined in Western Terminology.

**3.** Exaggerated standing in stirrups and leaning forward over mule's neck by the rider should be penalized. Riders shall be penalized for obviously cuing their mule on the neck or anywhere forward of the cinch.

**4.** A true trail mule should be relied upon to investigate an obstacle to determine its safety. A mule cannot be penalized for investigating an obstacle, if the obstacle is then negotiated calmly and safely.

#### **I. Disqualifications:**

**1.** Failure to follow course will result in disqualification.

**2.** Major disobedience such as rearing at an obstacle will result in disqualification from the class.

**3.** Willful abuse by the exhibitor toward the mule will result in disqualification from the class.

**4.** Illegal equipment or lack of equipment will result in disqualification from the class.

**J.** Failure to complete an obstacle shall not be a disqualification, but is to be severely penalized.

#### **K. Mandatory Obstacles:**

**1. GATE** - The gate must be set up so that it is a minimum of four feet in length and four feet in height and so that the contestant can open from his right side or left side. The rider may not change hands or lose control of the gate while passing through.

**2. BRIDGE** - A bridge with a wooden floor at least 6 feet in length not to exceed twelve inches in height and with or without side rails not less than thirty-six inches apart will be used. Mules must not be asked to trot over or lope over bridge.

**3. BACK THROUGH** - Backing obstacles to be spaced a minimum of 28"; if elevated 30" is required.

**a.** Back through and around at least three markers.

**b.** Back through L, V, U, straight or similar shaped course. May be elevated no more than 24".

#### **L. Optional Obstacles:**

**1. Water hazard** (ditch or small pond). No metal or slick bottomed boxes will be used.

**2. Simulated water hazard** made of a plastic tarp, secured to the ground, so that it will not become affixed to the mule's foot when a mule passes over the simulated water.

**3. Serpentine obstacles** at a walk or a jog. Spacing to be a minimum of 6' for a jog.

**4. Carry an object**, other than a live animal and of a reasonable size and weight from part of the arena to another. (Only objects which reasonable might be carried on a trail ride may be used.)

**5. Ride over at least four logs or poles.** They can be in a straight line, curved, zigzag or raised. The space between the logs is to be measured and the path the mule is to take should be the measuring point. The space for walkovers shall be 20-24"; trot overs 3'-3'6", lope overs 6-7'. Walkovers may be elevated 12" and should be minimum of 22" apart. The height should be measured from the ground to the top of the element. Trot overs may be elevated 12" and should be a minimum of 3' apart. Lopeovers cannot be elevated. Trot overs cannot be

elevated in novice, 13 & under or 10 & under classes. All elevated elements must be placed in a cup, notched block, or otherwise secured so they can not roll.

**6. Put on and remove a slicker.** When this obstacle is used, it will be so located that the rider can ride to the slicker, put it on and remove it and return it to a designated place. Reins may be held or dropped on the neck of the mule or over the saddle horn while so doing.

**7. Side pass** (may be elevated to a 12" maximum.) An object of such a nature and length which is safe and lying on the ground may be used to demonstrate the responsiveness of the mule to leg signals. The obstacle may be designed to require the mule to side pass either or both ways or in a pattern.

**8. Box:** An obstacle consisting of four logs or rails, each 5' to 7' long, laid in a square. Each contestant will enter the square by riding over log or rail as designated. When all four feet are inside the square, rider should execute a turn, as indicated and depart.

**9. Mail Box** - Remove and/or replace items. Side pass is optional.

**10. Lime Circle** - Requiring a turn on the forehand with front feet inside and back feet turning on outside of lime circle. May also be performed with hind feet in circle showing a pivot.

**11. Drag or Pull** - An object other than an animal or fowl which can be reasonable pulled or dragged without the contestant having to daily may be used. Dallying is not allowed.

**12. Any other safe and negotiable** obstacle which could reasonably be expected to be encountered on a trail ride and meets the approval of the judge may be used.

#### **M. Prohibited Trail Obstacles:**

1. Tires
2. Live animals
3. PVC pipe
4. Jumps
5. Rocking or moving bridges
6. Water box with floating or moving parts
7. Flames, dry ice, fire extinguisher
8. Logs or poles elevated in a manner that permits such to roll.
9. Ground Tie
10. Dismounting

BACK THROUGH & AROUND THREE MARKERS.

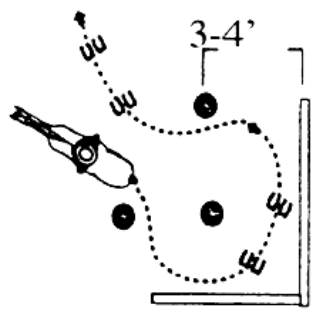
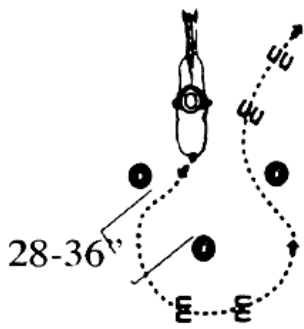
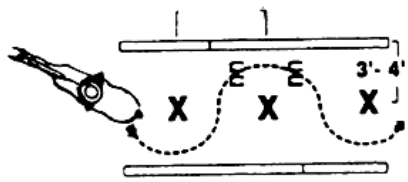
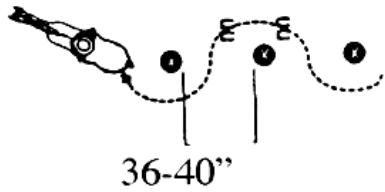

les

## Variations of the Sidepass

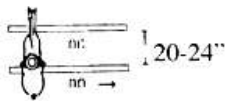

*raised object*  
(no more than  
12 inches)

5-6'

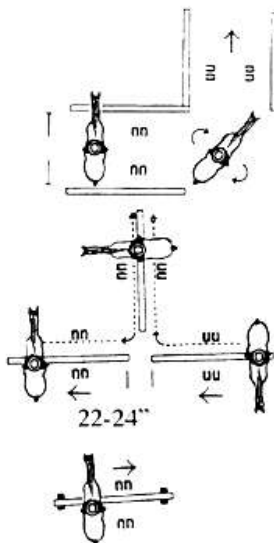

## Trot Overs, Lope Overs & Walk Overs

These can be used to combine all three in one obstacle.

*Can use Walk Overs, Trot Overs and Lope Overs in One Class*

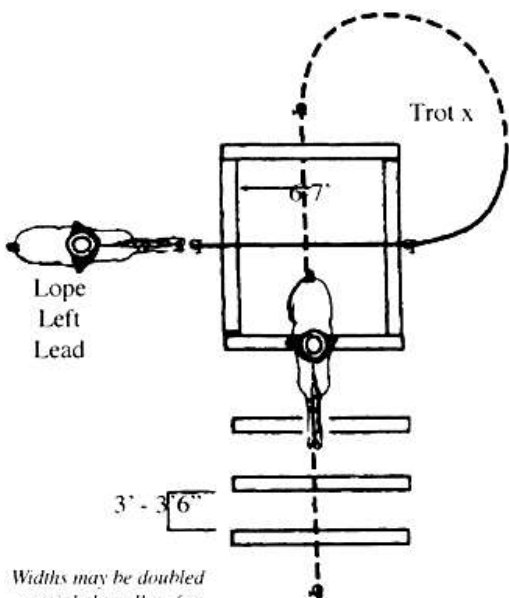

*Widths may be doubled  
or tripled to allow for  
more than one stride  
between poles.*

# CATTLE CLASSES

## 173 Working Cow Mule

**A.** Both the cattle working part of this event and the reining part are mandatory. Emphasis on scoring the cow work portion shall be based on the mule maintaining control of the cow at all times, exhibiting superior cow sense and natural cow working ability without excessive reining or spurring. Failure of an exhibitor to at least attempt to complete the cow work portion of the class, as well as the reined work, will result in the exhibitor not being considered an entry in the class. A mule which attempts to complete the cow work but does not finish for any reason other than the two-minute time limit; deliberate spurring or use of the romal forward of the cinch; or is out of control while working, thus endangering the rider will be scored accordingly at the judges discretion. A mule going off pattern in the reined work will receive a score of zero (0). A mule which attempts both the reined work and the cow work portions may be placed, even if disqualified in one portion of the class. (For Example: If a mule is disqualified and receives a 0 score for the reined work, but scores a 70 for the cow work, its total score would be 70 and the mule would be eligible for placing.

### **B. Prescribed Rein Work:** (pattern)

1. The approved pattern will be used and each contestant will cause his mule to travel at the gait indicated for each part of the pattern. When judging reined work, the judge should refer to the reining portion of the handbook for guidelines.
2. In approved working cow mule classes, any of the three approved NASMA working cow mule patterns may be used. One of the three is to be selected by the judge of the class, posted on the premium list or on the day of the class and used by all contestants in the class.
3. The judge may request additional work at his/her option.

### **C. Prescribed Cow Work**

1. At start of cow work, each contestant, upon receiving a cow in the arena, shall hold the cow on the prescribed end of the arena for sufficient time to demonstrate the ability of the mule to contain the cow on that end. After a reasonable amount of time, the contestant shall take cow down the fence, making at least one turn each way on the fence. Then the contestant shall take that animal to an open part of the arena and take the animal in a circle at least once in each direction.
2. This is an ideal cow work; however, the judge should take into consideration the size of the arena, condition of ground and the disposition and degree of difficulty exhibited by the cattle worked.
3. Cattle work may be done immediately following each individual's pattern work or immediately after completion of pattern work by all mules being exhibited (at the judge's discretion).
4. The cattle working portion of the working cow mule class must be completed within two minutes.
5. If time and number of cattle permit, the judge may, at his her discretion, award new cattle based on the following criteria:
  - a. The cow can't or won't run;
  - b. The cow won't leave the end of the arena;
  - c. The cow is blind or won't yield to the mule;
  - d. The cow leaves the arena.

### **D. Scoring And Penalties:**

Scoring will be on the basis of 0 - 100, with 70 denoting an average performance. The same basis of scoring shall apply to both the reined work and cow work. In the event of a tie, the entry with the highest cow work will be declared the winner. \

**E. Penalties:**

- 1. 5 point penalties:** Not getting one turn each way on the fence work
- 2. 3 point penalties:**
  - a. Biting or striking the cow
  - b. Hanging up on the fence.
  - c. Exhausting or overworking the cow.
  - d. Failure to hold cow on end of the arena.
  - e. Knocking down the cow without having a working advantage.
- 3. 2 point penalties:**
  - a. Failure to show sufficient control of cow while circling.
  - b. Going past the corner of the arena before turning the cow when going down the fence.
- 4. 1 point penalties:** Loss of working advantage.
  - a. Mules that run past the cow shall be penalized 1 point for every mule's length past the cow.
- 5.** Each time the arena is crossed to use the opposite fence to achieve a turn.
- 6. 0 (zero) score:**
  - a. Mule turns tail to the cow.
  - b. Fingers between the reins.
  - c. Deliberate spurring or use of the romal forward of the cinch.
  - d. Leaving the work area before the pattern or work is complete.
  - e. During the cow work, use of two hands on the reins, except with jr. or green mules ridden with two hands in a snaffle or bosal.
  - f. Any mule that is out of control while working the cow, thus endangering the rider (i.e. Crossing the path of the cow) shall be called off the cow.
  - g. Any mule that runs over the cow thus causing the fall of mule and/or rider shall terminate the work at that time.

**F.** Fall of mule and/or rider while being shown either in cow work or reined work shall not eliminate the entry.

**G. Faults:** The following characteristics are considered faults;

1. Exaggerated opening of mouth;
2. Hard or heavy mouth;
3. Nervous throwing of head;
4. Lugging on bridle;
5. Halting or hesitation while being shown, particularly when being run out, indicating anticipation of being set up.
6. Losing a cow or being unable to finish a pattern because of a bad cow, the contestant shall be penalized at the judge's discretion. Touching the mule or saddle with the free hand except during the cow working portion of the class, the rider may hold onto the horn.

**H. The Characteristics of a good working cow mule are:**

1. Good manners
2. Mule should be shifty, smooth and have its feet under it at all times; when stopping, hind feet should be well under it;
3. Head should be maintained in its natural position;
4. Mule should be able to work at reasonable speed and still be under control of the rider.
5. A soft mouth and should respond to a light rein, especially when turning.

**I.** A show may have up to two cow working classes.

1. Senior cow working mule shown with a legal bit, with one hand on the reins.
2. Junior cow working mule shown in a snaffle, hackamore or legal shanked bit.

3. If one working cow class is offered, it should be "Open working cow mule. When a romal is used, it shall be carried as described earlier in this rule book.

## Working Cow Mule Pattern 1

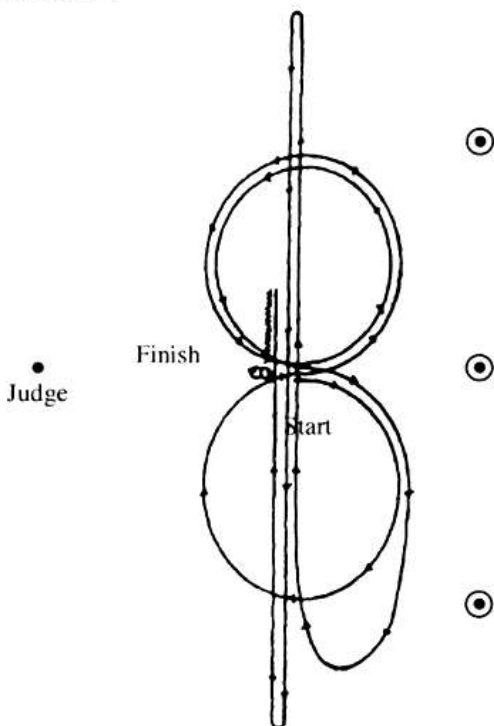

### MANDATORY MARKER ALONG FENCE OR WALL.

Ride pattern as follows:

1. Beginning at the center, facing right wall or fence, take a right lead and do a circle to the right, away from the judge, of moderate size and speed.
2. At the center of the arena, change leads and do two circles to the left both of moderate size and speed.
3. At the center of the arena, change leads.
4. Go to the end of the arena without stopping or breaking gait, and begin run down near the approximate center of the arena; run the length of the arena past marker.
5. Do a square, sliding stop, hesitate.
6. Turn left and begin a run to the opposite end of the arena; run length of arena past the marker.
7. Do a square, sliding stop, then hesitate.
8. Turn right, and begin a run down past the center marker of the arena.
9. Do a sliding stop, and back to the center of the arena or at least 10 feet. Let mule settle in approximate area of stop.
10. Do a 360° spin to the right.
11. Do a 360° spin to the left.
12. Hesitate to show completion of pattern.
13. Approach judge for inspection and dismissal.

## Working Cow Mule Pattern 2

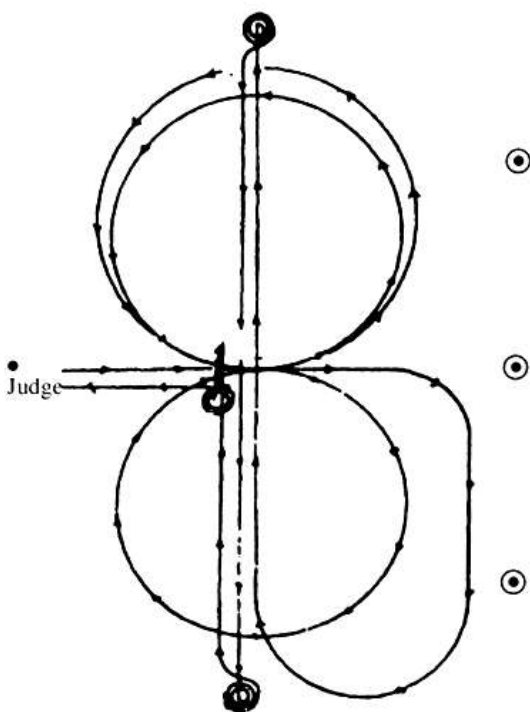

### MANDATORY MARKER ALONG FENCE OR WALL.

Ride pattern as follows:

1. Begin at the center of arena, facing right wall or fence. Take a right lead and complete a circle to the right, away from the judge.
2. At the center of arena, change leads and do two circles to the left, of the same size and speed.
3. At the center of arena, change leads.
4. Go to the end of the arena and without stopping or breaking gait, start the run near the approximate center marker of the arena. Run full length of arena.
5. Do a square sliding stop, hesitate.
6. Do 2-1/2 spins right.
7. Run full length of arena past marker and do a square sliding stop, hesitate.
8. Do 2-1/2 spins left.
9. Run past center marker of arena; do a square sliding stop.
10. Back to center of arena (minimum 10-15').
11. Do a 360° spin right or left.
12. Do a 360° spin opposite direction taken in #11.
13. Hesitate to show completion of pattern for inspection and dismissal.

## Working Cow Mule Pattern 3

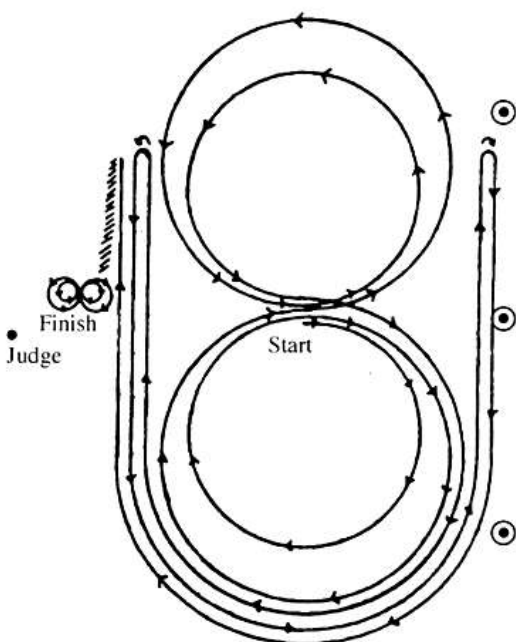

### MANDATORY MARKER ALONG FENCE OR WALL.

Ride pattern as follows:

1. Begin at the center of arena, facing right wall or fence. Take a right lead and do two circles to the right, away from the judge: the first small and slow; the second large and fast.
  2. At the center of arena, change leads and do two circles to the left: the first large and fast; the second small and slow.
  3. At the center of arena, change leads and begin a circle to the right. Do not close this circle, but run straight down the side past the center marker and do a left rollback at least 20 feet from the wall or fence, no hesitation.\*
  4. Continue back around the previous circle. Do not close this circle, but run straight down opposite side, past the center marker, and do a right rollback at least 20 feet from the wall or fence, no hesitation.\*
  5. Continue back around previous circle. Do not close this circle but run straight down side past center marker and do a sliding stop at least 20 feet from wall or fence.
  6. Back to the center of arena or at least 10 feet and then hesitate.
  7. Do two spins to the right.
  8. Do two spins to the left.
  9. Hesitate to demonstrate completion of the pattern.
  10. Approach judge for inspection and dismissal.
- \* Mule may come out of the rollback on either lead; however, it should be on correct lead when going around the end of the arena.

## 174 Team Penning

**A.** NASMA recommends using the USTPA rulebook as a guideline for Team Penning. This can be obtained from USTPA, P0 Box 161848, Ft. Worth, TX 76161-1848, 817-847-1264.

**B. Class routine:** Within a 90-second time limit, a team of three riders must cut out from the herd and pen three head of cattle with the assigned (same) identity number of neckband or same number on side. The fastest time wins.

### Course Design for Team Penning

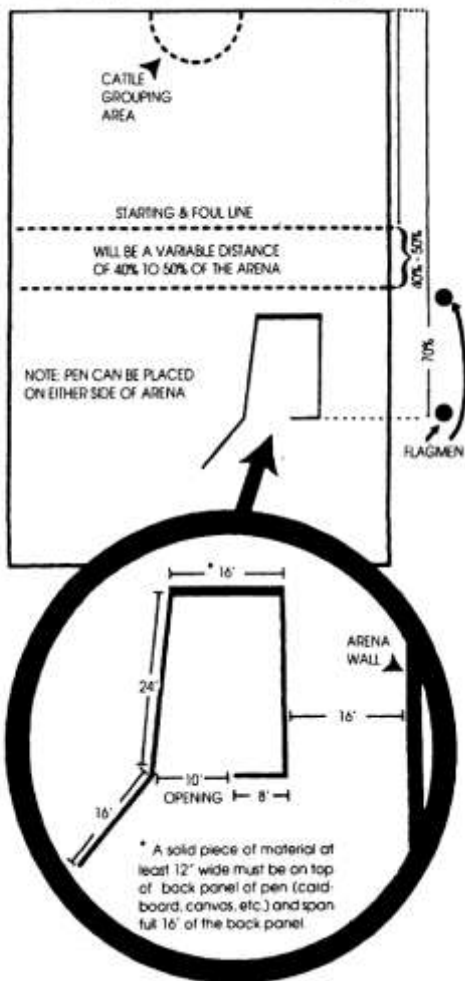

**C. Flagmen, Timekeepers:** There will be two flagmen, one at the entrance to the pen and one at the start/foul line. The judge must be located at the start/foul line, and may or may not actually flag the contest at his/her discretion. There shall be at least two timekeepers. The first timekeeper shall be the official time and the second timer shall be the backup time, in the event the first timer misses the time or his/her watch fails. The starting and foul line must be designated by markers located on the arena fence, and easily viewed by the line judge and the exhibitors.

**D. Cattle:** The optimum number of cattle per herd is thirty (30). However, a maximum of 45 head are allowed and a minimum of 2 1 head per herd is required even if there is less than seven (7)

teams. All cattle within a herd must be numbered in groups of three.

1. There must be three (3) head of assigned (identical numbers or neckbands) cattle per team in the herd as each new team begins a run.
2. There must always be the same number of cattle in each of the herds used in a go-round.
3. In the event that more or less than three assigned (identical numbers) cattle are discovered within a herd, the team(s) with more or less than three assigned cattle must have a rerun at the end of the total go-round. Times for all other teams within such a mis-numbered herd will remain the same.
4. Cattle cannot be reused with a go-round for a division except as specified above.

**E. Cattle Numbers:** Numbers must be a minimum of 6 inches tall and neckbands must be a minimum of 6 inches wide. Numbers must be applied to both sides of the animal, high up on its side, with the top near the midline of the animals back between the shoulder and the hip. The numbers and working order will be drawn for by the judge and show management before the start of the contest.

**F. Start of Run:** All cattle will be bunched on the cattle side of the starting line before the time begins. The line flagman will raise the flag to signal when arena is ready. Contestants will be given their cattle penning number when the line flagman drops his flag as the nose of the first mule crosses the starting line. Riders are committed once they enter the arena. Any delay will be disqualification.

**G.** Once committed to the cattle, the team is completely responsible for their animals. It is the team's responsibility before working the cattle to pull up and call for a judge's decision if, in their opinion, there is an injured or unusable animal in their numbered cattle. Once the cattle are worked, no excuses are accepted. If an animal leaves the arena, either over or through the fence, the team can either be disqualified for unnecessary roughness, or can be given a rerun, depending on the judge's decision. If a rerun is given, it must be given at the end of the last go-round. If no fresh cattle are available for reruns, the cattle to be used will be determined by the show management and judge. If more than one rerun is given in any go-round, they will be taken in order of occurrence. If cattle are to be reused and additional fresh cattle are needed, the used cattle must be mixed with the fresh cattle and renumbered. Every attempt must be made to insure each team work the same number of used and fresh cattle.

**H. 30 Second Warning:** A warning must be given to the team working the cattle at 30 seconds prior to a final time being called. In the event a warning is not given, a rerun may be given at the request of the team. If the team requests a rerun, the cattle will be settled and a rerun will be given immediately using the same numbered banded cattle, with a 60-second penalty.

**I. Calling for Time:** A team may call for time with only one or two assigned cattle penned. However, teams penning three head of cattle place higher than two, and two higher than one, regardless of time. In a multiple go-round contest, in the event that teams pen their cattle in only one go-round contests, teams that pen in each go round will beat teams that fail to pen in a go-round, regardless of the number of cattle penned or time. For example: times in three go-round beat times in two go-rounds. Times in two go-rounds beat times in one go-round. Time in one go-round beats no time. In multiple go-rounds, times are accumulated to determine placings.

1. To call for time, one rider must stand in the gate of the pen and raise a hand for the flag. Flag will drop when the nose of the first mule enters the gate and the rider calls for time. All undesignated cattle must be completely on cattle side of

starting line. If a team calls for time with only one or two of their cattle in the pen, the remainder of their designated cattle DO NOT have to be on the cattle side of the starting line.

2. A team calling for time with any wrong number neckband cattle in the pen will be judged no time.

**J. Disqualification:**

1. Contact with cattle by hands, hats, ropes, bats, romal or any other equipment is a disqualification.

2. A team will be disqualified by the judge for any action he/she feels to be unnecessary roughness to the cattle or mules, or unsportsmanlike conduct.

**K. No Time:**

1. A team exhibiting any unnecessary roughness will be judged no time.

2. If five or more head are across the starting line at any one time, that team will be judged no time.

3. A team calling for time with any wrong number cattle in the pen.

**L. No hazing with whips, hats or ropes allowed. Romals or reins may be swung or popped on chaps.**

**M. Fall of mule and/or rider shall not eliminate the entry; however, any attempt by a dismounted rider to work cattle before remounting will result in an automatic disqualification.**

**N. Reruns:** In the event a team is given a number that has already been used within a given herd, a rerun must be given immediately, using the correct number within the same herd. Should the error be discovered after the herd has been removed from the arena, then the rerun will be given at the end of the total go-round using the same herd.

**O. No Show:** If for any reason a team does not show after the order of go has been drawn, their cattle number will be drawn in the order the team would have run. The drawn number will not be used in that set of teams. This will avoid changing the order to go for the other contestants.

**P. Ties:** In the event of a tie affecting the placing, each team will be allowed to pen one numbered animal. Fastest time breaks the tie.

**Q. Entries:** A mule may be entered only once per division, but exhibitors may enter up to three mules in each division.

**R. Points:** Points will be awarded based on the number of teams entered. For every five teams there will be a point awarded to each of the three winning team members. Example: 9 teams: 1<sup>st</sup> place team - each team member will receive 3 points; 2nd place team - each team member will receive 2 point; 3rd place team - each team member will receive 1 point.

## 175 General Roping Rules

**A. Judged or timed:** At the discretion Show Management roping classes may be judged or timed f timed, the local show committee rules will apply and a NASMA approved judge is not required to be in attendance. It must be stated on the premium list whether the roping classes will be timed or judged. If timed, the applicable rules must be made available to the contestants.

**B. Judging:** If roping classes are judged events, only the performance of the mule is judged. Time is not to be a factor.

**C. Scoring:** For judged roping events, scoring will be based on a 0- 100 basis with 70 denoting an average performance.

**D. Barrier:** Breaking the barrier is a fault and not a disqualification in judged events.

**E. Specifying entry:** A mule shall be allowed to show in heading or heeling, or both, but must specify which one before the run. When two or more go-rounds are held, each team of mules and ropers must be the same and work in identical and consecutive order.

**F. Box, barrier:** Mules in calf roping and the heading mule only (whether being judged or not) in dally team roping must start from behind a barrier (an electronic barrier is acceptable.) All mules in roping events must start from the roping box.

**G. Roping prior to flag:** In all roping events the contestant shall not attempt to rope the animal until the barrier flag has been dropped. Any attempt by a contestant to position the mule behind the barrier enabling the contestant to rope the animal without attempting to leave the box shall be considered disqualified.

**H. Reruns:** At the judges discretion, a rerun may be given if the animal being roped leaves the arena or in the event of a malfunction of the chute or barrier.

**I. Equipment:** In roping events Western style equipment must be used. Use of a tiedown, mechanical hackamore or other type of bridle is the optional choice of the contestant; however, the judge may prohibit the use of bits or equipment he/she may consider severe.

**J. Conduct:** Any unsportsmanlike conduct or animal abuse will be cause for disqualification.

**K. Ties:** Ties will be broken with a runoff or flip of the coin if both contestants agree.

**L. Judging faults:** Breaking the barrier, or any unnecessary whipping, jerking the reins, talking or any noise making, slapping, jerking rope or any unnecessary action to induce the mule to perform better, will be considered a fault and scored accordingly.

**M. Timers:** Two timers will be used. An electronic timer will be used when available as first timing device and a stop watch will be used as back up. When there is a significant difference between the two times (3 seconds or more), a re-ride can be given at the judge's discretion.

**N. Points:** If a contestant competes on multiple teams with the same mule in team penning, only one (1) placing in that particular class with that mule may count toward NASMA points or any show high point. If a contestant competes on multiple teams with the same mule in team roping, the mule may earn points for only two (2) placings. one placing earned while heading and one placing earned while heeling.

## 176 Calf Roping

**A.** Roper will start from behind a required barrier.

**B.** Barrier will be a minimum of 5 feet and a maximum of 15' feet.

**C.** Any catch that holds is legal, but rope must remain on calf until tie is complete and roper has remounted. Calf must stay tied until roper remounts and rides forward to put slack in the rope.

**D.** A mule can compete only once in the calf roping class.

**E. Loops-** A maximum of two minutes or two loops, which ever comes first, will be allowed. If both loops are missed, contestant must retire from arena.

**E.** If more than one loop is thrown, roper must carry second tied to saddle which must be used for second loop.

**F.** A chute judge is required and the flagman must be mounted for the entire class.

**G.** Jerk down -If a calf is jerked down, it must be allowed to regain its feet and roper must throw the calf by hand, tie any three feet with not less than one complete wrap and half hitch. If calf is jerked down so it is upside down with all four feet in the air, this will be cause for disqualification.

## 177 Team Roping (Judged)

**A.** Each contestant will select the other member of his/her team.

**B.** Ropers will start from behind required barrier.

**C.** The roper may throw only two loops and this must be done within a two-minute time limit. If more than one loop is thrown, the roper must recoil rope and build additional loop or loops. If the roper fails to catch, he/she will retire from the arena with no score.

- D.** The header must head the steer and heeler must heel the steer. Mules cannot switch positions.
- E.** Legal catches in heading are both horns, half head and around the neck. Any figure-eight catch or front leg in the catch is illegal.
- F.** Heeling- The heeling mule will be judged in box with ease it sets and stops the steer and holds rope in the proper position for header facing the steer. The rider may throw only two loops. If roper misses both, header and heeler must retire from the arena.
- G.** Legal catches in heeling are defined as a catch which holds from behind steer's shoulders and back, around flank, or on one or both heels, but not by tail only.
- H.** The rider must daily on the mule being judged. The mule not being judged may tie, daily or pull tight.
- I.** It is an automatic disqualification when both the header and heeler fail to complete both catches within two minutes from the time the steer leaves the chute. It is an automatic disqualification for either the header or heeler to loose their rope.
- J.** Riders are to stay mounted. When both ropes are dallied and both mules are facing stretched, run is complete. The rope must be wrapped around the saddle horn at least on complete turn before it is considered a daily.

## **178 Steer Stopping (Judged)**

- A.** Mule is to be judged on manners behind the barrier and all other times. The mule shall be judged on the rate of speed to steer, ability of mule to rate, check, stop straight and to stop and turn the steer to face mule.
- B.** There is a time limit of two minutes or two loops, whichever comes first. If roper fails to catch, he will retire from the arena with no score.

## **179 Cutting**

- A.** The North American Saddle Mule Association strongly recommends that NASMA-approved cutting classes be held whenever the interest and entries justify. The pertinent rules are available from NCHA, 4707 Highway 377 South, Fort Worth, TX 76116.
- B.** The most current National Cutting Horse Association rules shall be used as pertain to holding a class and judging it.
- C.** All riders in the arena shall comply with NASMA rules on dress, equipment and conduct and be limited to bona fide contestants or their helpers.

## **180 Steer Daubing**

- A.** Exhibitor will be furnished a mop with shortened strings that has been dipped in white wash.
- B.** Exhibitor will start from behind a barrier. The object is to daub anywhere from point of shoulder to point of the hip within the rib cage area and not on the spine of the cattle.
- C.** Exhibitor must raise the stick in the air to signal completion of the run.
- D.** There will be a one (1) minute time limit. A ten (10) second penalty will be assessed for breaking the barrier.

## **181 Team Sorting**

*Team sorting is rapidly growing in popularity in equine associations across the Nation. To keep up with the needs of our members, I propose to approve Ranch Sorting as a recognized NASMA class in addition to the association's current list of cattle classes:*

- A.** *Western Attire and Tack.*
- B.** *OBJECTIVE: Team Sorting is a timed event consisting of two riders with the objective of sorting ten head of cattle from one pen into another in a designated sequence. The team that sorts all ten head in the correct order with the fastest time will be*

*declared the winner. A Ranch Sorting run begins with ten numbered cattle, 0-9, and two unnumbered cattle for a total of 12 head behind a foul line in an arena with two people mounted on the other side of the foul line.*

*C. SORTING PENS: Ranch Sorting will take place between two pens of approximately equal size with show management's option of working cattle back and forth or only one way. Two ranch sorting arenas may be placed side by side with teams alternating odd and even numbers.*

*D. SETTLING EACH HERD. If cattle are to be worked back and forth, they need to be moved to the opposite pen and back before each new herd entering the arena is worked.*

*E. . READABLE NUMBERS: All cattle must have approved back numbers; neck numbers are not acceptable.*

*F. RECOMMENDED PEN SIZES: Recommended sorting area to be 50-60' in diameter with no 90 degree corners, i.e. 60' round pen or octagonal "stop sign" design.*

*G. GATE OPENING SIZE: The start/foul line will be recommended as a 16' opening, but no smaller than 12' opening between the two pens.*

*H. JUDGE: There will be a minimum of one judge for sorting, to be positioned evenly with the foul line.*

*I. TIME: There will be either a 90, 75, or 60 second time limit for each class, at the option of show management. Time will continue until all cattle are sorted or the time limit is reached. A lap timer is to be used in sorting classes to eliminate ties only. As clarification, the lap timer will be utilized ONLY in the case of a situation where a tie (or ties) occurs, e.g., in a situation where a team sorts 8 head and has a time of 75 seconds with a lap time of 64.32, while another team sorts 10 head in 68.32 seconds, clearly the 10 head team will be in the lead. The lap timer will then be used only to break ties of all the 8 head runs in that go. Also, for breaking ties with multiple go rounds, the lap time will be the determining factor and eliminate the ties by setting the order of combined times for placing purposes.*

*J. BUNCHING CATTLE: All cattle will be bunched on the cattle side of the gate within the designated area before the time begins. Judges will designate the need to bunch cattle.*

*K. STARTING THE RUN: The judge will raise the flag to signal when the arena is ready. The flag will drop when the nose of the first mule or donkey crosses the start/foul line and the announcer will provide the number to be sorted first. The riders will be given their number instantly. Any delay in crossing the foul line may result in a "no-time" for the team.*

*L. ORDER OF SORTING: The cows are sorted in order; if any part of a numbered cow crosses the start/foul line prior to its correct order, then the team receives a no time. If any part of a sorted cow re-crosses the start/foul line the team will be disqualified. If any part of any unnumbered cow crosses the foul line before the tenth cow is cleanly sorted, it will result in a no-time.*

*M. RANDOM START NUMBER: The order of sorting is determined by the picking of a random number by the Announcer/Timer and then that cow must be sorted first; for instance if 5 is drawn as the first number, then the 6 cow must be sorted, 7, 8, 9, 0, 1 and so on.*

*N. COW CONSIDERED SORTED: A cow is considered sorted when the entire cow is completely across the start/foul line.*

*O. COWLEAVING THE ARENA: If a good cow jumps any fence and either leaves the arena, or ends up in the opposite pen, but did not pass through the gate, it will result in a re-ride for that team at the end of the herd, (assuming it was not caused by roughing), and time cannot be improved.*

**P. DIVISIONS.** *There will be three divisions only. Mules and donkeys may be entered only once per division. All mules and donkeys exhibited must meet the ownership and registration requirements for the division in which they are entered.*

**1. Open, All Ages.** *In keeping with the rules of all other classes, exhibitors may enter four mules and two donkeys, two Junior and two Senior mules and two donkeys of any age, regardless of sex.*

**2. Amateur.** *Exhibitors may enter two mules and two donkeys. All exhibitors in this division must possess current NASMA Amateur cards.*

**3. Youth.** *Exhibitors may enter two mules and two donkeys.*

**Q. POINTS.** *Points will be awarded based on the number of teams entered. Each mule or donkey on the team will be awarded points based on the NASMA point System.*

**R. MINIMUM/MAXIMUM NUMBER OF GO-ROUNDS:** *In a multiple go round contest, the minimum number of goes shall be two with a first go and a finals. The maximum number of goes shall be 100% to the first go, either 30% or 50% back to the second go, and a finals. Show management must advertise the number of go-rounds in advance.*

**S. MUST SORT CLEAN TO ADVANCE:** *Teams must sort cleanly to advance to the next go-round.*

**T. SIZE AND ORDER OF FINAL GO-ROUND:** *If 99 teams or less entered, the finals shall have a maximum of up to 10 teams; if 100 teams or more, up to 20 teams will advance to the finals. For all finals, the running order will be determined by draw, either by mechanical draw or by hand draw.*

**U. CALCULATING PLACING BY CLEAN SORTS:** *Teams sorting in three go-rounds place higher than teams that fail to sort in a go-round, regardless of the number of cattle sorted or time. Teams sorting in two go rounds place higher than teams that fail to sort in a go-round, regardless of the number of cattle sorted or time accrued.*

**V. AMPLE HERDS:** *Show management must have enough cattle that no herd is re-sorted during the first go.*

**W. RE-RIDE SITUATIONS:** *Should a herd be misnumbered or have too many non-numbered cattle, the team may receive a re-ride.*

## GYMKHANA EVENTS

### 181 General Rules for Timed Events

**A. Attire:** See Western Attire

**B. Equipment:** See Western Tack (NOTE: In Gymkhana events, Hackamore Gag bits i.e. Martha Josey or Lynn McKenzie type and tiedowns are a legal bit.

**C. Hat:** The rider's hat or helmet must be on his/her head when he or she enters the arena. The rider should be reminded that loosing a hat and taking the time to retrieve it is time consuming and may add significant and expensive time to a show. It is recommended the rider secure the hat or helmet in such a way that if it should be knocked off that it will not fall to the ground. .

**D. Timer:** An electronic timer will be used when available as first timing device and a stop watch will be used as back up. When there is a significant amount of difference between the two times (3 seconds), a re-ride should be given.

**E. Starting line:** In all speed events, mules and donkeys should be given a running start. A clearly marked starting line is required. It is recommended that there be at least 45 foot running start before the starting line. If the arena does not afford at least a 45 foot running start, it is recommended that the contestant be allowed to begin the run outside the arena from a point that is 45 feet from the

starting line. Caution should be exercised to keep spectators and other exhibitors out of the way of a contestant who is beginning a running start outside the arena.

**F. Conduct:** Any unsportsmanlike conduct or animal abuse will be cause for disqualification.

**G. Gates:** All gates will remain closed until run is over.

**H. Ties:** Ties will be broken with a runoff or the flip of a coin if both contestants agree.

**I. Time limit:** In any of the timed classes, an animal will have no more than 1 minute to cross the starting line or engage the first obstacle before being disqualified.

**J. Abuse:** The judge will disqualify a contestant for any excessive use of a bat, crop, spurs, whip, rope or hand in front of the cinch.

## 182 Pole Bending

**A.** Pole bending is a timed event. Each contestant will begin from a running start, and time shall begin and end as the mule's nose crosses the line. (A clearly visible starting line shall be provided.) Electronic timer or at least two stop watches shall be used, with the time indicated by the electric timer or the average time of the watches used by official timers to be the official time.

**B.** When measuring the area for the poles, it is recommended that there is ample room for the mules to complete their turns and stop at the finish and to have a 45' foot running start as outlined in General Rules.

**C.** The pole bending pattern is to be run around six poles. Each pole is to be 21' feet apart, and the first pole is to be 21' feet from the starting line. Poles shall be set on top of the ground, six (6') feet in height, with no base more than fourteen (14") inches in diameter.

**D.** A mule may start either to the right or to the left of the first pole and then run the remainder of the pattern accordingly. (see pattern).

**E.** Knocking over a pole shall carry a five (5) second penalty. Failure to follow the course shall cause disqualification. A contestant may touch a pole with his or her hand in pole bending without penalty. Breaking the time line on the return pass shall be a disqualification.

### POLE BENDING PATTERN

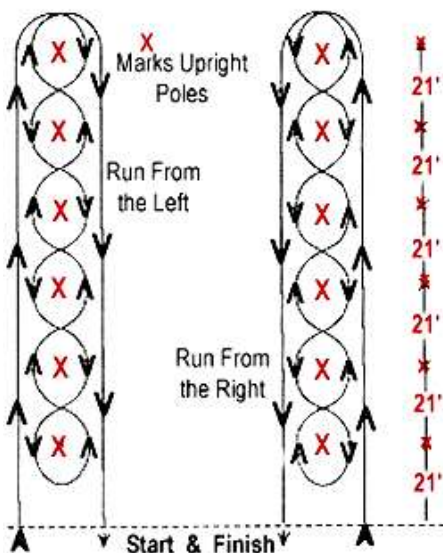

## 183 Barrel Racing

**A.** Barrel racing is a timed event. The course must be measured exactly.

**B.** When measuring the area for the barrel course, it is imperative to leave ample room for mules and donkeys to complete their turns and stop at the finish. It is recommended that there be at least 45' foot running start before the starting line as outlined in General Rules, at least 18' feet from barrels 1 and 2 to the fence, and 36' feet from barrel 3 to the end of the arena.

**1.** If the course is too large for the available space, the pattern should be reduced (5) yards at a time until the pattern fits the arena. It is recommended that adequate space be left between barrels and any obstacle. The distance from the barrel number 3 to the finish line need not be reduced 5 yards at a time if there is sufficient room for the mule to stop. Brightly colored 55 gallon steel drums with both ends intact are recommended. Rubber pads, plastic barrels, or rubber barrels may be used.

**C.** All starting line marker or electric timers shall be placed when at all possible against the arena fence. An electric timer or at least two stop watches shall be used, with the time indicated by the electric timer or average time of the watches used by official timers to be the official time.

**D.** The contestant is allowed a running start. Timing shall begin as soon as the mule's nose reaches the starting line and will be stopped when the mule's nose passes over the finish line.

**E.** At a signal from the starter, the contestant will run to barrel number 1, pass to the left of it and complete an approximately 360 degree turn around it; then to barrel number 2, pass to the right of it, and complete a slightly more than 360 degree turn around it; then to barrel number 3, pass to the right of it, and sprint to the finish line, passing between barrel number 1 and 2.

**F.** This barrel course may also be run to the left.

**G.** Knocking over a barrel shall carry a five (5) second penalty.

**H.** Failure to follow the course shall cause disqualification. A contestant may touch the barrel with his/her hands in barrel racing.

**I.** In the event of a tie, there will be a run off or flip of the coin if both contestants agree.

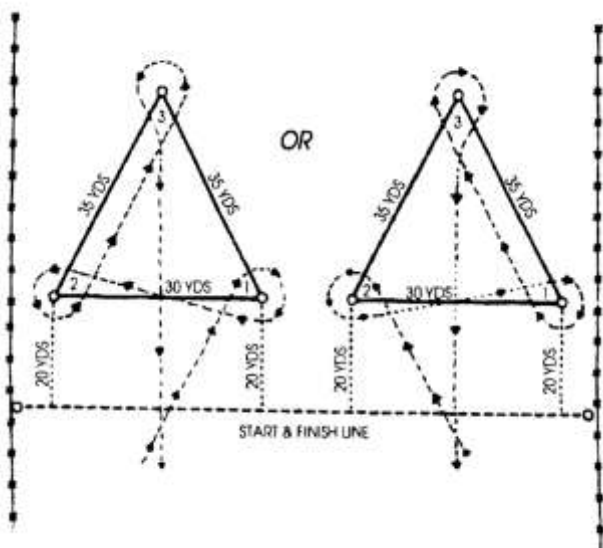

## 183 Keyhole Race

A. Keyhole is drawn on the ground with white lime in the following dimensions:

1. Lane - 4' foot wide and 8 feet long
2. Circle - 20' feet in diameter
3. Center of circle to be 150' feet from timing line.
4. The back of the circle should be at least 30' feet from the end of the arena.

B. Contestant is allowed a 45' foot running start as described in General Gymkhana rules.

C. Contestant enters lane, turns animal around in the keyhole circle, and races back down the lane to the finish line.

D. Stepping on or out of any of the lines results in disqualification.

E. Timer starts as mule's nose crosses the starting line and stops as mule's nose crosses it on the return.

F. It is the show management's responsibility to see that the keyhole line is clearly visible at all times.

### Keyhole Pattern

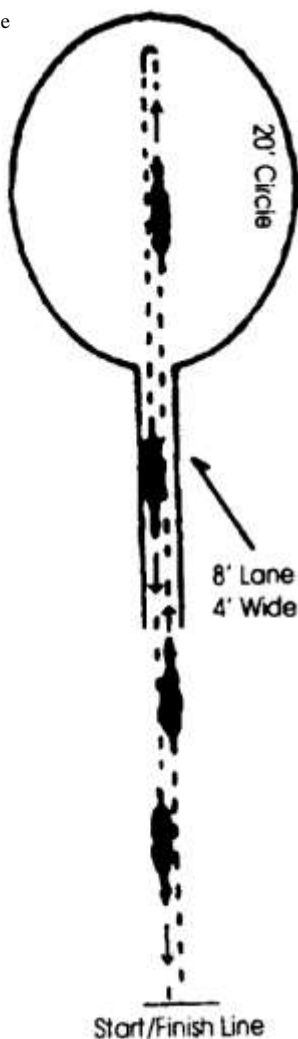

## 184 Pylon Alley

- A.** An alley with the following dimensions is set up with pylons (traffic cones) 21' feet from timer line, 5' feet wide, 21' feet between side cones and end set of cones, 5' feet between the 3 cones set at the end with the center cone placed in the center of the alley.
- B.** Contestant is allowed a 45' foot running start as described in General Gymkhana rules.
- C.** Knocking over any cone or stepping across the center cone results in disqualification.
- D.** Timer starts as the mule's nose crosses the timer line and stops as the mule's nose crosses on the return.
- E.** In the event of a tie, there will be a run off or flip of a coin if both contestants agree.

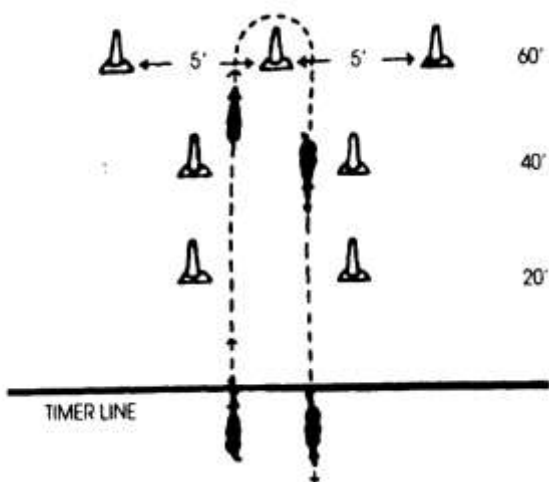

## 185 Cones and Barrels

- A. A timed event, in which the course is to be measured exactly.
- B. The course will be set as follows:
1. Three cones placed down the center of the arena at 21 feet intervals from the timer line.
  2. Then the barrel pattern to be set as listed in class 183 Barrel Racing.
  3. The contestant would start on either side of the cones weaving the cones then running a barrel pattern and then weaving the cones the opposite way back out when coming home from the third barrel. **EXAMPLE:** if the contestant would wish to be turning the right barrel first they would start the pattern by weaving the left side of the first cone then right side of the second cone then the left side of the third cone going on the right barrel and running a barrel pattern when leaving the third barrel the contestant would weave the cones left right left and crossing the timer line to finish the pattern.
- C. Knocking over any of the obstacles would result in a five second penalty.
- D. Missing any part of the pattern, loss of forward motion or weaving the cones in the wrong order would result in a disqualified run.

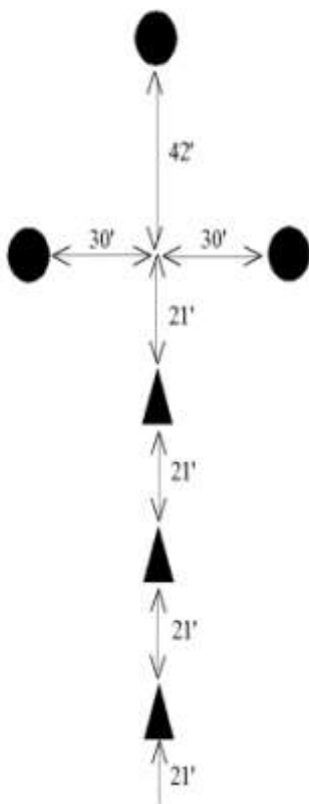

## 186 Flag Race

- A.** The Flag Race is a timed event. Contestants will be allowed a 45' foot running start before the starting line as described in the General Gymkhana Rules.
- B.** A barrel is set at the far end of the arena at least 18 feet from the end of the arena.
- C.** A can or bucket filled with sand or dirt of approximately five gallon size will be set on top of the barrel. A flag secured to a stick approximately 15" inches long is set in the can or bucket.
- D.** Contestant must circle barrel, pick up the flag and carry it across the finish line.
- E.** *Striking the animal with the flag, failure to circle the barrel or carry the flag across the finish line will result in disqualification.* Timer starts as mule's nose crosses the starting line and stops as mule's nose crosses the finish line.
- F.** In the event of a tie, there will be a runoff or flip of the coin if both contestants agree.

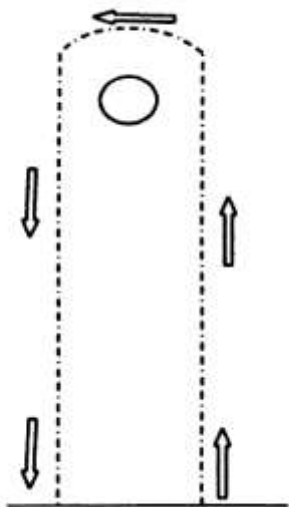

# GAITED

## 188 General Gaited Rules

**A.** In regard to rules governing Gaited Mules in NASMA shows, every effort has been made to include all rules governing these mules in this Gaited Section. However, should there be any questions not addressed in this section regarding the exhibition of Gaited Mules in a NASMA approved event, NASMA rules in this official rule book will apply.

**B. ATTIRE & TACK** See Saddle Seat OR Western Attire depending on the class

**1.** In all Gaited Mule Western classes, western attire and tack is to be used. Mules will be shown in a western saddle.

**a.** Optional equipment: spurs, chaps, gloves, rope or riata

**b.** Prohibited equipment: Australian saddles, cavasson, crops, mechanical hackamores, martingales, training paraphernalia, action devices, tie downs, tack collars, jerk lines.

**2.** In all Gaited Mule English type classes, Saddle Seat attire and cutback saddles are mandatory.

**3.** In Saddle Seat classes a saddle seat habit of a two or three button saddle suit of a solid conservative color is correct both day and evening.

**4.** In all Gaited Mule Western type classes, exhibitors in all approved NASMA shows are required to wear long-sleeved shirt. Western hats. pants and boots in stock type halter, gymkhana events and western performance classes. Safety helmets are optional.

**5.** In all Gaited Mule Driving type classes, Drivers should be dressed conservatively according to the style of present day, either Western or English is acceptable. Ladies wearing a skirt should wear a lap apron. A hat of choice, long sleeves and gloves are required.

**6.** In all Gaited Halter Mule type classes, either English or Western attire adhering to the above rules is acceptable.

**C. TACK** All mules must use English tack, except where division or class rules permit otherwise. All mules must use a Standard Walking Mule Single Rein Bridle and Bit, except where division or class rules permit otherwise. Neither quick change bridles and reins nor gag bits with no shanks are allowed. Curb chains are permitted.



**1. BITS:** Gaited bits are recognized as any standard Walking Horse bit. Severe bits are discouraged and bleeding from the mouth or muzzle is reason for disqualification. These bits are curbs with a solid or broken mouthpiece. A description of a legal Gaited Mule bit for Mules 5 yrs and older and Mules 4 yrs and younger includes:

**a.** 9½ maximum length shank to be measured as indicated in the diagram. Shanks are measured from the very top of the metal to the very bottom of the metal, including the rings to which the cheeks and reins are attacked. Shank may be fixed or loose.

**b.** With regard to mouth pieces, nothing may protrude below the mouthpiece. Solid or broken mouthpieces may have a port no higher than 3 inches. Smooth round, rubber, wrapped copper wire, twisted wire, double twisted wire, Tom Bass

port are acceptable. Bits featuring mouth pieces with cathedral, donuts prong edges or rough, sharp material shall be cause for elimination.

c. Gag bits are acceptable.

**2. BRIDLES:** Mules will be shown in standard Walking Mule Bridles with closed English type reins in English classes and split or romal reins in Western classes. Curb chains must meet the approval of the judge and be at least on-half inch in width and must lie flat against the jaw of the mule.

### **3. ENGLISH TACK**

a. **SADDLE:** English cutback saddles of the flat or deep seat forward seat, Australian and stock seat saddles are prohibited.

b. **BRIDLE:** All mules must use a Standard Walking Mule Single Rein Bridle and Bit

c. **WHIPS:** Whips can be used in under saddle classes (English only) and halter classes but must not exceed 4 feet in length including the snapper.

### **4. WESTERN TACK.**

a. **SADDLE:** Western tack requires a western style saddle.

b. **BRIDLE:** Western tack requires a western style bridle with no cavasson. Any standard Walking Horse bit is acceptable with a shank length of the bit not exceeding nine and one half (9 ½) inches. Curbs are allowed, chain or leather, but must be at least one half (½) inch wide and must lay flat against the mule's jaw. Split or romal reins are also allowed.

c. **WHIPS:** Whips are not allowed in western classes.

### **5. DRIVING TACK:** Also see Driving Rules.

a. **FINE HARNESS:** A correctly fitting harness is essential for the comfort of the harness mules and donkeys. A wider saddle is suggested for two wheeled vehicles as more weight rests on the mules and donkey's back. Narrower saddles are more appropriate for four wheeled vehicles.

b. **BRIDLE:** should fit snugly to prevent catching on the vehicle or other pieces of harness. A throatlatch and a noseband or cavasson is mandatory.

(1) Martingales and overchecks are prohibited in obstacle classes.

(2) Failure to comply incurs elimination.

(3) Bits

(a) Snaffle bits and other types of traditional driving bits are allowed. Bits may be covered with rubber or leather.

(b) Legal bits include:

ii) Half cheek snaffle

iii) Liverpool

iv) Elbow Driving

v) Bradoon Overchecks

c. **WHIP:** An appropriate whip shall be carried at all times while driving. The thong on the whip must be long enough to reach the shoulder of the farthest mules and donkeys. A driver not in compliance will be disqualified...

**D. SHOEING** Toe length must exceed the height of the heel by one (1) inch or more. The length of the toe shall be measured from the coronet band, at the center of the front pasterns along the front

**1. BAREFOOT** - Barefoot mules may be shown in flat shod classes, however, judge must disqualify lame or tender footed mules.

**2. Flat Shod Mules** - Applying to all four feet, the mule is shod flat hoof to toe. The shoe shall be made in a manner either conventional or hand made. The shoe must not exceed 2 inch in thickness or 12 inches in width. No pads allowed. No additional weight shall be allowed on or in the hoof, other than the shoe and nails. Lubricants in the pastern area, action devices, pads and

artificial appliances are prohibited on the Flat-Shod Pleasure Mules.

**3. HEAVY SHOD - Plantation Shod -** Applying to all four feet, the mule is shod with a shoe not to exceed 2 inch in thickness and 12 inch in width; with no bare plate or other weight inside the shoe. The caulk must not exceed a one inch turnback and the shoe must not extend more than 3 inch beyond the hoof at the toe. The heel of the shoe must not extend beyond the bulb of the mule's heel to the ground. The use of barium is permitted on the caulks of the pleasure shoes, but the thickness of the shoe and caulk with the barium must not exceed 1inch. Welded on clips are not permitted on flat-shod mules. Clips that are drawn from the shoe itself are permitted.

**4. LIGHT SHOD -** Applying to all four feet the mule is shod with a shoe no wider than : inch and no thicker than d inch with the exception of the caulk, which must be no thicker than : inch, and the turnback shall not exceed one inch. The shoe is not to extend beyond the bulb of the mule's heel when a perpendicular line is drawn from the bulb of the mule's heel to the ground. The use of barium is permitted on the caulks of the pleasure shoes, but the thickness of the shoe and caulk with barium must not exceed f inches. The use of hoof bands on lite-shod mules is not permitted in the show ring or on the show grounds. Welded on clips are not permitted on flat shod mules. Clips that are drawn from the shoe itself are permitted.

**5. SHOW MULES ARE NOT BE SHOWN AT NASMA APPROVED EVENTS.** A Show Mule (Shown with pads) is a mule that has received training to enhance the natural gaits associated with its breed type. Such mules perform with boots or action devices which give an added dimension to their performances in the ring

#### **E. GENERAL GAITED RULES -**

**1.** All mules must exhibit a saddle gait other than a trot - such as a smooth, easy gait such as a single-foot; a running walk, a rack, a stepping pace; Paso Fino; Foxtrot; etc.

**2. ABUSIVE TREATMENT** Abusive treatment and/or training techniques to produce alteration of the gaits shall not be tolerated.

**a.** Each show in which gaited mules are exhibited in 7 or more classes must have present a Designated Qualified Person, DQP, carded with the Horse Protection Commission or other gaited mule associations to detect and diagnose a mule which has been sore and to otherwise inspect mules for the purpose of enforcing the NASMA humane rules. Any ruling in shows in which a DQP inspects mules, the DQP's decision is final and not subject to protest or grievance.

**b.** Each show in which gaited mules are exhibited in 6 or less classes the judge and/or a veterinarian has the authority to excuse any animal that, according to their professional opinion, appears to be sore.

**c.** Handlers must be able to lift the foot of the mule to be inspected.

**d.** Show Management has the right to affix additional charges per class to cover the cost of the inspection. This charge cannot exceed \$10 per class.

**3. AGE DIVISIONS:** Gaited Mule classes are divided into age groups designated by 4 years and younger and 5 years and older. The age divisions for Stock Mules designated by Junior (5 years and under) and Senior Mule (6 years and over) classifications do not apply to Gaited Mules.

**4.** Should classes be offered for breeding jacks, no youth may show a jack.

**5. SHOW APPROVAL** procedures can be found in Section 113 and Section 114 B. of this NASMA rule book.

**6. AGE OF MULES:** All Gaited Mule and donkey ages are measured from January 1 to December 31. (i.e. A mule born in

April 2000 will begin its yearling year on January 1, 2001, two-year-old year in January 2002 and so on.)

- a. Two year old mules and donkeys may not be shown in any under saddle or driving class until after June 1 of their two year old year as determined on January 1.
- b. A Gaited Mule four (4) years and younger must be determined so by NASMA Registration or mouthing by a licensed veterinarian.
  - (1) Gaited mules may be mouthed at time of birth or any time there after to determine their eligibility for 4 and Under classes.
  - (2) A veterinarian certificate must be obtained at time of mouthing stating the date examination.
- c. 4 and Under Gaited Mules may show up in the same class offered in Five and Over, but Five and Over Gaited Mules may not show down in 4 and Under Gaited Mule Classes. 4 and Under Gaited Mules entered in Five and Over designated age classes in a show, must compete only in Five and Over designated age classes in that show.
- d. If a 4 and Under Gaited Mule is entered in a Five and Over Gaited Mule class that mule must remain in Five and Over Gaited Mule class for all shows for the rest of that calendar year, regardless of ownership.
- e. Any owner found to be falsely entering an older mule in a younger age division is subject to disciplinary action and will forfeit all points earned in that age classification.

#### **F. WALKING MULE GAITS**

1. FLAT WALK is a true, bold, and four-cornered, with fore legs moving straight in an elevated arc, and with a pronounced and cadenced head motion. The rear legs should follow through close to the ground, comfortable and over striding the front tracks. Stiff legged front or rear leg motion and irregular gait, especially when entering the ring, are typical of the movement of a sore mule and the judge must immediately excuse any mule exhibiting this type of motion from the ring.

2. RUNNING WALK is the same general motion as the flat walk, but with additional speed. The mule shall exhibit a smooth gliding, overstepping, four cornered gait with greater stride and accelerated head motion. The running walk should be a free and easy gait. Mules exhibiting an exaggerated, hesitating way of going, are not in form. Twisting the hocks or stiff-legged rear leg motion shall also be considered a deviation from the true running walk and a mule exhibiting these ways of going should be penalized.

3. CANTER is to be smooth and straight on both leads, not walling behind, but cantering on both ends with a rolling, rocking chair motion, comfortably in hand. Exaggerated "pumping" of the mule at the canter is not considered good form.

4. Judging Considerations- The Walking Mule should move freely in each gait and proceed in a smooth fluid, rhythmic manner. At all gaits, the mule should be flexed at the poll with muzzle slightly tucked. Stiff front or rear leg motion, stumbling bucking knees, lack of rhythmic timing, pointing, or favoring a particular leg, necessity for excessive pumping or bumping of the mule, or any tendency to rack, pace, or other deviation from the true walk are not considered good form and shall be penalized in judging.

#### **G. RACKING MULE GAITS**

1. SHOW WALK is a smooth collected, showy four-beat gait

2. SLOW RACK is a relaxed four beat gait showing style and grace.

3. Fast Rack shows the same style and action as the Slow Rack but with speed. Form should not be sacrificed for speed.

4. STYLE RACK is an accelerated version of the slow rack

emphasizing showiness and pride.

**5. Judging considerations-** In each of the first three gaits the Racking Mule must be collected and presented well, and the rider must be relaxed and smooth in the saddle. At no time should the mule exemplify a gait with animated hock action. The Racking Mule must exhibit good conformation and be free of blemishes and unsoundness. The Racking Mule should not exhibit an exaggerated head nod in the Slow Rack or Fast Rack. It should not exhibit an exaggerated hock action with the rear legs, but its stride should be long and natural. The front leg action should exhibit a curved rolling motion rather than the legs following a straight line commonly termed 'pitching or pointing'.

#### **H. GAITS OTHER THAN WALKING AND RACKING**

All mules must exhibit a saddle gait other than a trot, running walk or a rack. This would include those mules who exhibit a foxtrot, paso fino gait, single foot, stepping pace. Classes should be divided into slow gait & fast gait or slow gait & favorite gait.

**I. GAITED MULE CLASSES:** All the following classes, including the Walking Mule, Racking Mule and Gaited Mule classes can again be divided into Amateur, Youth, Ladies, Gentlemen's Amateur Ladies, Amateur Gentlemen's or open classes. In addition, it is recommended that class lists specify Western or Saddle Seat tack and attire in each class.

#### **1. WALKING MULE DIVISION –**

##### **a. 4 years and Younger Walking Mule Class Two Options:**

- (1) Mules perform two gaits: the flat walk and the running walk both directions of the arena Mules to be backed at the judge's discretion.
- (2) Mules perform three gaits: the flat walk, the running walk and canter both directions of the arena Mules to be backed at the judge's discretion.
- (3) Exhibitors are expected to show in Saddle Seat attire unless specified on the class list. To increase entries, the Show Secretary may choose to allow both types of attire and tack.

##### **b. 5 years and Older Walking Mule Class: Two Options**

- (1) Mules perform two gaits: the flat walk and the running walk both directions of the arena Mules to be backed at the judge's discretion.
- (2) Mules perform three gaits: the flat walk, the running walk and canter both directions of the arena Mules to be backed at the judge's discretion.
- (3) Exhibitors are expected to show in Saddle Seat attire unless specified on the class list. To increase entries, the Show Secretary may choose to allow both types of attire and tack.

##### **c. OPEN GRAND CHAMPION Tennessee Walking Mule:**

- (1) This class may be offered at any show in which Gaited Mule classes are offered. If offered at a NASMA World Champion Show, the title conferred would be NASMA World Champion Tennessee Walking Mule or World Champion Tennessee Walking Mule.
- (2) Open to any age mule or rider.
- (3) Winner is designated as the Open Grand Champion Tennessee Walking Mule of that show.

#### **2. RACKING MULE CLASSES:**

**a. Style Racking:** for any age or sex racking mule. Mules will be asked for two gaits, slow rack and the style rack, both directions of the arena. The style rack should show more animation and speed than the slow rack.

**b. Speed Racking:** mule to perform three gaits, the slow rack, the show rack and the speed rack both directions of the arena. Credit shall be given to the most consistent mule that shows excessive speed. A mule that breaks gait shall be

penalized.

- c. **Racking Mule Class:** Mules to perform two gaits, the slow rack and the show rack. Entries may be shown in Saddle Seat or Western attire at the discretion of the Show Secretary who must specify on the class description. Exhibitors are expected to show in Saddle Seat attire unless specified on the class list. To increase entries, the Show Secretary may choose to allow both types of attire and tack.

### **3. GAITED MULE CLASSES:**

- a. **GAITED MULE ENGLISH TRAIL PLEASURE:** for any age mule or any type of gaited mule, to be shown in Saddle Seat attire and tack and can perform two or three gaits including slow gait, favorite gait and the canter. Class description must indicate if this is a two or three gaited class. The mule should be ridden on a looser rein and display a smooth ground covering stride that is suitable for the trail. The mule should easily turn to the outside of the ring when asked to reverse.

- b. **GAITED MULE WESTERN TRAIL PLEASURE:** for any age mule or any type of gaited mule, to be shown in Western attire and tack. If the mule is not a green mule or is over the age of 4 and is being shown with a shanked bit, it must be shown with one hand on the reins and no cavasson. If the mule being shown in a snaffle two hands shall be used on the reins. This class can call for two or three gaits including the slow gait, favorite gait and canter. The class description must indicate if this is a two or three gait class. The mule should be ridden on a looser rein and display a smooth ground covering stride that is suitable for the trail. The mule should easily turn to the outside of the ring when asked to reverse.

- c. **GAITED MULEMANSHIP/EQUITATION:**

- (1) In the Equitation Division, the exhibitor, as opposed to the mule, is judged. Exhibitors are judged on their seat, hands, and their ability as it relates to the performance of the mule, appointments of the mule with the rider, ring showmanship, and overall presentation.

- (2) A class designed to evaluate the rider's ability to execute a set of maneuvers prescribed by the judge with precision and smoothness while exhibiting poise and confidence and maintaining a balanced, functional and fundamental correct body position. The ideal mulemanship pattern is extremely precise with the rider and animal working in complete unison, executing each maneuver with subtle aids and cues. The pattern may include, but should not be limited to the following maneuvers: gait a serpentine without breaking at the slow gait or favorite gait; perform a figure eight at the low gait or favorite gait; be able to track a straight line in a gait; stop when asked; back on command; canter and break to a slow gait without trotting.

- (3) Show management must identify the class as English or Western.

- d. **GAITED OBSTACLE TRAIL:**

- (1) It is suggested that this class be divided into youth and adult classes where there are sufficient entries. The judge may grade each obstacle subtracting points for faults, refusals, excessive time, etc. Plus and minus points may also be used for each obstacle. The judge should request a contestant move on to the next obstacle if too much time is spent on one obstacle.

- (2) A minimum of six obstacles will be used, three of which are mandatory and at least three others selected from the approved list. See Section 174 Trail K. in this rule book

for details regarding obstacles.

- (a) Mandatory Obstacles:
  - ii) GATE
  - iii) BRIDGE
  - iv) BACK THROUGH
- (b) Additional Obstacles
  - ii) Water hazard
  - iii) Simulated water hazard
  - iv) Serpentine obstacles at a walk or a gait.
  - v) Carry an object
  - vi) Ride over at least four logs or poles.
  - vii) Put on and remove a slicker.
  - viii) Side pass (may be elevated to a 12" maximum.)
  - ix) Box
  - x) Mail Box
  - xi) Lime Circle –
  - xii) Drag or Pull
- (c) Prohibited Trail Obstacles:
  - ii) Tires
  - iii) Live animals
  - iv) Pvc pipe
  - v) Jumps
  - vi) Rocking or moving bridges
  - vii) Water box with floating or moving parts
  - viii) Flames, dry ice, fire extinguisher
  - ix) Logs or poles elevated in a manner that permits such to roll.
  - x) Ground Tie
  - xi) Dismounting

(3) The course must be designed to require each mule to demonstrate walk, trot and gait somewhere between the obstacles as part of the working course.

(4) Final consideration of the judge will include quality and smoothness of performance of the mule and neatness and ability of exhibitor. The ideal trail mule will negotiate the course with surefootedness; looks at the obstacles, but does not hesitate, yet does not rush along the course; moves willingly without excessive urging of exhibitor. Mule should show willingness to stand quietly on the bridge and not rush off. At the gate, the obstacle is not complete unless the gate is closed and should be judged accordingly. Mule should position himself at all times to enable the exhibitor to keep a hand on the gate until the gate is closed.

(5) Entry may be either English or Western, but not a combination of both. Western exhibitor must hold reins in one hand (the exception being a mule four (4) or under wearing a bosal or ring snaffle) and should not be changed during the performance except while working the gate, if necessary. English entries may be ridden with both hands on the reins. A time limit may be set for the course; however, the time itself will have no bearing on the final placement except as a limit for course completion. Any type hackamore is not permitted with the exception of a bosal.

#### **e. GAITED MULES AT HALTER: HALTER DIVISION**

(1) Halter class entries are presented in hand, in either a halter or bridle as dictated by the specific class requirements

(2) Attire for this class may be either English or Western, but not a combination of both, and must be clean and neat.

(3) Whips not to exceed four (4) feet in length including snapper are permitted for use by exhibitors, unless shown in western. Whips are not permitted in Western

showmanship.

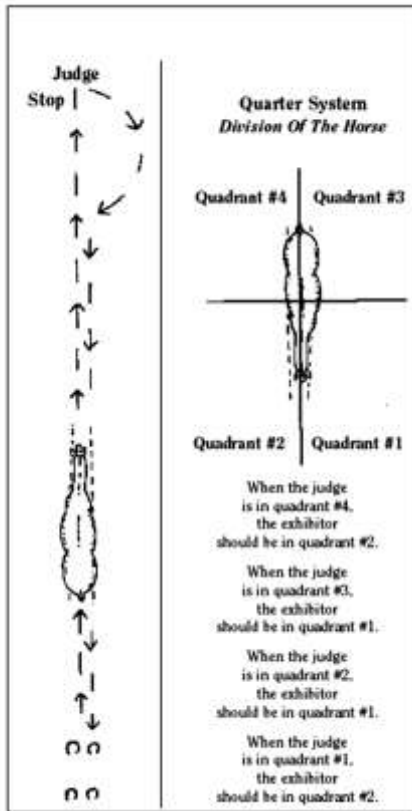

**f. SHOWMANSHIP AT HALTER** Enter the ring in the direction indicated by the ring steward and walk until the judge requests that the mules line up for inspection. Walk on the mules left side, holding the lead shank in the right hand, near halter. The remaining portion of the lead shank will be held neatly and safely in left hand. A tightly coiled or rolled lead shank or one with fingers inserted or laced through the coils, will be considered a fault in showmanship. Animal should lead readily at a walk and running walk.

- (1) After judge has lined up the class, each exhibitor will be requested to move his mule individually. When moving the mule, the exhibitor should be sure that the judge gets a clear, unobstructed view of the mule's action. Allow the mule sufficient lead so that he can move freely in a straight line with his head carried at a height appropriate to his conformation. Lead
- (2) When posing the mule, the exhibitor should stand toward the front facing the mule with his toes pointed toward the mule's eye or neck. The exhibitor should not stand directly in front of the mule but should always stand in a position where he can keep an eye on the judge. With the quarter system, the mule is divided into four sections by drawing one imaginary line down his back and another across his middle. When the judge is looking at either hindquarter of the mule, the exhibitor stays on the same side as the judge, with his toes pointed toward the mule's eye or neck. When the judge looks at either front quarter, the exhibitor crosses to the opposite side of the mule.

When posing the mule, do most of the showing with the lead shank. The exhibitor should not touch the mule with his hand, never change hands on the lead shank or kick the mule's leg into position.

- (3) The exhibitor should not crowd the entry next to them in a side by side position. The exhibitor should not crowd the entry in front when lined up head to tail.
- (4) The exhibitor should leave a mule's length between them and the next entry.
- (5) Poise, Alertness and Merits Keep alert and be aware of the position of the judge at all times. Do not be distracted by persons or things outside the ring.
- (6) Class to be judged 50% on conformation and 50% on gait. The mules will be exhibited at a slow gait both ways of the area before being brought to the center for individual inspection. The ideal gaited mule should be well proportioned, having a long neck that comes out of the shoulder at the angle of 45 to 55 degrees, short back, long sloping croup and hind legs should have some set to the hock which will enable a gaited mule to stride under himself. When tracking, the mule should carry his head above the withers and his fore legs should mover from the shoulder allowing extension and breaking in the foreleg and the hind legs should step over the front foot stride. When tracking the mule should move very loose and free. The handlers should wear Western or Saddle Seat attire and the halter or bridle should match the exhibitor's attire.

**g. DRIVING CLASSES:** Any of the driving classes found in the Driving Section of this rule book may be offered for the Gaited Mule in harness adhering to the Driving Tack rules listed above.

**J. TIME OUTS:** Time Outs interrupt the show, therefore unauthorized time outs will not be permitted.

1. A rider desiring a time out will ride to the center of the arena, remain mounted and request it of the Judge. The Judge will ascertain the reason for the time-out and either grant or deny the request.

2. After an exhibitor pulls into the center, he/she must obtain a time-out before dismounting. Failure to do so shall require the Judge to excuse the entry; the Judge has no discretion in this regard. Further, the entrance of a trainer or an assistant into the show ring before a time-out is granted shall require the Judge to excuse the entry. The sole exception to this rule shall be a mule and/or rider in immediate danger of injury in the opinion of the Judges

3. If the Judge grants a time-out, mules on the rail will go at ease, and a groom or farrier will be ordered in as required. The rider may then dismount. Riders granted a timeout may not make adjustments to any equipment other than that for which the time-out was authorized except for adjustment as they would make while mounted.

4. Riders at ease on the rail during time-outs may make such adjustments as they can make while mounted, but assistance over the rail is not permitted; physical assistance (touching the mule) is not permitted and mule must be excused.

5. If the Judge finds the reason for the time-out not valid, he/she must order the entry back to the rail immediately.

6. Time-outs may be granted by the Judge for replacement of shoes, for replacement of broken equipment, or in other instances where the Judge finds reasons. However, time-outs for adjustments of equipment, such as curb chains, bridles are not allowed.

7. A total of ten minutes in aggregate shall be allowed for each

entry for authorized time-outs, but no more than two time-outs per class.

**K. WORKOUTS:** All mules chosen for a workout must be worked both ways of the arena each gait asked for by the Judge. A Judge shall not place any entry in a workout unless the entry has performed all required gaits both ways of the arena in the initial performance. Any Judge ignoring this rule shall have subjected himself/herself to disciplinary action. Workouts shall be judges as a separate class. Any and all mules performing in the arena must be considered for first place.

**L. FALLS:**

1. A rider is considered to have fallen when he/she is separated from a mule that has not fallen in such a way as to necessitate re-mounting or vaulting into the saddle.

2. A mule is considered to have fall when the shoulder and haunch on the same side have touched the ground.

3. The fall of a mule and/or rider shall not disqualify the entry, unless due to bad manners of the mule or unless the safety of the rider is threatened.

**M. UNRULY MULES:** Mules being unruly, rearing up, balking, running off, or leaving the arena must be excused.

**N. RIDER CLASS DIVISIONS**

1. **Open Classes:** classes are open to all Rider/Exhibitor Divisions.

2. **Amateur Classes:**

a. Amateur is any rider nineteen years old and older on January 1 of the calendar year of the show

b. Amateurs must hold a current NASMA Amateur card.

c. Amateur mules must be owned by the Amateur or the Amateur's immediate family. See Section 147 E.

d. A NASMA Amateur card or NASMA registration papers must accompany the amateur's entry form.

e. NASMA Amateur riders riding a mule they own are permitted to show in open classes.

f. Class description must specify for Amateur exhibitors only and can be further broken down into Amateur Ladies Class as well as Amateur Gentlemen's class. All above mentioned classes, including the Walking, Racking and gaited classes mat be held for Amateur exhibitors.

3. **Youth Classes** is defined as a rider who is eighteen years and younger on January 1 of the calendar year of the show. A Youth must be in control of the animal he/she is handling at all times. The judge should and will excuse any entry that is not in control of his/her mule. No youth may show a jack in any event.

**O. GRIEVANCES/PROTESTS**

1. The Grievance Committee made up of the NASMA Grievance Committee Chair, the NASMA Gaited Committee shall have sole authority to investigate possible or alleged violations of any by law, rule or regulation of the Association. This Grievance Committee will gather all needed information, the \$100.00 protest fee, and substantiate the need for further investigation, and then will transfer the documentation to the Board of Directors with no names mentioned. See 101 Standing Committees,

2. The person filing the protest must be a NASMA member.

3. If a member of the Grievance Committee is involved in any protest, she/he should be removed from the voting procedure and an alternate member should be appointed to serve temporarily on the Gaited Grievance Committee.

4. Violations concerning the following will NOT to be addressed by the Grievance Committee.

a. Judge issues which are handled through the Judge's Committee

b. Show ring lay out

- c. Timer problems
  - d. Disagreements about disqualifications. (In shows in which a DQP inspects mules, the DQP's decision is final and not subject to protest or grievance.)
  - 5. The protest must be filed in writing citing the specific rule infraction, signed by the protesting member(s) and delivered to any member of the Grievance Committee within 48 hours of the time of the cause of the protest.
  - 6. The protest must be accompanied by a \$100.00 fee by cash or check which shall be forfeited if the protest is not sustained.
- P. Suspended Individuals:** Any person receiving disciplinary suspension from NASMA or any other gaited equine association will be refused entry into NASMA gaited mule classes for the period of their suspension.

## **Showmanship/Equitation Mulemanship/Donkeymanship**

These classes are judged on the exhibitor's ability to fit and show the mule or donkey. These classes have proven to be highly competitive and advocate that exhibitors learn the proper way to present their animals to the judge and the public. The use of markers helps standardize patterns and guide exhibitors, but they also increase the degree of difficulty somewhat, so their placement should be carefully planned and indicated in the posted pattern and their placement in the arena well supervised. All patterns must be posted by the judge at least one hour before the beginning of the class, or may be posted the first day of a multi-day show.

### **189 Showmanship at Halter**

**A. Showmanship at Halter** shall be judged strictly on the exhibitor's ability to fit and show a mule or donkey at halter. The animal is merely a prop to demonstrate the ability and preparation of the exhibitor. The ideal showmanship performance consists of a poised, confident, neatly attired exhibitor leading a well groomed and conditioned animal that quickly and efficiently performs the requested pattern with promptness, smoothness, and precision. The showmanship class is not another halter class and should not be judged as such.

**B. Posting of Patterns:** It is mandatory that the judge post the pattern he/she will ask for at least one hour prior to the commencing of the class; however, if the judge chooses to bring back exhibitors for consideration of final placing, the finals pattern need not be posted.

**C. Class Routine:** All exhibitors may enter the arena and then work individually or each exhibitor may be worked from the gate individually. When exhibitors are worked individually from the gate, a working order is required. The following maneuvers are considered acceptable: Lead the animal at a walk, jog, trot, or extended trot, or back in a straight or curved line, or a combination of straight and curved lines; stop; and turn 90 (1/4), 180 (1/2), 270 (3/4), 360 (full turn) degrees or any combination or multiple of these turns. The judge must have the exhibitors set the animal up squarely for inspection sometime during the class.

**D. Scoring:** The scoring system suggested for NASMA showmanship classes is based on a scale of 0 to 20, with 20 denoting an excellent performance and turnout. Point allowances are listed below.

**APPEARANCE OF THE MULE/DONKEY:** 5 points

**1. Condition and thriftiness:**

- a. The animal's body condition and overall fitness should be assessed

## **2. Grooming:**

- a.** The hair coat should be clean and well groomed.
- b.** The mane, tail, foretop and wither tufts should be free of tangles and clean. It is prohibited to use any ornaments on the animal. Manes, tails, foretops and wither tufts may be English braided or manes may be Western banded if the exhibitor desires.
- c.** Hooves should be trimmed properly. If shod, shoes must fit properly and clinches should be neat. Hooves must be clean and may be painted or shown naturally.

## **3. Trimming:**

- a.** Manes may be roached.
- b.** Inside of ears may be clipped.
- c.** Long hair on jaw, legs and pasterns should be clipped.

## **4. Tack:**

- a.** Tack should be neat, clean in good repair. Proper fit of the halter is imperative. Silver halters should not count over a well fitted, clean and functional halter

### **APPEARANCE OF EXHIBITOR: 5 points**

- 1.** Clothes and person are to be neat and clean.
- 2.** Appropriate western attire must be worn.

### **LEADING AND POSING ANIMAL: 5 points**

#### **1. Leading**

- a.** The exhibitor must lead on the animals left side holding the lead shank in the right hand near the halter with the tail of the lead loosely coiled in the left hand. It is preferable that the exhibitor's hand not be on the snap or chain portion of the lead continuously. The excess lead should never be tightly coiled, rolled, or folded. When leading, the exhibitor should be positioned between the eye and mid-point of the animal's neck, referred to as the leading position.

- b.** The position of the exhibitor when executing a turn to the right is the same as the leading position except that the exhibitor should turn and face toward the animal's head and have the animal move away from them to the right.

- c.** When executing a back, the exhibitor should turn from the leading position to face toward the rear of the animal with the right hand extended across the exhibitor's chest and walk forward beside the animal with the animal moving backward.

- d.** Leading, backing, turning and initiating the set up should be performed from the left side of the animal. At no time should the exhibitor ever stand directly in front of the animal. The exhibitor should not touch the animal with their hands or feet, or visibly cue the animal by pointing their feet at the animal during the set up.

#### **2. Posing**

- a.** When setting the animal up for inspection, the exhibitor should stand angled toward the animal in a position between the animal's eye and muzzle, and should never leave the head of the animal. The exhibitor should maintain a position that is safe for them and the judge. The position of the exhibitor should not obstruct the judge's view of the animal, and should allow the exhibitor to maintain awareness of the judge's position at all times. The exhibitor should not crowd other exhibitors when setting up side by side or head to tail. When moving around the animal, the exhibitor should change sides in front of the animal with minimal steps and should assume the same position on the right side of the animal that they had on the left side.

- b.** the animal should be set up quickly with the feet squarely underneath the body. The exhibitor does not have to re-set an animal that stops square.

- c.** Exhibitors should be poised, confident, courteous, and genuinely sportsmanlike at all times, quickly recognizing and correcting faults in the positioning of the animal. He/she should

be business-like, stand and move in a straight, natural, and upright manner, and avoid excessive, unnatural, or animated body positions.

**PERFORMANCE** 5 points

a. The exhibitor should perform the work accurately, precisely, smoothly and with a reasonable amount of speed. The animal should lead, stop, back, turn and set up willingly, briskly and readily with minimal visible or audible cueing. Failure to follow prescribed pattern, knocking over or working on the wrong side of the cones, or severe disobedience will not result in a disqualification, but should be penalized severely and the exhibitor should not be placed above an exhibitor that completes the pattern correctly. Excessive schooling or training, willful abuse, or loss of control of the animal by the exhibitor shall be cause for disqualification.

b. The animal should be led directly to and away from the judge in a straight line and track briskly and freely at the prescribed gait. The animal's head and neck should be straight and in line with the body.

c. The stop should be straight. prompt, smooth and responsive with the animal's body remaining straight

d. The animal should back up readily with the head, neck and body straight.

e. When turning the animal to the left 90 degrees or less, the animal should be turned to the left. On turns greater than 90 degrees, the ideal turn consists of the animal pivoting on the right hind leg, while stepping across and in front of the right front leg with the left front leg. An exhibitor shall not be penalized if their animal performs a pivot on the left hind leg, but an exhibitor whose animal performs the pivot correctly should receive more credit.

## **The Quarter Method ®**

The following suggested guidelines of movement are meant to serve as an illustration of movement around the animal while showing in showmanship at halter and are for the exhibitor's information. Imaginary lines bisect the animal into four equal parts as seen in the following figure. (Note: the quadrants will be numbered I, II, III, IV for each of identification.) One line runs across the animal just behind the withers. The other imaginary line runs from head to tail. When the judge is in I, the handler should be in IV. As the judge moves to II, the handler should move to I. When the judge moves to III, the handler moves to IV. As the judge moves up the animal to IV, the Handler returns once more to I. This method is based on safety as the handler can keep the animals hindquarters from swinging toward the judge should the animal become fractious.

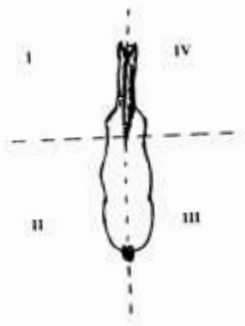

## 190 Hunt Seat Equitation

**A.** The hunt seat equitation class is an evaluation based on the ability of a rider to perform various maneuvers in harmony with his/her animal. The communication between animal and rider through subtle cues and aids should not be obvious. Equitation is judged on the rider and his/her effect on the animal. It provides a base for a natural progression to over fence classes.

### **B. Class Routine:**

1. Each rider will work individually.
2. It is mandatory that the judge post the pattern at least one hour prior to the start of the class. The pattern must include a trot and canter. Patterns may include any of the following maneuvers: Walk, sitting trot, extended trot, posting trot, canter, circles, figure 8, halt, back, side pass, address reins, change of diagonal, turn on the haunches or forehand, leg yield, simple change of lead, hand gallop, counter canter, drop or pick up irons. The animal's gaits are to be ridden at the same cadence and speed as one would ride in a hunter under saddle class.

### **C. Judging Considerations-Position of Rider:**

1. Hands should be over and in front of animal's withers, knuckles thirty degrees inside the vertical, hands slightly apart and making a straight line from animal's mouth to rider's elbow. Method of holding reins is optional, and bight of reins may fall on either side. However, all reins must be picked up at the same time. Failure to maintain light contact, or riding with draped reins is a fault in hunt seat equitation.
2. The eyes should be up and shoulders back. Toes should be at an angle best suited to rider's conformation; heels down, calf of leg in contact with animal. Iron should be on the ball of the foot and must not be tied to the girth.
3. At the walk, sitting trot and canter, the body should remain vertical with a secure seat and leg: at the posting trot the upper body should be inclined approximately 20 degrees in front of the vertical; at the hand gallop the rider should ride in two-point position, with the upper body approximately 30 degrees in front of the vertical, and the riders weight off of the animals back.

## 191 Western

### **Mulemanship/ Donkeymanship**

**A.** The western Mulemanship/Donkeymanship class is designed to evaluate the rider's ability to execute a set of maneuvers prescribed by the judge with precision and smoothness while exhibiting poise and confidence, and maintaining a balanced, functional, and fundamentally correct body position. The ideal Mulemanship/Donkeymanship pattern is extremely precise with the rider and animal working in complete unison, executing each maneuver with subtle aids and cues.

### **B. Class Routine:**

1. All exhibitors must enter the ring and then work individually or each exhibitor may be worked from the gate individually. The following maneuvers are acceptable in a pattern: walk, jog, trot, extended trot, lope, or extended lope in a straight line, curved line, serpentine, circle, or figure 8, or combination of these gaits and maneuvers; stop; back in a straight or curved line; turn or pivot, including spins and rollbacks on the haunches and/or on the forehand; sidepass, two track, or leg yield; simple change of lead; counter canter or ride without stirrups. Judges should not ask exhibitors to mount or dismount.

### **C. Judging Considerations-Position of Rider:**

**1. Seat and legs** - The exhibitor should appear natural in the seat and ride with a balanced, functional, and correct position regardless of the maneuver or gait being performed. The rider should sit in the center of the saddle with legs hanging to form a straight vertical line, from the ear, dropping down through the center of the shoulder and hip, touching the back of the heel. stirrup length should allow heels to be lower than toes, with a slight bend in knee and the lower leg directly beneath the knee. Body should always appear comfortable, relaxed and flexible, and back should be nearly flat. The shoulders should be back, level and square. Stiff and/or arched lower back should be avoided. Feet may be placed home in the stirrup, with boot heel touching the stirrup, or may be placed with ball of foot in the stirrup. Riding with toes only in stirrup will be penalized.

**2. Hands** - Both hands and arms should be held in a relaxed easy manner, with shoulder back and down, and upper arm in a straight line with the body. The arm holding the reins bent at elbow forming a straight line from elbow to the animal's mouth. The free hand and arm may be carried bent at the elbow in a similar position as the rein hand, or straight down at the rider's side. When using a romal, the rider's off hand shall be around the romal with at least 16 inches of rein between the hands. Wrists are to be kept straight and relaxed, with thumb on top and fingers closed around the reins. One finger between the reins is permitted when using split reins, but not the romal. Some movement of arm is permissible, but excessive pumping will be penalized. Reins are to be carried immediately above or slightly in front of the saddle horn. Only one hand is to be used for reining, and hand shall not be changed. (EXCEPTION: animals being shown with a hackamore or snaffle bit.) Reins should be carried so as to have light contact with the animal's mouth and at no time shall reins be carried more than a slight hand movement from making contact with the bit. Excessively tight or loose reins will be penalized.

**3.** The rider's head should be held with the chin level and the eyes forward, and may be directed slightly toward the direction of travel.

**4.** Rider should sit both the jog and extended jog and remain seated at the lope. The rider should maintain a vertical and secure position at all gaits. All movements of mule should be governed by the use of imperceptible aids. Exaggerated shifting of the rider's weight is not desirable.

## SPECIALTY CLASSES

### 192 Coon Jump

**A. Exhibitors:** The Coon Jump is open to all ages of exhibitors but any youth exhibitor must have a responsible adult in the ring during the class. This adult may not physically assist except in case of an uncontrollable incident and any assistance will terminate further competition from that youth exhibitor.

**B. Attire:** Western attire or anything a real coon hunter might wear is appropriate. Tennis shoes are not permitted. Some type of hat or cap is required.

**C. Equipment:** Freestanding jump will have a single, horizontal, freely sliding crossbar which will be supported by wooden dowels no more than 1/4" in diameter which will break and drop the crossbar if the animal fails to make the jump. Horizontal width of the jump will be a minimum of 8' feet. Holes for dowel pins can be at 1" or 2" increments with the bottom hole 30" inches from the ground and the top hole at a minimum of 72".

**D. Class Division:** May have up to 3 height classes

1. up to 48"
2. 48.01" to 54"
3. 54.01" and up

**If only two height classes are offered they should be**

4. up to 50"
5. 50.01" and up

**E. Size of Box:** Animals in the small height class will jump from inside a 10' marked box. Animals in the larger height classes will jump from inside a 12' marked box.

**F. Size of Initial Jump:** Initial jump will be determined by the chest height of the smallest animal in the class. Initial jump must be cleared to qualify for placing.

**G. Timing:** Each jumping attempt is to be timed by a stopwatch with a required backup stopwatch. Time starts when the first hoof touches the ground in the box.

**H. Stop before Jumping:** After entering the marked box area, the animal must stop before jumping.

**I. Attempts:** Two attempts may be made at each height in a maximum of 60 seconds. Time is stopped only to replace pins. Pins should be checked between jumps.

Attempts will be considered:

1. If animal steps out of box
2. If animal breaks pin or pins
3. If animal pushes jumps more than 2"

**J. Handler:** Handler may stand to either side of box, but must hold reins or lead rope in hands at all times. Failure to do so is a disqualification. Handler is not to hold or touch the jump in any way, except for placing blanket or cover before animal begins attempt. Holding cover, jump bar, standard or pin while competing is an immediate disqualification.

**K. Covering Jump:** A blanket or cover may be used over the jump if the handler desires.

**L. Abuse:** No physical abuse or force of the animal will be allowed.

**M. Ties:** Should two or more mules tie for the height, the animal which clears the jump in one attempt will be the winner, regardless of time. If both animals clear the jump on the same attempt (first or second), the animal with the shortest time will be the winner. If none of the animals have jumped a particular height, then the jump will be lowered until one or more jumps. If two or more animals have still not jumped the same height, the one making the most attempts places higher.

## 193 Costume Classes

**A.** Animals are to be shown in some costume that is authentic in some country, work of literature or art, or in some occupation or sport, past or present.

**B.** Costume to be judged on originality, authenticity and audience appeal.

**C.** Each entry in this class must be accompanied by a typed or legibly written description to be read by the announcer. The entire costume presentation should be limited to one minute. The written description and any taped music should be given to the show office at a time specified in the show flyer or announced at the show so management will have time to read and assemble the information to exhibitor's best interest.

**D.** Show management will reserve the right to rule on music and dress which may be inappropriate or offensive to the spirit and nature of the show.

## 194 Freestyle Reining

**A.** Reining maneuvers originated from moves that a cow mule must use in performing its duties and have been refined to the high level of competition existing today. Freestyle Reining not only

provides an opportunity to use these maneuvers creatively, but also expand them to music by means of choreography. Riders are encouraged to use musical scores which permit them to show the athletic ability of the mule in a crowd appealing way. NASMA rules will apply except where the following rules preempt

**B. Required Maneuvers:** Required Maneuvers will be defined as followed:

1. A minimum of 4 consecutive spins to the right.
2. A minimum of 4 consecutive spins to the left.
3. A minimum of 3 stops
4. A minimum of 1 lead change at the canter from right to left
5. A minimum of 1 lead change at the canter from left to right.

**C.** Exhibitors will only be judged astride

**D.** Use of Two Hands: Exhibitors are allowed to use two hands (as well as one or no hands) and any bit approved for by NASMA rule book, including snaffle bits and hackamores approved for use in Junior Mule classes.

**E.** No Score: Failure to perform all the required maneuvers or failure to complete the pattern within the time limit will result in no score.

**F. Credit:** Additional maneuvers such as rollbacks, backups, speed variations, and non-classical reining maneuvers such as half pass and side pass are appropriate in Freestyle and shall be given appropriate credit. Additional repetitions of required maneuvers are appropriate, but will only add or subtract from the existing scores already given for the required maneuvers, not as additional scores.

**G. Time Limit:** Time limit is a maximum of 4 minutes including any introductions. The time limit will be from the beginning of the music or from the beginning of the introduction (whichever is first) and will end with the music.

**H. Costumes:** Costumes are permitted. but not required. Emphasis is placed on performing the reining maneuvers to music.

**I. Props:** Props are permitted but at no time may hinder the judge's view of the mule. The use of props will not add to the score.

**J. Judging Considerations** - The judging method to be used for the Freestyle will allow for the assessment of an overall score following the ride. This overall score will be based on the technical merit of required maneuvers and the quality of non required maneuvers as they add or detract from the overall impression of the ride.

1. Each rider will be scored from 0 to infinity with 70 denoting an average score
2. Definition of required maneuvers: As listed previously
3. Definition of transitional maneuvers: Those maneuvers which allow a mule to move from one part of the pattern to another which are not specifically designated as required including but not limited to such maneuvers as trots and transitions between gaits.
4. Definition of Non Required Maneuvers: Those maneuvers which are not required but demonstrate creative moves displaying control, increased degree of difficulty, athletic ability, and finesse attributed to the skill levels of a well trained reining mule.
5. If two judges are used, one judge will score the technical merit of the ride as well as one judge to score the artistic impression. Each score would bear equal weight. In case of a tie, the artistic impression judge's score would be used to break the tie.
6. Validating required maneuvers will not be the responsibility of the judges. At least one scribe will be used to

verify the required maneuvers for each mule as they are completed in the pattern.

**K. Eliminations and Invitational** may be used at the discretion of the show management and should use NASMA approved Reining Patterns. Eliminations and Invitational may be held without music or costuming, but must allow the use of either one or two hands. The emphasis in the design of any Elimination or Invitational should be on quality of competition.

**L. Freestyle Reining** may offer both Open and Non-Pro classes. Show management will reserve the right to run them concurrently or separately.

**M.** Show management will reserve the right to rule on music or dress which may be inappropriate or offensive to the spirit and nature of the show. Show management may also determine the use of special lighting.

## 195 Ladies Side Saddle

**A. Class Routine:** Animals shall enter the ring counter clockwise at a trot or jog and work both directions at the walk, trot or jog, and canter or lope. A good ground covering walk, a comfortable trot or jog, and easy flowing canter or lope are desired gaits. Mules or donkeys may be asked to halt and stand quietly on a loose rein. Animals must be brought to a walk before changing gaits. Animals are to be reversed at the walk or trot, but shall not be reversed at the lope or canter. Riders shall not be asked to dismount.

**B. Judging Considerations:** Transitions from one gait to another should be smooth and effortless. Riders with English tack and attire may sit or post the trot. Mules should stand quietly and back readily if requested by the judge.

1. The side saddle mule should have gaits that give the distinct impression that it is a comfortable mount to ride.

2. Manners and suitability of purpose shall be emphasized.

3. Class to be judged as 75% on Performance, manners and way of going, 25 % on Appointments and overall appearance.

**C. Appointments:** Safety is of the utmost importance in both tack and attire. Judges should penalize exhibitors not conforming to good safety practices. All sidesaddles are required to be in safe rideable condition, whether in original condition or renovated.

Leaping pommels are required for saddles. Balance straps are recommended on appropriate side saddles.

1. Tack- Mule should be tacked up in appropriate side saddle of either an English or Western Style. Bridles should be appropriate to style of the saddle and only regulation bits may be used. No martingales or tie downs allowed. Appropriate whip or crop may be carried. A spur is optional. Formal hunt seat riders will need proper appointments.

2. Attire- English (formal and informal), hunt or saddle seat, or Western (western consisting of a long sleeve blouse or shirt, a coat or vest, skirt or apron, hat and boots).

**For more information** on appointments, tack and attire, contact the World Sidesaddle Federation, Inc., P0 Box 1104, Bucyrus, OH 44820. Phone or Fax 419-284-3176.

## 196 Dressage

NASMA encourages that Dressage competitions be held. Rules and regulations should be the most current American Horse Show Association "Dressage Division" rules.

**A. Bits:** Any regulation smooth snaffle bit (either two or three piece) is acceptable as are Mylar(r) type snaffles, 2 or 3 piece, are legal as long as other AHSA equipment specifications are met.

## 197 Open Mule Walk/Trot

The mule may not cross enter into another class requiring a lope with the SAME exhibitor at that show. **Bits:** Legal bit

requirements apply, although any age mule may be shown in a legal snaffle bit or bosal with 2 hands. Should the show inadvertently allow cross entry, all riding points earned by cross entries will be forfeited. Western Equipment and attire apply.

## APPENDIX

### I. DRAFT DIVISION

A) **DRAFT MULE CLASSES** Any class designated with an asterisk (\*) could also be offered as a youth class

1. Draft mules at Halter – 5 years old and younger
2. Draft mules at Halter – 6 years old and older
3. Draft Matched Pair at Halter (not eligible for Grand/Reserve Champion)
4. Pleasure Driving – single hitch\*
5. Pleasure Driving – team\*
6. Reinsmanship – single hitch\*
7. Reinsmanship – team\*
8. Unicorn Hitch
9. Four-mule Hitch
10. Six-mule Hitch
11. Eight-mule Hitch
12. Obstacle Driving – single hitch\*
13. Obstacle Driving – team\*
14. Gambler's Choice – single hitch
15. Gambler's Choice – team
16. Log skidding – single hitch
17. Log skidding – team
18. Farm Team Race
19. Heritage Driving/Antique Vehicle
20. Parade Hitch
21. Farm Team Driving

B) **General Draft Division Rules**

- 1) This division is designed to showcase the “heavy” or Draft type Mule under harness. Mules shall be safely and securely harnessed while competing in driving events. Two people are allowed on the vehicle when two or more animals are being driven or when the exhibitor is a youth. Once the vehicle has stopped, headers will be allowed.
- 2) For point accumulation in competition, each mule shall be assigned a competition number that is to be displayed when the animal is working singly. A team of two or more mules will be assigned a competition number for that team as a unit. Double points may not accrue. (Example: Bess is assigned #30 for halter, single hitch classes, etc. If Bess is hitched to Belle for a team classes, that unit of both mules is assigned a different number - #31, for example. If both Bess and Belle are hitched in a four-mule hitch with Bob and Bill, the four-mule hitch is assigned a different number - #33, for example. Bess cannot accrue points toward High Point Draft Mule under any other competition number other than #30.)
- 3) Classes may be provided for single or multiple hitches.

4) *Attire:*

- (a) *Drivers should be dressed conservatively and with respect to the vehicle being driven.*
- (b) *Period costumes are acceptable if they are in good taste*
- (c) *T-shirts, tank tops, shorts, etc are not allowed*
- (d) *Lap robes/aprons are encouraged, but not required.*
- (e) *Drivers must wear appropriate footwear*
- (f) *A hat of choice is required*
- (g) *Gloves are encouraged, but not required.*

5) *Driving Terminology*

- (a) *WALK: A natural flat foot, four beat gait. The mules should walk energetically, but calmly, with even and determined pace. Loss of forward rhythmic movement shall be penalized.*
  - (b) *TROT: A clear, but not excessive, increase in pace and lengthening of stride while remaining well balanced and showing later flexion on the turns. The steps would be as even as possible with the hind foot touching the ground in the foot prints of the fore feet. Light contact should be maintained. Excessive speed will be penalized. (NOTE: The judge may request an extended or ROAD TROT.)*
  - (c) *REIN BACK: Consists of the animal/team moving backward in an unhurried manner with the head flexed and straight, pushing the vehicle back evenly in a straight line. The driver should use quiet aids and light contact.*
  - (d) *REVERSE: Change of direction, accomplished by the mule circling off the rail or crossing the ring at a walk or trot. In single hitch, small classes at the discretion of the judge and/or show management, the reverse may be accomplished by circling off the rail to change direction. In multiple hitch and/or large classes, the reverse should be made on the diagonal at the direction of the ring steward.*
  - (e) *HALT or STOP: A complete, square stop of the animal and vehicle without veering or abruptness. At the halt, the mules should stand attentively, motionless and straight with the weight evenly distributed over all four legs and be ready to move off at the slightest indication from the driver.*
- 6) *WHIP It is recommended that an appropriate whip be carried in the vehicle. The thong on the whip must be long enough to reach the shoulder of the farthest mule, except in multiple hitches of four, six, eight, etc.*
- 7) *Outside Assistance:*
- (a) *Only the driver may handle the lines, whip or brake during a competition. The penalty for non-compliance is disqualification.*
  - (b) *No change of driver is permitted, except where specified by the class description*
  - (c) *Drivers receiving outside assistance after the judging has begun will be disqualified at*

*the judge's discretion unless that assistance has specifically been allowed (such as the use of a header.)*

**8) The Animal**

- (a) The mule(s) must be serviceably sound and must not show evidence of lameness, broken wind or impairment of vision.*
- (b) If shod, the mule(s) must be suitably shod for driving. No extended hooves, heavy shoes or toe weights will be allowed.*

**9) Harness:**

- (a) Bridles should fit snugly to prevent catching on the vehicle or other pieces of harness. A throatlatch and a noseband or cavasson is mandatory.*
- (b) Black harness is considered appropriate for painted vehicles and natural wood vehicles having black trim*
- (c) Brown harness is considered appropriate with natural wood finished vehicles trimmed in brown*
- (d) All metal furnishings should match and be secure*
- (e) Full collars are suggested, particularly for heavy vehicles*
- (f) A correctly fitted harness is essential for the comfort of the Draft Mules.*
- (g) Overchecks are prohibited in obstacle classes. Failure to comply incurs disqualification*

**10) Bits**

- (a) Snaffle bits and other types of traditional driving bits are allowed.*
- (b) Legal bits include:*
  - (1) Half cheek snaffle*
  - (2) Liverpool*
  - (3) Elbow driving*
  - (4) Bradoon overchecks*

**11) Vehicles:** *Drivers should strive to present an appropriate turnout. Appropriate indicates the balance and pleasing appearance of the combination of mule(s) and vehicle. Factors determining the above include compatible size, type and width of the mule(s) and vehicle. The way of going of the mule(s) may also affect the overall appearance.*

**12) Splitting Classes:** *Large classes may be split at the discretion of*

**13) the judge and/or show management. Size of the arena and safety are the prime considerations.**

**14) Excessive Use of Voice:** *Excessive use of voice, shouting or whistling to the mule(s) may be penalized at the judge's discretion. The driver should strive to control the mule's movement with a minimum of vocal aids. If necessary, it is permissible to talk to the mule(s) in a subdued tone of voice. Clucks for starting, "walk on", "trot", "gee", "haw" and "whoa" are the more accepted terms.*

**15) Leaving the arena:***No entry may leave the arena after judging has begun without permission from the ring steward. EXCEPTION: In the event of an accident or equipment failure which requires either medical attention or repair, the turnout*

*must leave the arena as soon as possible after notifying the ring steward. If asked to leave the arena by the ring steward, the turnout must do so as soon as possible.*

**16) Canter:** *Cantering is NOT ALLOWED in driving classes unless stated in the class description. Canter in harness will result in disqualification.*

**C) DRAFT MULE CLASSES** *Any class designated with an asterisk (\*) could also be offered as a youth class*

**1) Halter**

*(a) Draft mules at Halter – 5 years old and younger*

*(b) Draft mules at Halter – 6 years old and older*

*(c) Draft Matched Pair at Halter (not eligible for Grand/Reserve Champion)*

**1) Pleasure Driving – Single Hitch \***

*(a) Class Routine: Mule will enter the arena to the right at a Trot. entries will be exhibited both directions of the arena at the walk and normal (park) trot. At the judge's discretion, and extended (road) trot may be requested. The class will be reversed as appropriate for the class size. Entries will be asked to reinback and may be asked to halt/stop any time during the class.*

*(b) Judging Considerations: A pleasure driving class in which the entries are judged primarily on the suitability of the mule to provide pleasant drive. Animals should show quality gaits, alert expression, smooth transitions and good manners. Emphasis is 0% on performance, manners and way of going; 20% on condition and fit of harness and vehicle and 10% on neatness of turnout*

**2) Extra Work:** *Mules may be asked to do a Figure 8 or other maneuvers at the discretion of the judge.*

**3) Pleasure Driving – Team \***

*(a) Class Routine:*

*(b) Mules will enter the arena to the right at a Trot.*

*(c) Entries will be exhibited both directions of the arena at the walk and normal (park) trot. At the judge's discretion, an extended (road) trot may be requested. The class should be reversed across the diagonal length of the arena. Entries will be asked to reinback and may be asked to halt/stop at any time during the class.*

*(d) Judging Considerations: A pleasure driving class in which the entries are judged primarily on the suitability of the team to provide a pleasant drive. Mules should show cooperation and unity under harness, quality gaits, alert expressions, smooth transitions and good manners. Emphasis is 70% on performance, manners and way of going; 20% n condition and fit of harness and vehicle and 10% on neatness of turnout.*

- 4) **Reinsmanship** \* A pleasure driving class in which entries are judged primarily on the ability and skill of the driver.
- (a) **Class Routine:** Mules will be shown at a Walk and Trot both ways of the arena. At the judge's discretion, an extended (road) trot may be requested.
  - (b) Drivers will be required to execute a reinback. Entries may be asked to halt/stop at any time during the class. The class will be reversed as appropriate for the class size/type of hitch.
  - (c) **Extra Work:** The judge may request each driver to execute Figure 8 or other maneuvers.
  - (d) **Judging Considerations:** Emphasis is 75% on handling of the lines and whip, control, posture and overall turnout of the driver; 25% on the condition and fit of the harness and vehicle.
- 5) **Multiple Hitches Driving** classes highlighting the versatility and tradition of the working mule. Of primary importance is the overall performance of the hitch, which all mules worked collaboratively and effectively. On the reinback, the lead mule(s) should not be "dragged" backwards by the wheel and/or swing teams. Classes may include the Unicorn Hitch, Four Mule Hitch, Six Mule Hitch and Eight Mule Hitch.
- (a) **Class Routine:** Mules will be shown at a Walk and Trot both ways fo the arena.
  - (b) Drivers will be required to reinback. Entries may be asked to halt/stop at any time during the class. The class will be reversed across the diagonal length of the arena.
  - (c) **Judging Considerations:** Mules should show cooperation unity under harness, quality gaits, alert expressions, smooth transitions and good manners. Mules should show an ability to work as a unit with evenness of tugs. Emphasis is 70% on performance, manners and way of going; 20% on condition and fit of harness and vehicle and 10% on neatness of turnout.
- 6) **Obstacle Driving**\* Obstacle driving will be judged on performance of the mule(s) through a prescribed set of obstacles. Overchecks are not allowed and will be cause for disqualification. Entries may attempt an obstacle three times. If the entry is not successful in negotiating the obstacle after three times, the entry must move on to the next obstacle.
- (a) **Class Routine:** Drivers must be allowed to walk the course prior to the start of a class and inspect each obstacle. While walking the course, drivers shall not alter, adjust or in any way move an obstacle or any part thereof. Should a driver have any question regarding a specific obstacle, it should be brought to the attention of the ring steward for clarification. Drivers are prohibited from driving, leading or riding mules or allowing mules to be driven, lead or ridden

- on any portion of the course at any time prior to the competition unless permitted by show management. Noncompliance will result in disqualification. As a part of the competition, the judge may ask drivers to reinback at the completion of the course.*
- (b) *Course Requirements: The course shall include a minimum of six and a maximum of eight obstacles, selected from the list of obstacles. Care must be exercised to avoid setting up any obstacle in a manner that may be hazardous to the mule(s) or driver.*
- (c) *The obstacle course must be outlined by the show management and posted prior to the start of the class for the information of the exhibitors and judge.*
- (d) *The course shall be designed to require each entry to demonstrate the walk and trot somewhere between obstacles as part of the working course with enough space provided for the judge to evaluate the gaits.*
- (e) *Mandatory Obstacles:*
- (1) *Back Through: Consists of either two landscape timbers, poles or pylons set at a minimum of ten feet apart. For Team classes or larger vehicle widths, these should be adjusted accordingly.*
  - (2) *Box or Garage: Three rails, a minimum of 15 feet long are set in a three-sided box. Mules must be driven up to the obstacle, side pass to position the vehicle and then backed into the box until the rear wheels/tires of the vehicle touch the back pole. If rails are elevated, they may not be over 10 inches high.*
  - (3) *Serpentine: A minimum of three pylons around which the mule is driven in a serpentine fashion at a walk (pylons are at least 15 feet apart) or a trot (pylons at least 20 feet apart.) These should be adjusted accordingly for team classes or larger vehicles.*
  - (4) *Straight and narrow: Two parallel poles, one foot apart a minimum of 25 feet long. Driver must keep one wheel (cart) or both wheels (wagon or similar vehicle) between the poles for the entire length. May be taken at the walk or trot. Width between the poles may be adjusted for larger vehicles or vehicles with wide tires.*
- (f) *Optional Obstacles:*
- (1) *Bridge:*
  - (2) *A simulated bridge of a width at least 10 feet. To be taken at the walk only*
  - (3) *Figure 8: Two barrels or pylons around which the entry must make a Figure 8 in a forward motion. Walk obstacles to be a minimum of 10 feet apart. Trot obstacles to be a minimum of 20 feet apart. These should be adjusted accordingly for team classes or larger vehicle widths.*

- (4) *L-Obstacles: Rails placed in an “L” shape at least 15 feet apart through which the mule is driven at a walk only. If the rails are elevated, the maximum height is 10 inches. The side of the “L” may not be less than 20 feet long. Width may be adjusted for teams or larger vehicles.*
- (5) *Mailbox: The mailbox must be set on a stand with a minimum height of four feet. Exhibitor must open the box, remove the “mail”, show it to the judge and then replace the “mail” in the box. Mailbox height may be adjusted for larger vehicles.*
- (6) *Simulated Water: A plastic sheet or tarp secured to the ground so that it will not become entangled or affixed to the mule’s foot or the wheel of the vehicle when it is passed over.*
- (7) *U-Turn: A three rail box of which the rails are a minimum of 25 feet long, with a pylon located in the center of the opening of the box. The driver is to enter the box, drive around the pylon and exit the other side, making a “U”.*
- (g) *Prohibited Obstacles:*
- (1) *Live animals and hides*
  - (2) *Driver dismount*
- (h) *Scoring:*
- (1) *An entry with major faults (knockdowns, refusals, etc.) on the course will not be placed ahead of an entry that worked through the obstacles cleanly.*
  - (2) *Entries should be penalized for touch of any element of the course (unless dictated as a part of the obstacle) and for unnecessary delay in approaching the obstacle.*
  - (3) *Off course*
  - (4) *Deviating from the prescribed order in which the obstacles are to be approached*
  - (5) *Taking the obstacle from the wrong direction*
  - (6) *Negotiating an obstacle from the wrong side*
  - (7) *Skipping an obstacle unless directed by the judge*
  - (8) *Disqualification*
  - (9) *Driver receiving outside assistance*
  - (10) *Breaking into a canter*
  - (11) *Use of an overcheck*
  - (12) *Equipment failure resulting in elimination*
- 7) *Gambler’s Choice A timed driving obstacle course of unnumbered obstacles each carrying a specific point value. Each driver has the same amount of time to negotiate as many of the obstacles as possible. Each obstacle is assigned a point value according to its degree of difficulty*

*and each driver tries to amass as high a score as possible within the time allowed. The course shall include obstacles listed under Obstacle Driving.*

*(a) Class Routine:*

- (1) After passing through the starting line, the driver may drive through the obstacles in any order and from any direction. No obstacle may be driven in succession. No obstacle may be re-driven once it has been disturbed (unless dictated as a part of the obstacle)*
- (2) A 30-second warning to the completion of the of the allowed will be given.*
- (3) The entry must be past the finish line prior to the expiration of the allotted time or the entry will be disqualified and no points accrued.*
- (4) If a disturbed obstacle is re-driven, no points will accrue for that obstacle.*

*(b) Scoring*

- (1) Placings will be determined on high score basis. Time will decide ties. The entry with most points in the shortest time will place over an entry with the same number of points with a longer time on course. If a tie occurs in both points and time, the winner will be decided by a drive-off.*
- (2) No points will be awarded to an incorrectly completed obstacle. If the obstacle is incorrectly driven, but not disturbed, it may be attempted again.*
- (3) In this class the circling rule does not apply. If a mule should refuse or run out of an obstacle without disturbing it, the driver may elect not to attempt it and may drive to another obstacle without penalty. The obstacle may be attempted later, and if correctly driven, the appropriate points would be recorded.*
- (4) Canterng will be a cause for disqualification.*

*8) Log Skidding This is a judged event consisting of a mule/team dragging a log between a series of obstacles. Classes can be established for singles or pairs.*

*(a) Class Routine:*

- (1) Each entry will enter the arena individually.*
- (2) The driver may be assisted in hooking to the log. This may be included as part of the judging. Once hooked, the entry will proceed from the start/finish line and maneuver the course.*
- (3) No outside assistance is allowed.*
- (4) Points are assigned for a smooth, clean, efficient run; the responsiveness and manners of the mule(s) and the driving ability of the driver.*

- (5) *An entry with major faults shall not place above an entry that worked through the obstacles cleanly.*
  - (6) *After maneuvering through the course, the entry will return to the start/finish line and unhook. The driver may be assisted in unhooking.*
  - (b) *Course Set-Up: The course may be determined by the judge and/or show management.*
    - (1) *It should include a serpentine of at least six pylons spaced a minimum of 15 feet apart. If a parallel obstacle is included, the minimum width between the rails should be single/double-tree width plus 16 inches.*
    - (2) *Side lines may be utilized parallel to the line of cones for the serpentine. A minimum of 15 feet should be allowed for any end lines or side lines.*
  - (c) *Show management shall provide:*
    - (1) *Logs proportionate in length and weight to the majority of the animals to be shown. A log 8 foot long and 8 inches in diameter is suggested.*
    - (2) *Chain loop: Each log will be wrapped with a piece of chain to make a loop not to exceed 24 inches to which a single/double-tree can be hooked. The chain should extend from the sides of the log, V-shaped, in such a manner that the log will not turn.*
    - (3) *Single/double-tree(s) with hooks and connector for the log.*
  - (d) *Judging Considerations*
    - (1) *Drivers are allowed to encourage their mules forward with voice commands or slapping of the lines (but not excessively).*
    - (2) *No whips or use of the end of the lines is allowed.*
    - (3) *Driver may drive from either side, changing sides as*
    - (4) *necessary.*
    - (5) *A penalty is assessed each time an obstacle is stepped on or over or disturbed in any way by the animal, the driver or the log. Tennis balls may be placed on top of the pylons to indicate penalties*
    - (6) *Failure to follow the pattern is a disqualification*
- 9) HERITAGE DRIVING/ANTIQUÉ VEHICLE**
- (a) *Class Routine:*
    - (1) *To be shown at the Walk both ways of the arena. Depending on the number/type of entries, the entries may be asked to Trot.*
    - (2) *The class will reverse in a manner at the discretion of the judge, although a diagonal reverse is suggested.*
    - (3) *Entries may be asked to reinback.*
    - (4) *Judging Considerations: To be judged 50% on performance; 20% on apparel*

*of driver and personal appointments;  
15% on vehicle and 15% on harness.*

*(5) Apparel: The required/appropriate costumes should be dated on the vintage of the vehicle.*

*(b) Vehicle: The antique type vehicles should be sound and safe for driving, and the wheels and spokes tight. The mule(s) should be suitable to the vehicle and there should be a pleasing balance between the two.*

*(c) Harness: The harness should be in good repair, clean and fit properly. All metal furnishings should match, be secure and polished.*

**10) PARADE HITCH** *This class highlights the use of the Draft Mule as an appropriate harness animal for parades. All entries should be in good taste and promote crowd appeal. Manners are of utmost importance. Entries may be asked to Halt/Stop multiple times during the class, simulating participation in a parade.*

*(a) Class Routine:*

*(1) To be shown at the Walk both ways of the arena. The class should reverse along the diagonal length of the arena at the direction of the ring steward. Entries may be asked to halt/stop multiple times.*

*(b) Judging Considerations:*

*(1) To be judged 50% on performance, attentiveness and manners; 20% on apparel of driver/assistants and personal appointments; 15% on vehicle and harness and 15% on overall balance and appearance.*

*(2) When asked to Halt/Stop, the mule(s) should stand quietly and calmly, ready to respond to the direction of the driver immediately.*

**11) Farm Team Race** *This class simulates the use of Draft Mules for farm/ranch work. It is a timed and judged event. In addition to the driver, an assistant or swamper is allowed.*

*(a) Class Routine:*

*(1) The entries may compete individually or two at a time, with identical courses set up side-by-side. The driver will be on a forecart. Hooking to the sled may be part of the competition or may be done prior to the entry crossing the start/finish line.*

*(2) On a signal, the entry will cross the start/finish line. the driver must followed the prescribed course or pattern. The swamper must remain on the sled until it comes to a complete stop.*

*(3) The driver will proceed to the first obstacle. The swamper will negotiate the obstacle. This many include:*

*(4) Opening a gate, allowing the driver and sled to pass through, then closing the gate*

*(5) Loading objects from a pallet to the sled*

- (6) *Unload objects from the sled to a pallet*
- (7) *Hooking/unhooking the sled to the forecart*
- (8) *Once the course is completed, the driver must cross back across the start/finish line.*
- (9) *Time begins and ends when the neck yoke of the team passes the start/finish line. The course shall be determined at the discretion of the judge and/or show management.*
- (10) *A copy of the course and rules for the class shall be posted prior to the start of the class.*
- (11) *Drivers and swampers may walk the course as a group prior to the start of the class. No animals are allowed on the course prior to the start of competition. When walking the course, drivers and swampers are not to alter, change or otherwise disturb the course.*

**(b) Judging Considerations:**

- (1) *The fastest overall time wins. Raw time on the course may be modified by time penalties assessed per occurrence.*
  - (2) *If equipment provided by show management fails and the run cannot be completed, the exhibitor will be granted a re-run.*
  - (3) *Each time there is a cantering occurrence of more than three strides by either mule, a 30 second penalty is added to the raw time.*
  - (4) *Each time an object is not placed completely on the pallet, a 10 second penalty is added to the raw time.*
  - (5) *If the swamper departs the sled before it comes to a full stop, a 30 second penalty is added to the raw time. If the swamper is not on the sled before it departs from a full stop, a 30 second penalty is added to the raw time.*
  - (6) *If an object is broken, damaged or otherwise unusable a 30 second penalty is added to the raw time.*
  - (7) *If the driver, swamper or an object falls off, a 30 second penalty is added to the raw time.*
  - (8) *If pylons, pallets or other set portions of the course are disturbed, a 15 second penalty is added to the raw time. If the driver goes off course, the entry is disqualified.*
- 12) **Farm Team Driving** *This class is designed to highlight the everyday work use of Draft Mules. Any type of working farm equipment, including two or four wheeled wagons are allowed. Vehicles may have wood wheels, steel wheels or rubber tires. Vehicles may also include home-built or training type equipment. Emphasis is on working tack and equipment. No Buxton*

*bits, show harness, scotch top collars or 5th wheel wagons are allowed.*

*(a) Class Routine:*

- (1) To be shown at the Walk both ways of the arena.*
- (2) Entries may be asked to Trot at the judge's discretion if appropriate for entries. Entries may be asked to reinback.*
- (3) Depending on class size and types of equipment, the preferred reverse will be done along the diagonal length of the arena.*
- (4) At the judge's discretion, individual work may be requested which might be required while working with the specific equipment, such as swinging the team to one or both sides or engaging the equipment.*
- (5) Equipment to be used in the class must be cleared through show management prior to the start of class for safety and arena condition considerations.*
- (6) Appropriate attire suitable to the vehicle/equipment is encouraged.*

*(b) Judging Considerations:*

- (1) Should stand quietly and, for team entries, show an ability to work as a unit with evenness of tugs.*
- (2) To be judged on performance and handiness and suitability of the mule(s) to pull and work the specific vehicle/equipment, with an emphasis on responsiveness to driver and manners*

# INDEX

Patterns & Illustrations can be found with the classes.

---

## 3

30 Second Warning · 119

---

## A

Abuse · 125, 146

Age

Animal · 53

Amateur · 70

Discipline · 72

Eligibility · 71

Membership · 70

Novice Amateur Eligibility · 72

Remuneration · 71

Amendment · 17

American Horse Show Association · 148

Association

Funds · 28

Liability · 27, 28

Responsibility · 24, 27

Awards

NASMA Amateur Champion Mule · 42

NASMA Champion Mule/Donkey · 41

NASMA Performance Versatility · 42

NASMA Superior Event Mule/Donkey · 41

NASMA Youth Champion Mule · 41

Year End High Point · 42

---

## B

Bits · 74, 82, 89, 132, 148

*Board of Directors* · 9, 10, 11, 13, 14, 15, 16, 17, 18, 19,  
20, 21, 22, 23, 24, 25, 28, 29, 30, 31, 32, 33, 34, 53, 140

By Laws

Amendments · 17

Parliamentary Procedure · 18

---

## C

Canada · 12, 32

Cattle Classes

Buffalo Hunt · 122

Calf Roping · 36, 42, 121

Cutting · 35, 36, 42, 122

General Roping Rules · 120  
Steer Stopping (Judged) · 122  
Team Penning · 36, 37, 42, 55, 118  
Team Roping (Judged) · 121  
Working Cow Mule · 35, 36, 42, 55, 113  
**Cattle Numbers** · 119  
Changing Hands on Reins · 90, 93, 108  
Chaps · 89, 120, 131  
Class Divisions · 58  
    Donkey Training Level · 59  
    Green Mules · 39, 58  
    JR Mules · 34, 39, 55, 58, 77, 93, 97, 99, 108, 147  
    SR Mules · 34, 39, 58, 133  
Class Routine · 76, 77, 82, 83, 85, 86, 87, 91, 92, 99, 105,  
    141, 144, 148  
Complaint · 30, 49  
Coon Jump · 40, 89, 145  
Corporate Seal · 10  
**Course Requirements** · 79, 84  
Cow Work · 113, 114  
Curb · 58, 89, 90, 105, 139  
Curb Bits · 89  
**Curb Chains** · 89

---

## **D**

Directors  
    Authority · 14  
    Directors-At-Large: · 13  
    Election · 11  
        Alternate · 13  
        Election Results · 13  
    Liability · 14  
    Meetings  
        Special · 14  
    Nominating  
        Nominating Committee · 12, 13, 15, 16  
        Nominations From Regional Clubs · 12  
        Nominations From The Floor · 13  
    Terms · 11  
Disciplinary Action · 14, 15, 23, 24, 27, 28, 30, 31, 43, 47,  
    48, 49, 52, 53, 58, 71, 72, 134, 140, 141  
Expulsion · 29  
Grievance Committee · 29, 53  
Protest · 30, 54  
Protests  
    Documentation · 29  
    Hearing · 30  
    Testimony · 30  
**Disobediencies** · 78, 80  
**Disqualification** · 85, 93, 97, 99, 100, 120  
Donkey · 5, 32, 34, 35, 37, 38, 39, 40, 41, 42, 43, 56, 57,  
    58, 59, 87  
Donkey General Rules · 56  
    Jack Halters · 56  
    Jackstock · 56

Side Saddle · 56  
Youth Showing Jacks · 56  
Donkey Training Level · 59  
Donkeymanship · 37, 59, 105, 141, 144  
DQP · 44, 133, 141  
*DRAFT DIVISION* · 149  
Driving  
Attire · 81  
Bits · 82  
Cantering · 82  
Concourse D'Elegance · 87  
Course Time · 82  
Double Jeopardy · 36, 85  
DRIVING TERMINOLOGY and Gaits · 80  
Excessive Use of Voice · 82  
Gamblers Choice · 85  
Harness · 81, 86  
Heritage Driving/Antique Vehicle · 36, 86  
Leaving Arena · 82  
Obstacle Driving · 36, 37, 42, 55, 83  
Outside Assistance · 81  
Pleasure Driving - Turnout · 83  
Pleasure Driving – Working · 82  
Reinsmanship · 36, 37, 42, 83  
Snigging (Log Dragging) · 87  
Splitting Classes · 82  
Suitability of Animal · 81  
Turnout · 82  
Whip · 81, 132  
Driving Rules · 80  
Driving: · 36

---

## *E*

Elimination · 78, 80, 85, 148  
English · 74  
Attire · 74  
English Pleasure · 35, 36, 76  
Hunter Hack · 35, 36, 37, 40, 42, 77  
Hunter Under Saddle · 35, 36, 40, 42, 69, 76, 77  
Jumping · 35, 36, 40, 55, 78, 79, 80, 146  
Legal Bits · 74  
Optional Equipment · 74  
Tack · 74  
Terminology & Gaits · 75  
Working Hunter · 35, 36, 40, 42, 55, 77  
Equitation · 141  
Executive Committee  
Advisors · 15  
Meetings · 15  
Recall · 18  
Responsibility · 16  
Exhibitors  
Judges Card Changes · 51  
Judges Decision · 51

---

## **F**

Faults · 76, 77, 80, 85, 92, 93, 100, 114

---

## **G**

Gaited · 131

Attire · 131

Classes

English Pleasure · 135, 136

English Trail Pleasure · 136

General Rules · 133

Abusive Treatment · 133

Age Determination · 133

Age Divisions · 133

Show Approval · 133

Time Outs · 139

Halter · 137

Mulemanship/Saddle Seat Equitation · 136

Racking Mule Division

Racking Mule Class · 136

Speed Racking · 135

Style Racking · 135

Rider Divisions

Amateur · 140

Open · 140

Rider Falls · 140

Trail Obstacle · 136

Unruly Mules · 140

Walking Mule Division · 135

Western Trail Pleasure · 136

Workouts · 140

Gaits · 135

Other Gaited Mules · 135, 136

Racking Mules

Show Walk · 134

Slow Rack · 134

Style Rack · 135

Walking Mules

Canter · 134

Flat Walk · 134

Running Walk · 134

Grievances and Protest · 140

Shoeing · 132

Barefoot · 132

Heavy Shod · 133

Light Shod · 133

Pads · 133

Plantation Shoe · 133

Show Mules · 133

Tack

Fine Harness · 82, 132

Under Saddle

Bits

9½ Shank: · 131

- Mouthpieces · 131
- Standard Walking Horse Bit · 131
- Bridles · 132
- Whips
  - English · 132
  - Western · 132
- General Show Rules · 54
  - Announcing Entries · 55
  - Cancellations · 33, 54
  - Eligible Animals · 54
  - Entry Errors · 54
  - Entry Fees · 54
  - Gate Call · 54
  - Numbers · 54
  - Show Start Time · 54
  - Single Entry · 55
  - Splitting Classes · 54
  - Withdrawing · 55
- Green Mule · 59
- Grievance · 18, 20, 24, 29, 30, 31, 53, 54, 140, 141
  - Board Of Directors Involvement · 30
  - Filing Protests
    - Chairman Of The Grievance Committee · 30
    - Process · 30
  - Filing Protests: · 30
- Grievance Committee
  - Officer Recall · 18
- Gymkhana · 56, 89, 131
  - Animal Abuse · 121, 125
  - Attire
    - Hat · 124
  - Barrel Racing · 126
  - Flag Race · 130
  - Gate · 125
  - Hurdle Race · 129
  - Keyhole · 127, 129
  - Pole Bending · 125
  - Pylon Alley · 128
  - Rules · 124
  - Starting Line · 124
  - Time Limit · 125
  - Timer · 124

---

## ***H***

- Hackamore · 124
- Hackamores** · 89
- Halter Rules · 57
  - Class Divisions · 57
  - Class Routine · 57
  - Examination · 57
  - Grand & Reserve Champions · 58
- Hat · 50, 81, 86, 89, 124, 131, 145, 148
- Hobbles · 90

---

## *I*

### Inhumane Treatment

- Bits · 44
- Blood Letting · 44
- Soring · 44
- Tying · 44

---

## *J*

### Judges

- Attire · 50
  - Conduct · 50
  - Conflict Of Interest: · 50
  - Decisions
    - Cards · 51
    - Final · 51
  - Formal Complaint Against · 49
  - Guest Judge Card · 49
  - Gymkhana Disqualifying · 125
  - Halter Examination · 57
  - Qualifications: · 49
  - Responsibility
    - Arrival At Show · 50
    - Equipment Check** · 51
    - Lameness Check · 51
  - Review · 49
  - Splitting Classes · 82
  - Treatment
    - Working Hours · 51
- Judging Considerations · 76, 77, 78, 82, 83, 85, 86, 87, 91, 92, 97, 99, 108, 134, 144, 147, 148
- Junior Mules · 58

---

## *L*

- Lameness: · 51

---

## *M*

- Mandatory · 84, 109, 137
- Martingales · 82, 90, 132
- Membership
  - Application · 25
  - Categories
    - Amateur Membership · 25
    - Annual Membership · 17, 25
    - Charter Membership · 25, 26
    - Family Membership · 25
    - Lifetime Membership · 25, 26
    - Ten Year Membership · 25, 26
- Denial Of Privileges · 29

Fraud · 29  
Meetings  
    Acting Chairman · 11  
    Annual Meeting · 10, 11, 13, 14, 15, 16, 17, 19, 22  
    Proxy · 11  
    Special Meetings · 11, 14  
Members · 10, 11, 14, 24, 25  
Responsibility · 28  
Voting · 10  
Membership: · 3, 9, 16, 17, 24, 25, 26, 48  
**MOUTHING CERTIFICATE** · 171  
Mulemanship · 141

---

## **N**

NASMA Youth · 9  
NCHA · 122  
Nonmember · 25, 28, 29, 31, 32, 40  
Notice Procedure  
    General · 32  
Novice Youth · 69

---

## **O**

Obstacle · 36, 37, 42, 55, 83, 136  
Off Course · 78, 85  
Officers & Board Members · 2  
Officers And Duties  
    Officers  
        Executive Secretary · 10, 11, 14, 15, 16, 17, 44, 48, 74  
        President Elect · 13, 15, 16, 17  
        Treasurer · 16, 17, 18, 23  
        Vice President · 11, 16  
Officers: · 11, 12, 13, 14, 15, 16, 17, 18, 19, 20, 22, 26,  
    30, 73  
Recall · 20  
Vacancies · 17  
Written Contracts · 17

---

## **P**

Pattern · 92, 97, 98, 99, 105, 108  
Performance Rules  
    Arena Gates · 56  
    Cross Entries · 55  
    Entries Per Exhibitor · 55  
    Equipment · 48, 50, 51, 55, 58, 79, 80, 82, 85, 90, 91, 99,  
    109, 120, 121, 122, 131, 139, 148  
    Go-Rounds · 56  
    Ground Conditions · 56  
    Reverse · 56  
    Splitting Classes · 82  
Points · 38, 39, 41, 42, 72, 73, 83, 108, 120, 121

Tabulation  
Registration Requirements · 38  
Port · 74, 89, 131, 132  
Premium Lists · 38  
Prohibited · 75, 84, 90, 110, 131, 137  
Prohibited Substance · See Drugs  
Protest · 29, 30, 53, 54, 73, 133, 140, 141

---

## **R**

Regional Club · 22  
Regional Clubs · 23, 24  
Reining · 99  
Reruns · 55, 120, 121  
Rider/Exhibitor Divisions · 69  
Amateur · 26, 42, 70, 72, 140  
Novice Youth · 39, 69, 73  
Open · 34, 38, 39, 55, 59, 69, 72, 77, 115, 135, 140, 148  
Ten & Under · 69  
Youth · 9, 10, 20, 24, 25, 34, 36, 37, 38, 39, 40, 41, 42,  
54, 56, 59, 69, 70, 71, 72, 74, 77, 79, 98, 108, 135, 140  
Ring Steward · 52  
Romal · 89, 92, 99, 100, 113, 114, 115, 120, 132, 145  
Rule Book Change · 20, 21, 22

---

## **S**

Scoring · 78, 80, 84, 86, 93, 97, 99, 113, 120, 141  
Senior Mules · 58  
**Shanks** · 89, 131  
Show  
Eligibility  
Animal Age · 53  
Show Approval  
Application · 32  
Points · 38  
Requirements  
Cancellations: · 33, 54  
Judges  
Multiple Judge Shows · 37  
Single Judged Shows · 37  
Mileage Between Shows: · 32  
Permission For Use Of NASMA Titles · 33  
Show Results · 33  
Show Protest · 20, 53  
Procedures · 53  
See 101 Standing Committees, 11. · 53  
Violations Not Addressed by Grievance Committee · 53,  
140  
Show results · 33  
Showmanship · 141  
Appearance of the Exhibitor · 142  
Fitting of the Animal · 141  
Judging · 141

- Leading & Posing the Animal · 142
- Quality of Performance · 143
- Quarter Method · 143
- Shows
  - Class Divisions · 58
  - Personnel
    - Veterinarian · 53
  - Requirements
    - High Point Divisions · 39
    - Placings · 39
  - Rider/Exhibitor Divisions · 69
- Snaffle · 82, 132
- Snigging · 37, 87
- Specialty Classes · 36, 145
  - Costume · 146
  - Dressage · 35, 36, 37, 40, 42, 50, 148
  - Freestyle Reining · 36, 40, 146, 148
  - Ladies Side Saddle · 148
- Spurs · 74, 89, 90
- Standing Committees
  - Budgets · 19
  - Committee
    - Awards Committee · 20
    - By Laws Committee · 20
    - General Show And Contest Rules Committee · 19, 21
    - Grievance Committee · 18, 20, 25, 29, 30, 31, 53, 140, 141
    - Scholarship Committee · 20
    - Show And Contest Sanctioning Committee · 20
    - Special Committees · 20
    - World Show Committee · 20
    - Youth Committee · 20
  - Meeting Quorum · 19, 30
  - Meetings · 19
- Standing Committees: · 19
- Surgical Procedures
  - Banned · 44
- Suspension · 14, 27, 28, 49, 53, 71, 141

---

## ***T***

- Tapaderos · 90
- Ten and Under · 69
- The Quarter Method** · 143
- Tie-downs · 90
- Timer · 53, 124, 127, 128, 130, 141

---

## ***U***

- USTPA · 118

---

## V

Versatility Trail Program · 8

Veterinarian · 53

---

## W

Western · 89

Attire · 89, 124

Bits · 89

    Curb Chains · 89

    Mouthpieces · 89

    Port · 89

    Shanks · 89

Hackamore · 89

Ranch Riding · 35, 36, 37, 40, 42, 97

Reined Working Donkey · 37, 105

Reining · 35, 36, 40, 42, 55, 90, 97, 99, 146, 148

Reins

    Changing Hands · 90, 93, 108

    Romal · 89

Snaffles · 89

Tack

    Hobbles · 90

    Prohibited

        Bits · 90

        Martingales · 90

        Nosebands · 90

        Protective Boots · 90

        tiedowns · 90

        Wire Chin Straps · 90

    Riata · 90

    Saddle · 90

Tapaderos · 90

Trail · 8, 20, 24, 35, 36, 37, 40, 42, 55, 59, 69, 97, 108,  
110, 136, 137

    Changing Hands on Reins · 108

    Optional Obstacles · 109

    Pattern Specifics · 97, 108

    Posting Pattern · 108

    Prohibited Obstacles · 110, 137

    Required Obstacles · 109

Western Pleasure · 35, 36, 40, 41, 42, 55, 69, 91

Western Riding · 35, 36, 40, 42, 55, 92, 97

Western Terminology and Gaits · 91

Western Pleasure · 91

Whip · 81, 83, 85, 86, 99, 125, 132, 148

# VETERINARIAN MOUTHING CERTIFICATE OF JUNIOR MULE AGE

- ▶ To be written on veterinarian's stationary
- ▶ A copy must be sent to show management with entry at ever show if animal is not registered with NASMA.
- ▶ A copy must be sent to NASMA office as permanent record.

I, \_\_\_\_\_

*do, hereby, verify that I mouthed the mule*

---

*owned by* \_\_\_\_\_

*on the* \_\_\_\_\_ *day of* \_\_\_\_\_ *20* \_\_\_\_\_

*Based on my examination on this date, the above  
named mule is mouthed as a* \_\_\_\_\_ *year old.*

*And qualifies as a Junior Mule.*

*According to the NAMA rule book requirements,  
this mule will no longer be eligible for Junior Mule  
classes on January 1, 20* \_\_\_\_\_.

---

*Signature of Licensed Veterinarian*

*State:* \_\_\_\_\_



**56695 Ginny Belle Lane  
New London, MO 63459**